

Fusion 700

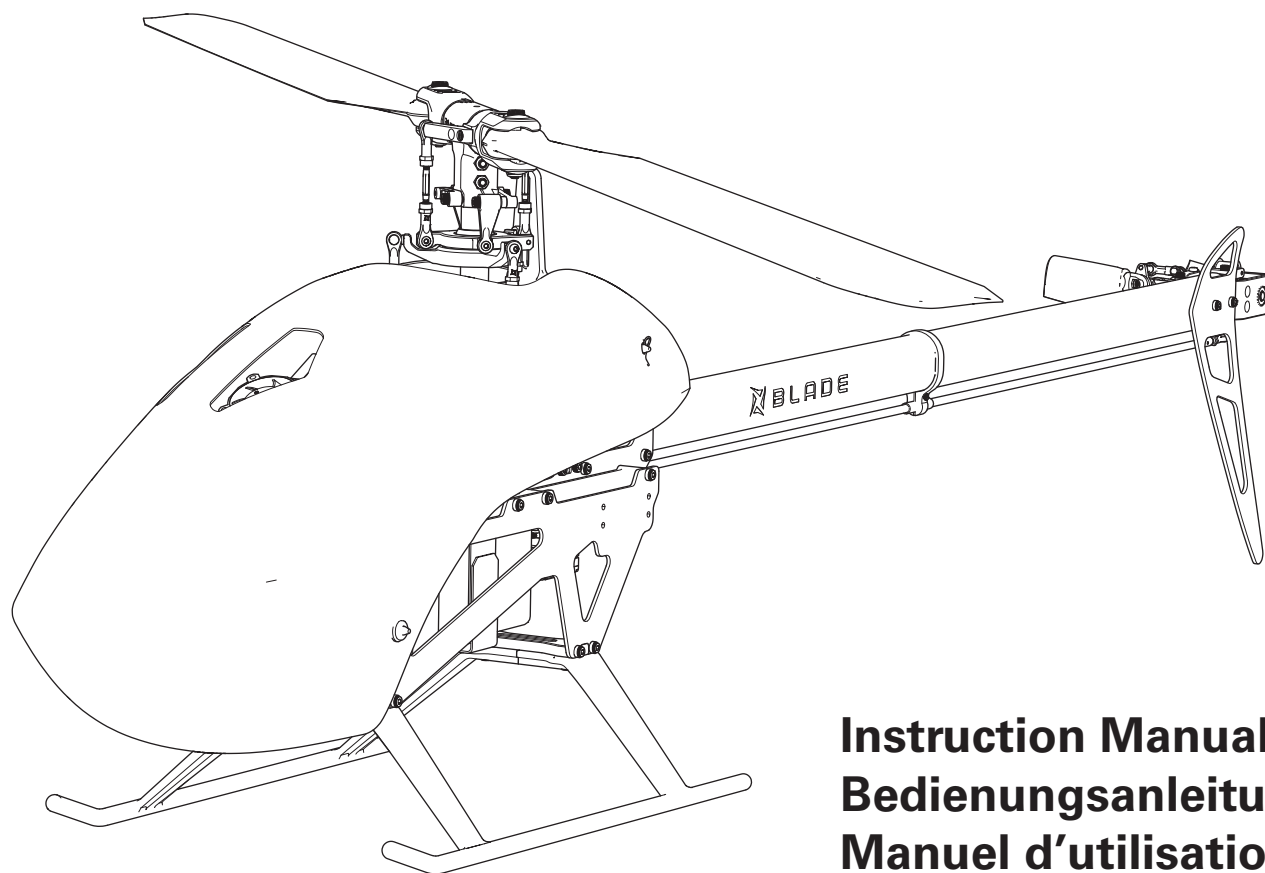

Instruction Manual Bedienungsanleitung Manuel d'utilisation Manuale di Istruzioni

Scan the QR code and select the Manuals and Support quick links from the product page for the most up-to-date manual information.

Scannen Sie den QR-Code und wählen Sie auf der Produktseite die Quicklinks Handbücher und Unterstützung, um die aktuellsten Informationen zu Handbücher.

Scannez le code QR et sélectionnez les liens rapides Manuals and Support sur la page du produit pour obtenir les informations les plus récentes sur le manuel.

Scannerizzare il codice QR e selezionare i Link veloci Manuali e Supporto dalla pagina del prodotto per le informazioni manuali più aggiornate.



NOTICE

All instructions, warranties and other collateral documents are subject to change at the sole discretion of Horizon Hobby, LLC. For up-to-date product literature, visit horizonhobby.com and click on the support tab for this product.

Meaning of Special Language

The following terms are used throughout the product literature to indicate various levels of potential harm when operating this product:

WARNING: Procedures, which if not properly followed, create the probability of property damage, collateral damage, and serious injury OR create a high probability of superficial injury.

CAUTION: Procedures, which if not properly followed, create the probability of physical property damage AND a possibility of serious injury.

NOTICE: Procedures, which if not properly followed, create a possibility of physical property damage AND a little or no possibility of injury.

 **WARNING:** Read the ENTIRE instruction manual to become familiar with the features of the product before operating. Failure to operate the product correctly can result in damage to the product, personal property and cause serious injury.

This is a sophisticated hobby product. It must be operated with caution and common sense and requires some basic mechanical ability. Failure to operate this Product in a safe and responsible manner could result in injury or damage to the product or other property. This product is not intended for use by children without direct adult supervision. Do not use with incompatible components or alter this product in any way outside of the instructions provided by Horizon Hobby, LLC. This manual contains instructions for safety, operation and maintenance. It is essential to read and follow all the instructions and warnings in the manual, prior to assembly, setup or use, in order to operate correctly and avoid damage or serious injury.

Age Recommendation: Not for children under 14 years. This is not a toy.

Safety Precautions and Warnings

- Always keep a safe distance in all directions around your model to avoid collisions or injury. This model is controlled by a radio signal subject to interference from many sources outside your control. Interference can cause momentary loss of control.
- Always operate your model in open spaces away from full-size vehicles, traffic and people.
- Always carefully follow the directions and warnings for this and any optional support equipment (chargers, rechargeable battery packs, etc.).
- Always keep all chemicals, small parts and anything electrical out of the reach of children.
- Always avoid water exposure to all equipment not specifically designed and protected for this purpose. Moisture causes damage to electronics.
- Never place any portion of the model in your mouth as it could cause serious injury or even death.
- Never operate your model with low transmitter batteries.
- Always keep aircraft in sight and under control.
- Always activate throttle hold at rotor strike.
- Always use fully charged batteries.
- Always keep transmitter powered on while aircraft is powered.
- Always remove batteries before disassembly.
- Always keep moving parts clean.
- Always keep parts dry.
- Always let parts cool after use before touching.
- Always remove batteries after use.
- Never operate aircraft with damaged wiring.
- Never touch moving parts.

 **WARNING:** This is a large model helicopter with carbon fiber blades that spin at very high RPM. Always use extreme caution and common sense when maintaining and operating this product. If you are unsure about ANY function or procedure described in this manual, DO NOT operate. Contact Horizon Product Support for assistance.

 **WARNING:** Always ensure you are operating the helicopter a safe distance, 45 feet (13 meters), away from yourself and others.



Table of Contents

| | | | | | |
|---|----|--|----|--|----|
| Safety Precautions and Warnings | 2 | Main Rotor (Bag H)..... | 11 | Postflight Checklist | 24 |
| Table of Contents | 3 | Tail Assembly (Bags B, M, T) | 12 | Blade Tracking | 24 |
| Components Needed to Complete | 3 | Flight Controller Mounting Plate | 16 | Post-Flight Inspection and Maintenance | 25 |
| Assembly Guide Legend..... | 3 | Main and Remote Receiver Mounting..... | 16 | Troubleshooting Guide | 26 |
| Tools Needed To Complete | 3 | Battery Installation..... | 17 | Limited Warranty | 26 |
| Motor and Pinion Assembly (Bag M)..... | 4 | Throttle Hold..... | 17 | Important Federal Aviation Administration (FAA) Infor- mation | 27 |
| Belt Guide and Bearing Block (Bag M)..... | 4 | Setup for FC6350HX Flight Controller | 17 | Warranty and Service Contact Information | 27 |
| Frame Bolt Locations | 5 | Control Tests..... | 21 | FCC Compliance Information..... | 28 |
| Upper Frame (Bags M, H, T) | 6 | Tail Rotor Blade Installation | 22 | IC Compliance Information | 28 |
| Upper Frame (Bags M, H, T) | 7 | Main Rotor Blade Installation | 22 | Compliance Information for the European Union...28 | |
| Servo Setup (Bag A,M)..... | 7 | Canopy Installation | 22 | Exploded View | 31 |
| Servo Mounting (Bag A, M)..... | 8 | Settings for Avian ESC | 23 | Parts List | 32 |
| Landing Gear (Bag M) | 9 | Flight Guidelines and Warnings | 24 | Recommended Components raccomandati | 34 |
| Main Gear Installation (Bag M) | 10 | Flying Your Fusion 700..... | 24 | Optional..... | 34 |
| Install ESC | 11 | Preflight Checklist..... | 24 | | |

Specifications

| | |
|----------------------------|----------------|
| Length | 54.5" (1384mm) |
| Main Rotor Diameter | 62" (1576mm) |
| Tail Rotor Diameter | 11.5" (292mm) |





Components Needed to Complete

| Recommended Component | | BLH13075 Kit Only | BLH13075C Kit + Combo | BLH13075HPC Kit + Combo |
|--------------------------|--|----------------------|--------------------------|----------------------------|
| Motor | Brushless Motor 4735-540Kv (SPMX-1079) | Included | Included | Included |
| ESC | Avian 120HV ESC (SPMXAE1120HV) | Required | Included | |
| | Avian 200A ESC (SPMXAE1200HV) | | | Included |
| Battery | 5000mAh 6S 22.2v X2 100C Smart LiPo Battery: Dual IC5 (SPMX-1091) | Required | Required | Required |
| Flight Controller | FC6350HX Helicopter Flybarless System (SPMFC6350HX) | Required | Included | Included |
| Receiver | DSMX Remote Receiver (SPM9745) | Required | Included | Included |
| Swash Servos | H6350 Digital Brushless Ultra Torque, High Speed Cyclic Servo (SPMSH6350), <i>metal geared servos required</i> | Required | Included | Included |
| Tail Servo | H6360 Digital Brushless Mid Torque / Ultra Speed Heli Tail Servo (SPMSH6360), <i>metal geared servo required</i> | Required | Included | Included |
| Charger | Smart S2200 G2 AC Charger, 2x200 (SPMXC2010) | Required | Required | Required |
| Transmitter | DSM2®/DSMX® Compatible Transmitter | Required | Required | Required |

Tools Needed To Complete

- Medium strength thread-locking compound (Zap Z42 Thread Lock PAAPT42)
- 1.5mm, 2mm, 2.5mm, 3mm and 4mm hex drivers
- Needle nose pliers
- Digital pitch gauge
- Metric ruler or calipers
- Double-sided servo tape
- Servo tester (Spektrum Smart LiPo battery checker & servo driver SPMXBC100)
- (Optional) USB interface programming cable for FC6350HX Flybarless Controller SPMA3065
- (Optional) ESC programming box SPMXCA200

Assembly Guide Legend

| | | | |
|---|--------------------------------------|---|-----------------|
|  | Apply Medium Thread-locking Compound |  | Loosely Tighten |
|  | Apply Medium Cyanoacrylate (CA) |  | Fully Tighten |
|  | Apply NO Thread-locking Compound | | |

To receive product updates, special offers and more, register your product at www.horizonhobby.com

Motor and Pinion Assembly (Bag M)

Bag M5

1. Loosely thread the M4 x 10mm motor mounting screws into place.
2. Select the pinion you want to use. Slide the pinion into place so the pinion helps align the motor on the mount.
3. Tighten the four M4 motor mounting screws.
4. Attach the pinion gear to the motor shaft using thread lock. Be sure to tighten one of the M3 x 4mm set screws on the flat spot of the motor shaft.
5. Attach the bearing support plate and bearing block using M3 x 8mm.

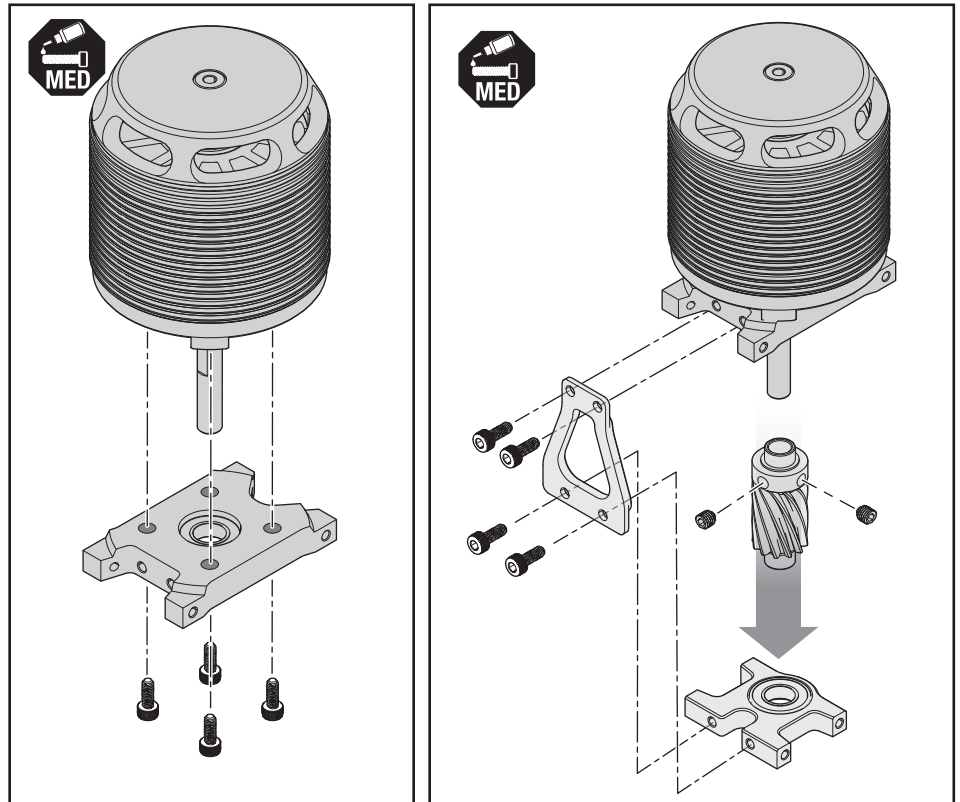

Belt Guide and Bearing Block (Bag M)

Bag M3, M4

1. Attach the anti-rotation guide to the top bearing block support with M3 x 8mm screws.

IMPORTANT: Note the orientation of the bearing block, the top of the bearing block should be flush with the top bearing block support.

2. Attach the top and bottom bearing block support to the bearing block with M3 x 8mm screws.

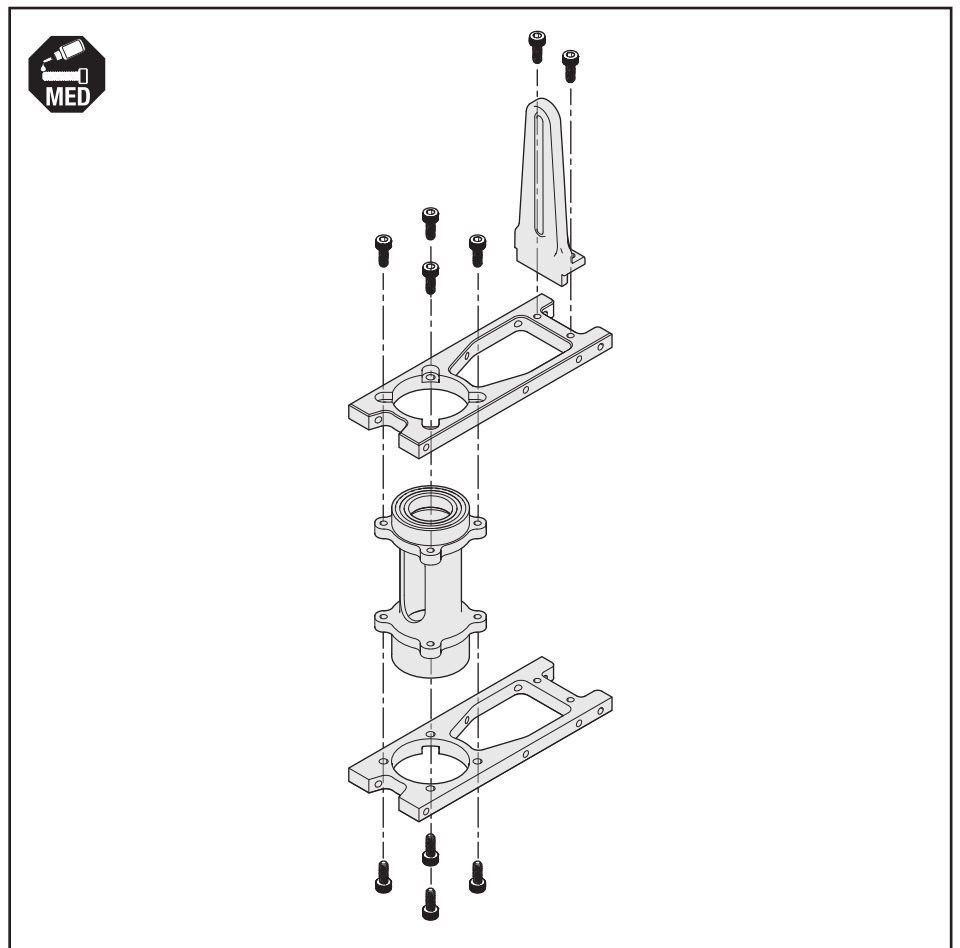

Frame Bolt Locations

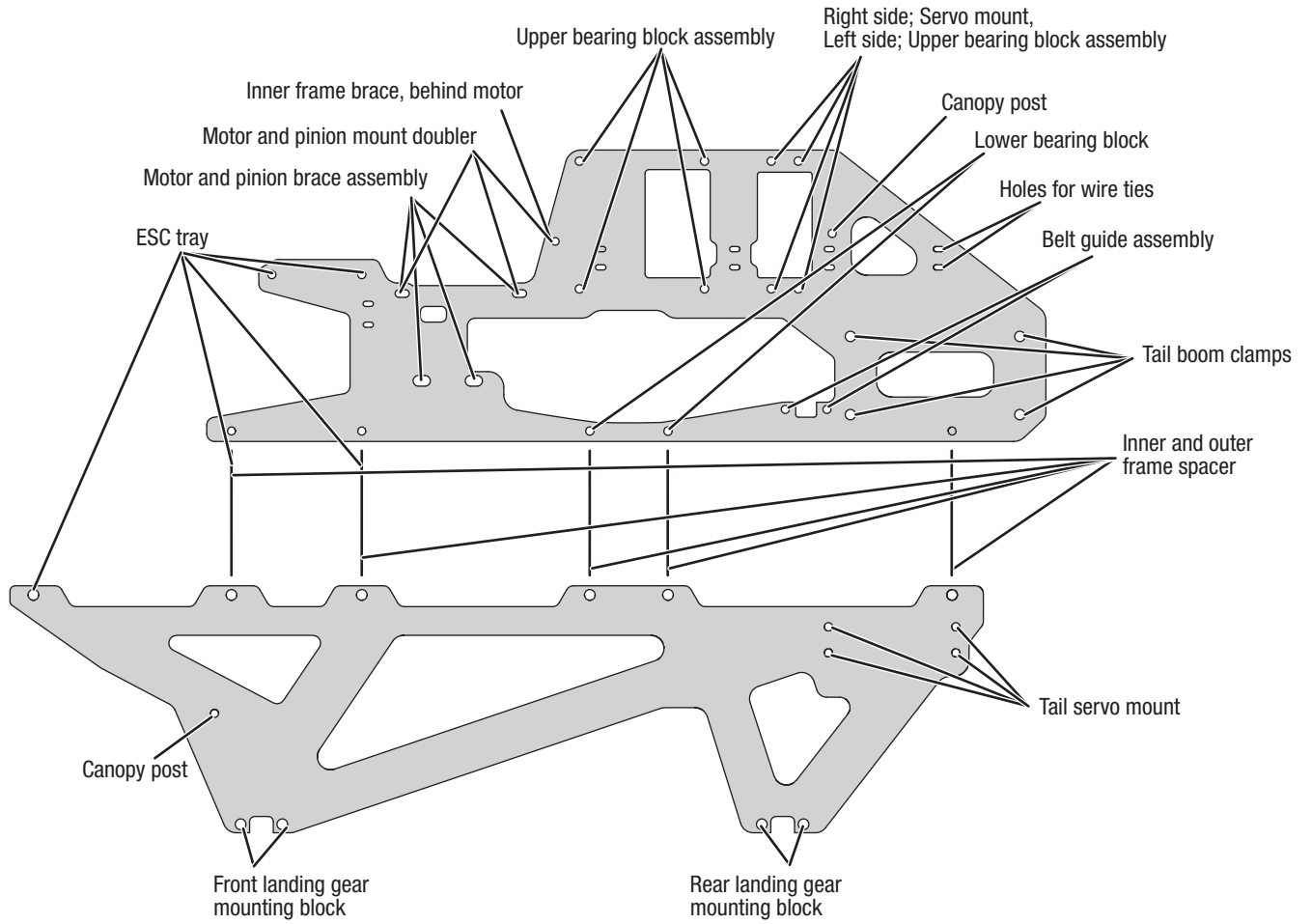

Upper Frame (Bags M, H, T)

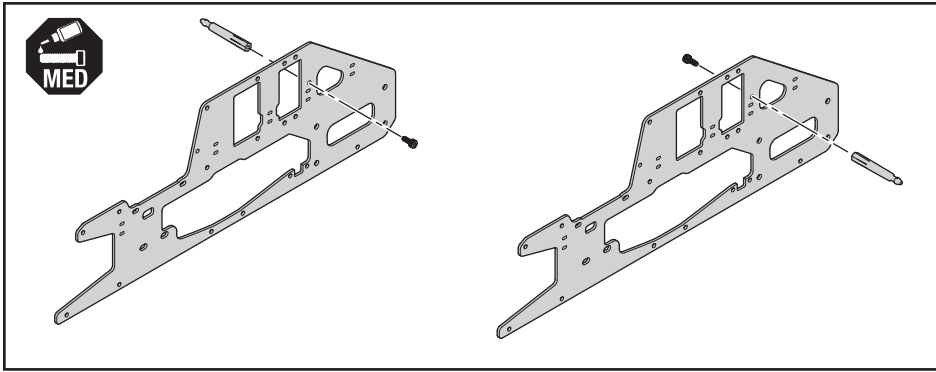

Bag M2, M7, M8

1. Install the rear canopy mounts with an M3 x 8mm screw to the left and right side of the upper frame panels. The rear canopy posts is longer than the front.
2. The M3x14 screws for mounting the rear swashplate servo are dry threaded into the bearing blocks, take them out and save for servo mounting.
3. Loosely install the M3 x 12mm screws to mount the front servo mounts to the upper frame and upper bearing block assembly.
4. Loosely install the four M3 x 6mm screws opposite the rear swashplate servo.
5. Loosely install the M3 x 8mm screws with frame washers to mount the tail boom clamps.
6. Loosely install the M3 x 8mm screws to mount the belt guide assembly.
7. Set the frame sides upright on a flat surface, with the bottom of both sides fully in contact with the work surface.
8. Fully tighten all of the mounting screws.

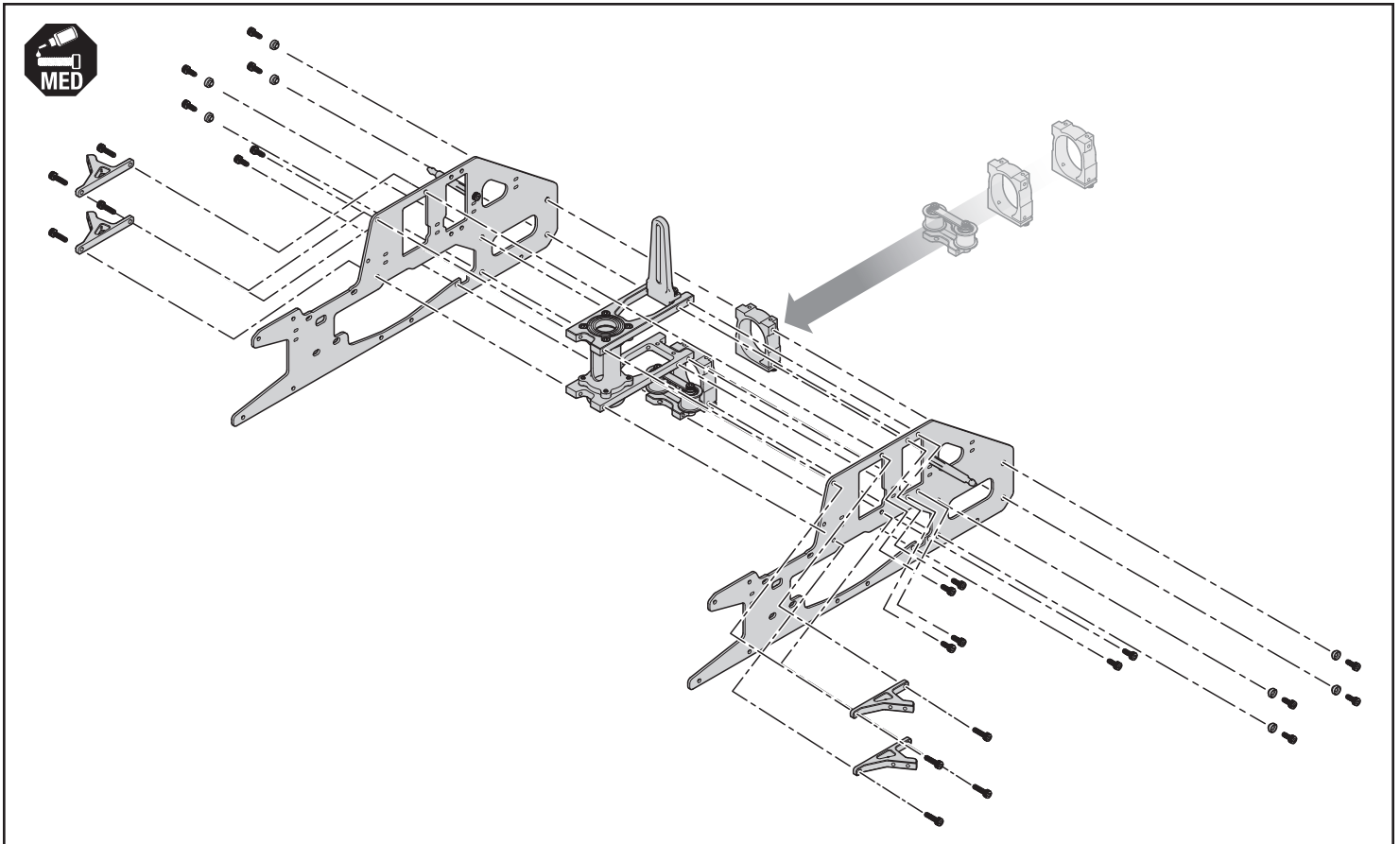

Upper Frame (Bags M, H, T)

Bag M1, M2

1. Install the frame braces into the ESC tray.
2. Install the motor mount assembly, ESC tray, and frame brace behind the motor.

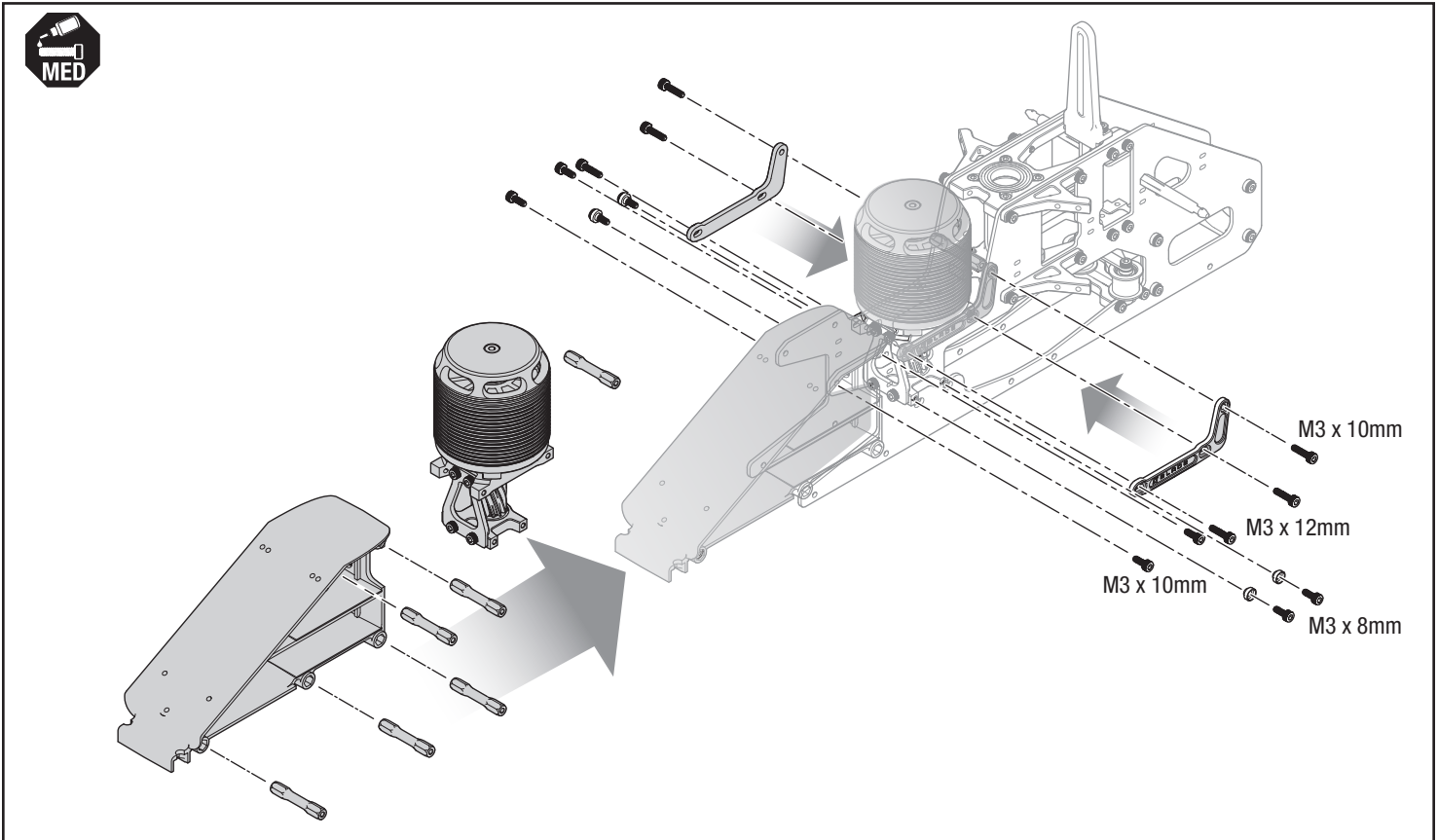

Servo Setup (Bag A,M)

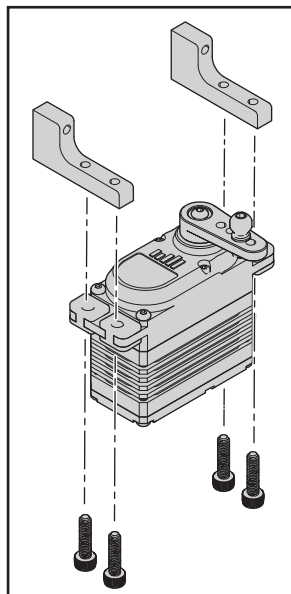
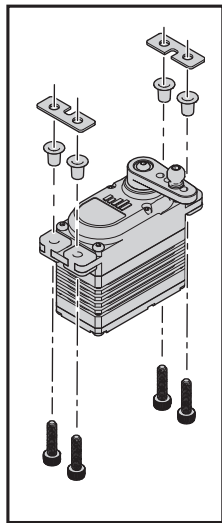
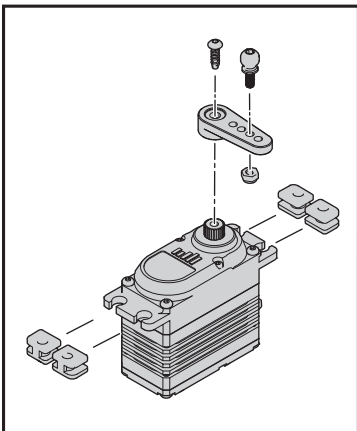

Bag A2, M9

1. Install the rubber grommets, and eyelets on the servos.
2. Center the servos and install the servo arms.
3. Mount the control balls on the swashplate servos in the 4th hole, the furthest from center.

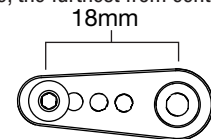

4. Mount the control ball on the tail servo in the 3rd hole from center.
5. Install the tail servo onto the tail servo mounts with M3 x 10mm screws and carbon servo plates.

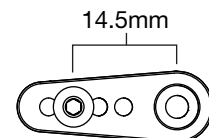

Servo Mounting (Bag A, M)

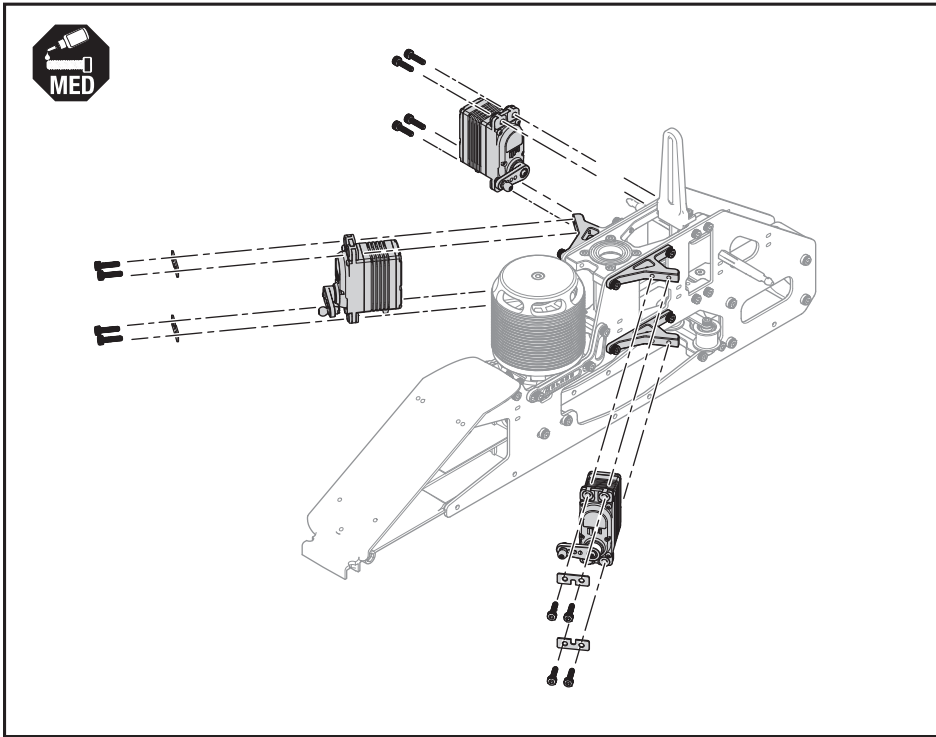

Bag A2

Install the servos on the mounting brackets with M3 x 12 screws, M3 washer, and carbon servo mount plates.

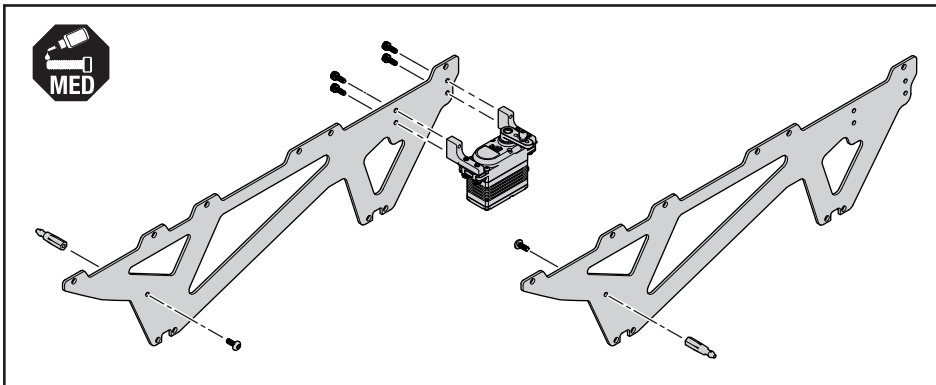

Bag M2, M9

Install the tail servo mount to the lower frame with M3 x 8mm screws and front canopy mounts to the lower frame panels.

Bags M6

Mount the lower frame panels to the upper frame assembly with M3 x 30mm screws and frame washers.

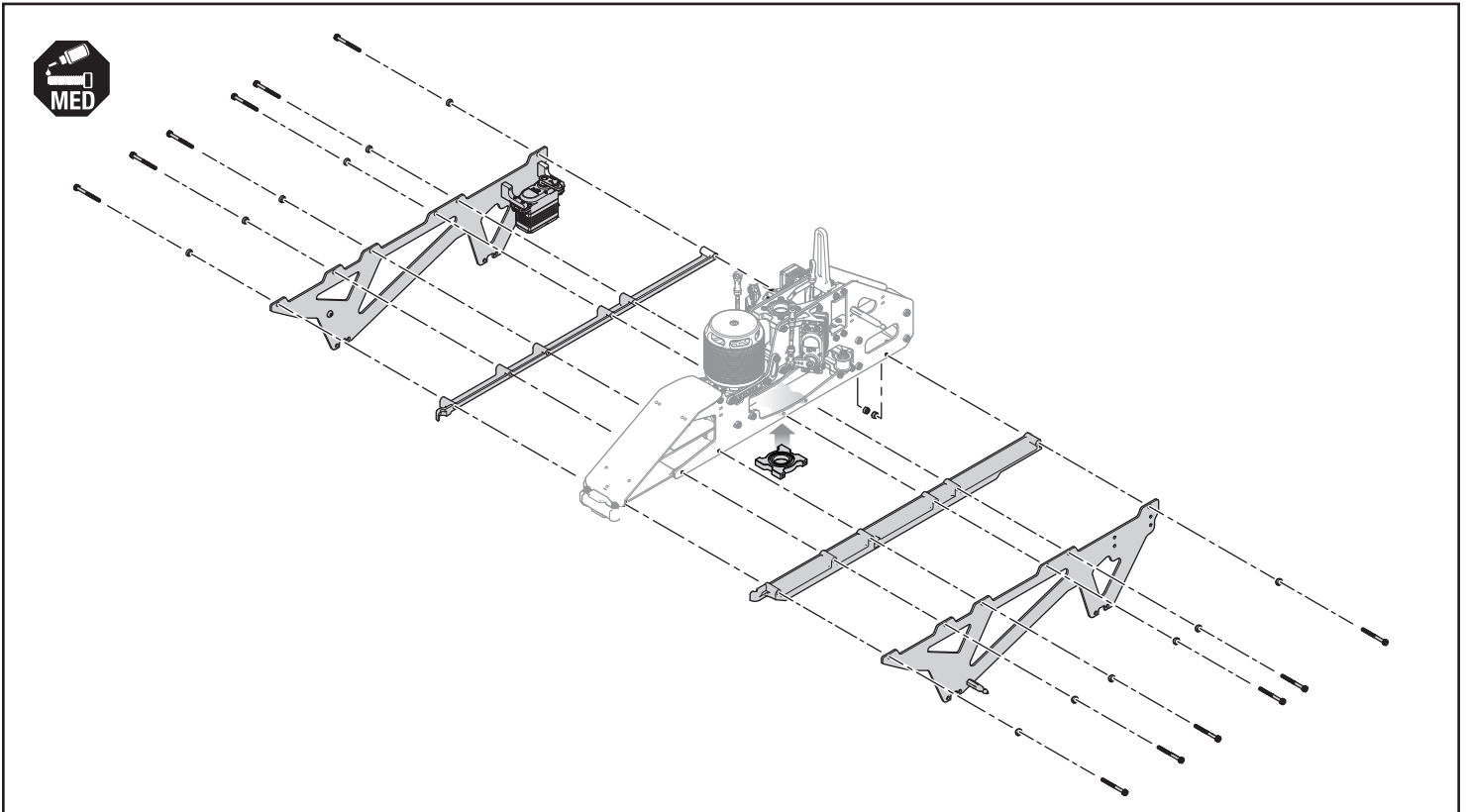

Landing Gear (Bag M)

Bags M9

Install the landing gear mounting brackets with M3 x 8mm screws and frame washers into the lower frame.

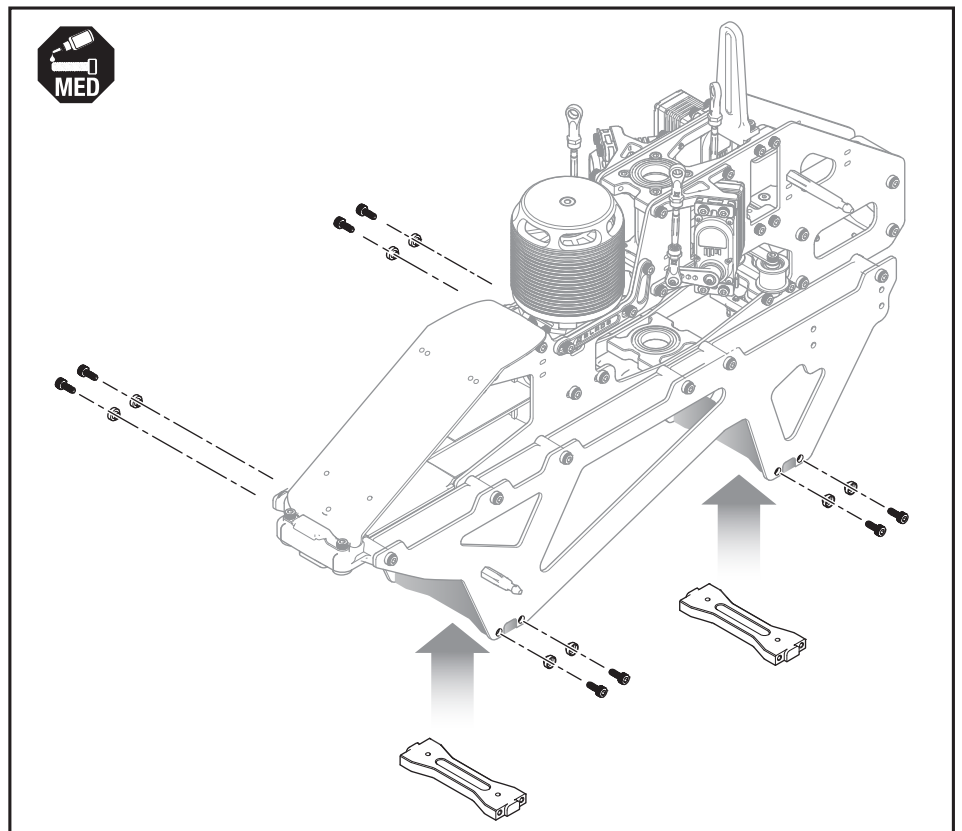

Bags M10

Mount the landing gear onto the landing gear mounting brackets with M3 x 12mm screws.

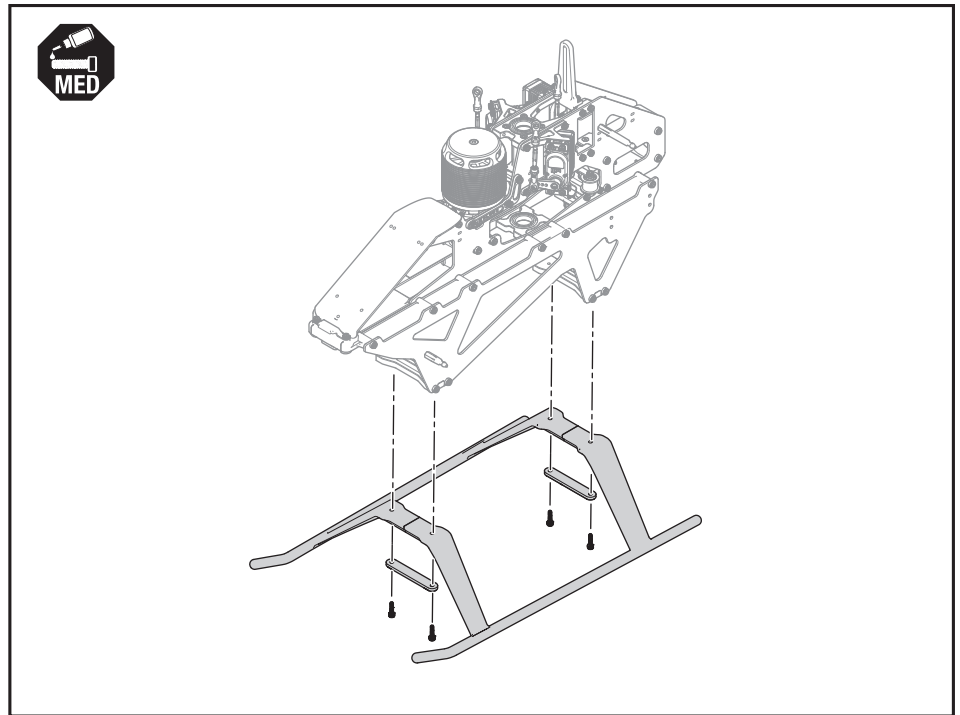

Main Gear Installation (Bag M)

Bags H2, H4, T1

1. Insert the belt through the tail boom clamps and pull the belt out through one side.
2. Place the main gear drive within the belt loop and locate the gear with the belt around it in the main frame.
3. Insert the main shaft through the main gear assembly and install the main bolt through the main gear assembly.

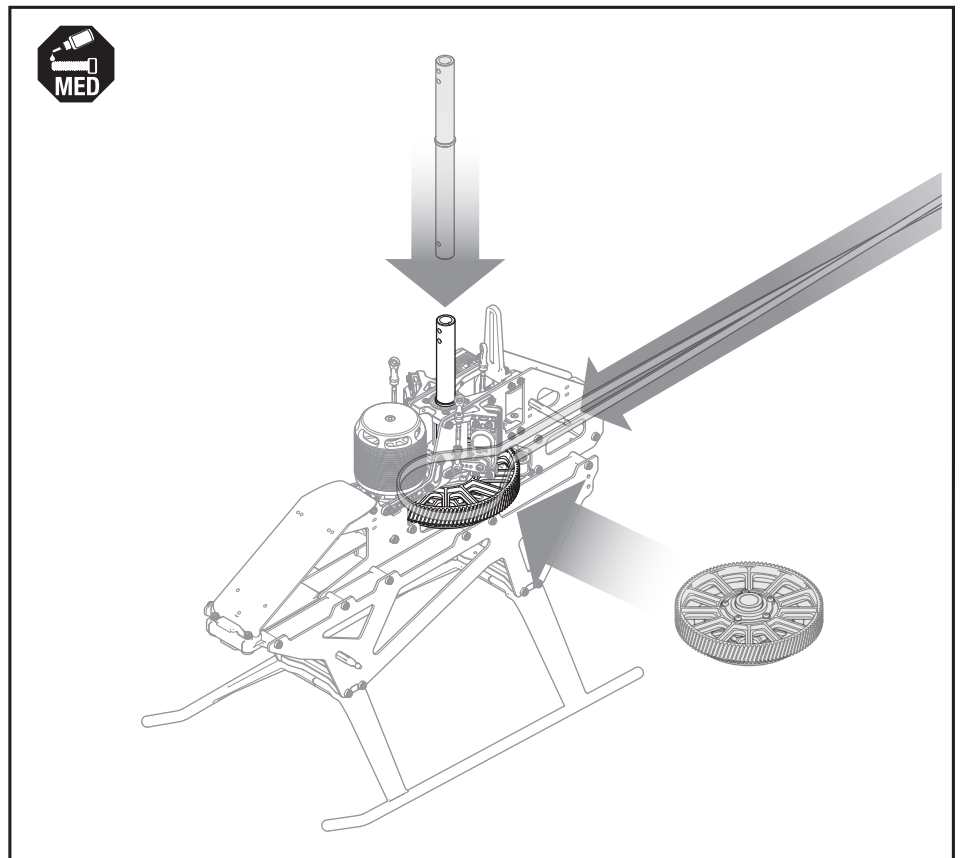

Install ESC

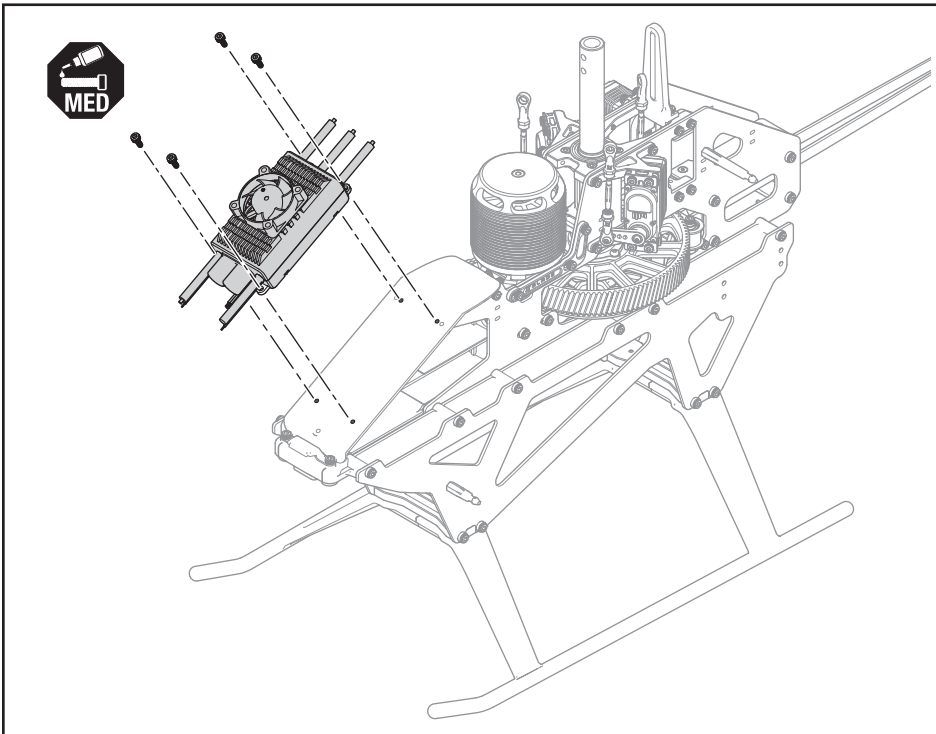

Attach the ESC to the ESC tray.

Main Rotor (Bag H)

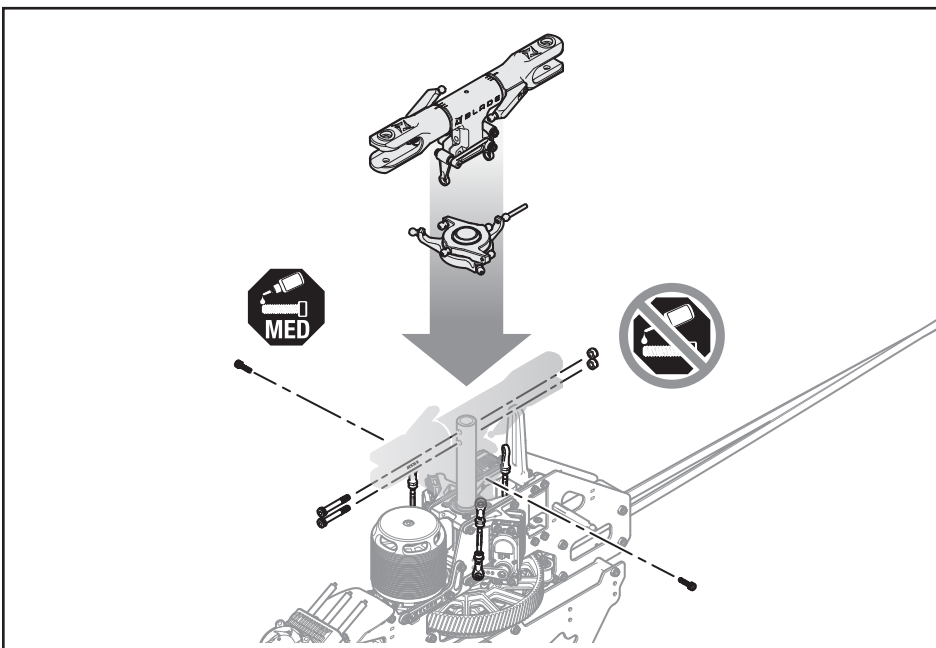

Bag H1, H3

1. Secure the main rotor head to the main shaft with two M4 x 26mm main shaft bolts and nuts **WITHOUT** thread lock.
2. Tighten the M3 x 14mm head block clamping screws with thread lock.
3. Connect the linkages from the servos to the swashplate. These should be 67mm center to center.

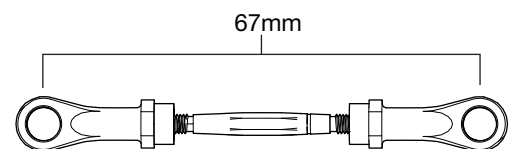

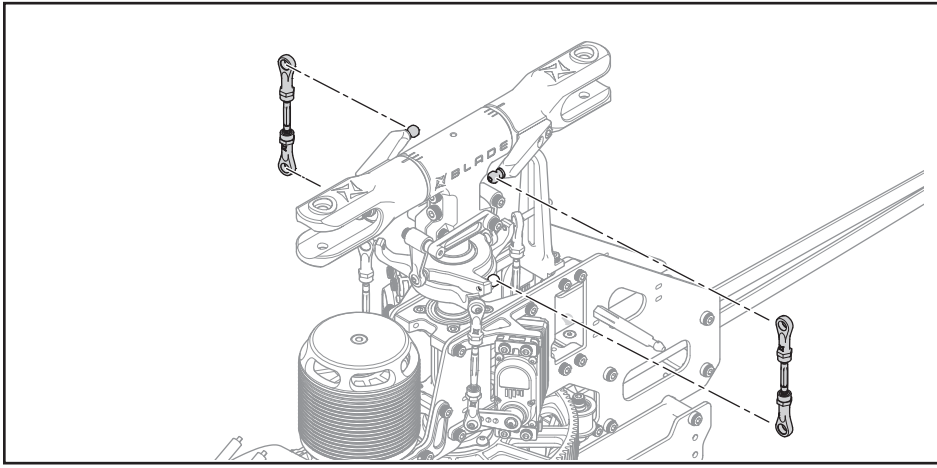

Bag A1

1. Install the swashplate to main blade grip linkages. These should be 60mm center to center

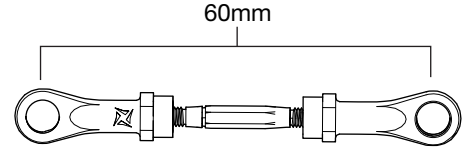

Tail Assembly (Bags B, M, T)

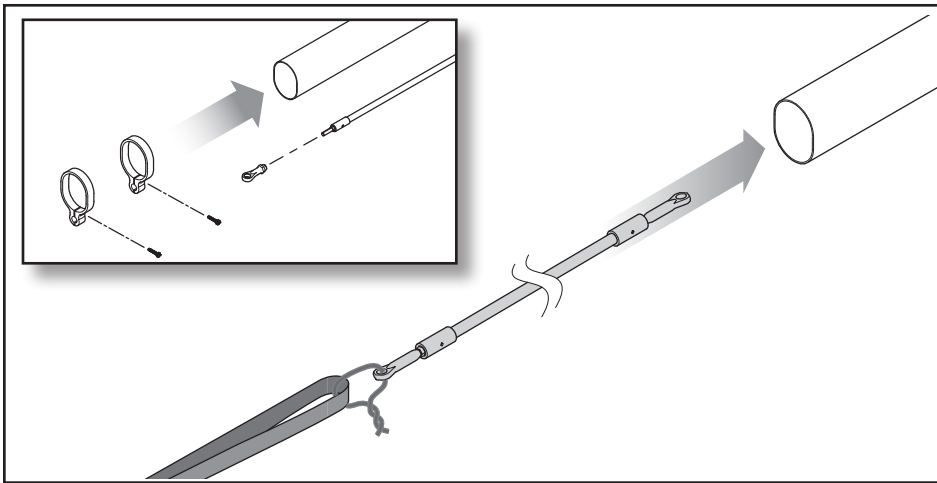

Bag A3, B, B1

1. Slide the pushrod supports onto the boom and secure each in place with an M2 x 10mm screw.
3. The front of the boom has no mounting holes, the rear has four mounting holes for the tail case. Use a twist tie or zip tie to feed the pushrod through the boom and pull the belt through.
4. Slide the boom into the mounts.
5. When the boom is fully seated in place, the tail belt should extend from the back of the boom as shown. Rotate the rear loop of the belt 90° counter clockwise from horizontal, when viewed from the rear of the aircraft. Ensure the belt is not twisted inside the boom.

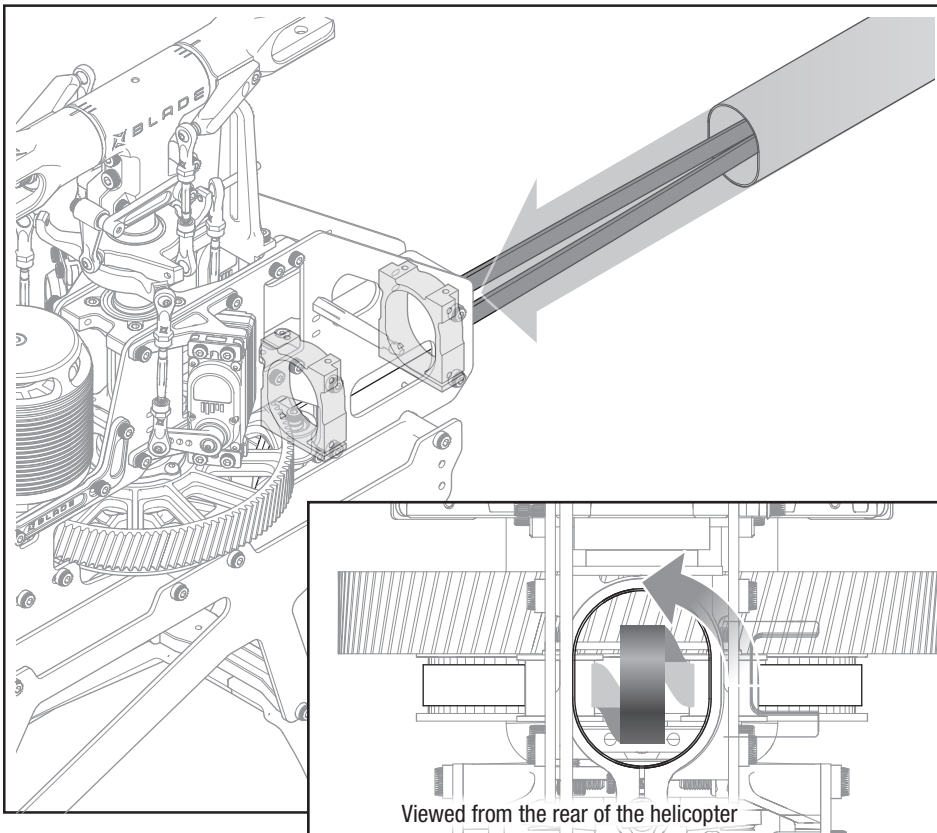

Viewed from the rear of the helicopter

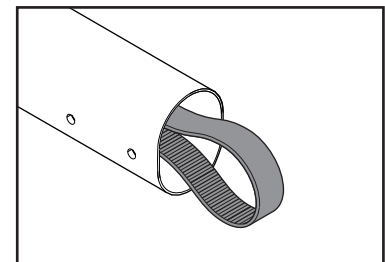

Bag T2

1. Install the pivot block for the tail pitch slider. The mounting screws insert from the left side of the tail case and pass through the case to install the block on the right side of the tail case.

Install the tail fin and mounting screws for the tail case to secure the tail case in place.

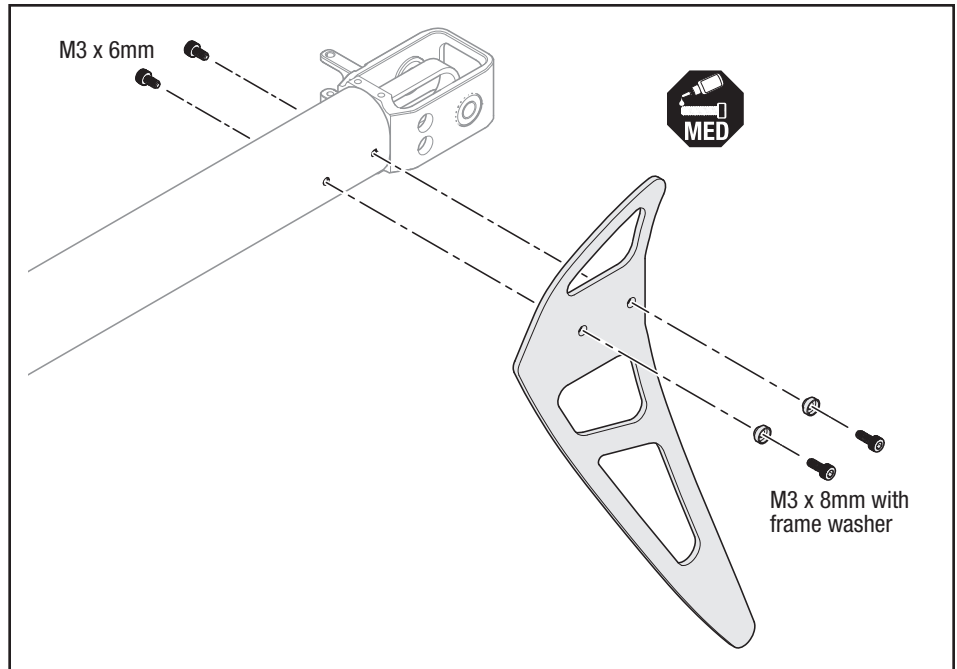

Bag T5

1. Insert the tail pulley into the loop created by the tail belt from the bottom.
2. Slide the tail shaft in from the right side, through the tail pulley and into the left side tail case bearing.

IMPORTANT: Remove one of the set screws from the pulley to view the flat spot on the shaft. Tighten the opposing set screw when the flat spot is centered, then re-install the set screw.

3. Tighten the M4 x 4mm set screw.

Check the rotation of the tail pulley. The tail pulley should rotate as shown when the main rotor is rotated clockwise, when viewed from above. If the tail gear does not rotate as shown, remove the tail shaft and tail pulley, rotate the tail belt loop 180° and re-assemble.

Sight down the tail boom and ensure the tail belt is not twisted more than 90° inside the tail boom.

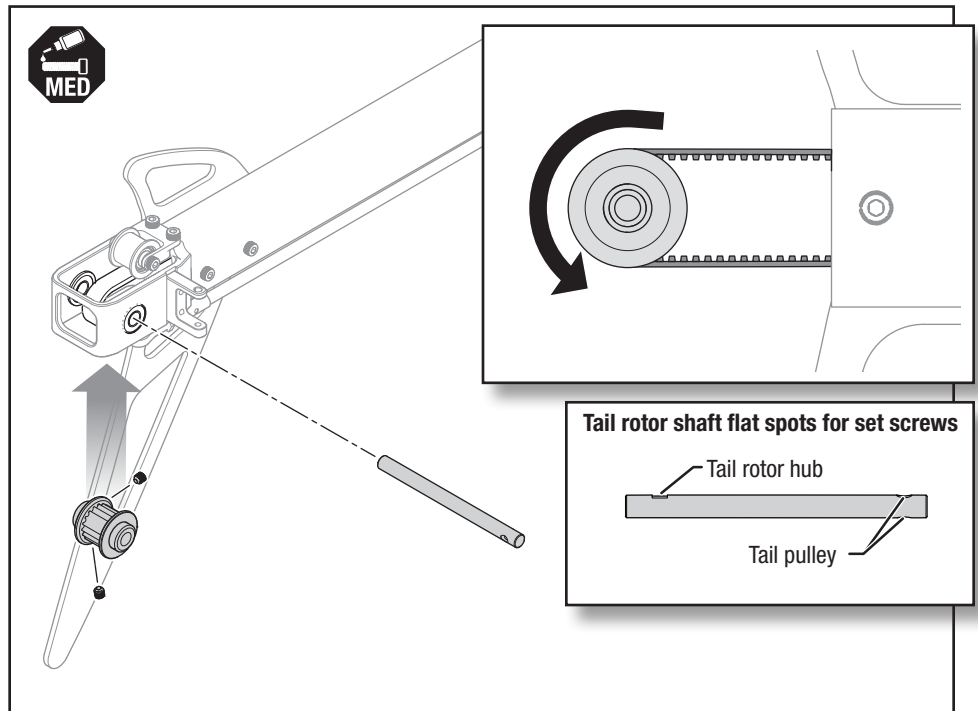

Bag T3

1. Slide the tail pitch slider onto the tail shaft and align the slot for engagement with the threaded holes in the bellcrank.
2. Install the threaded pins into the bellcrank so they engage with the tail pitch slider.

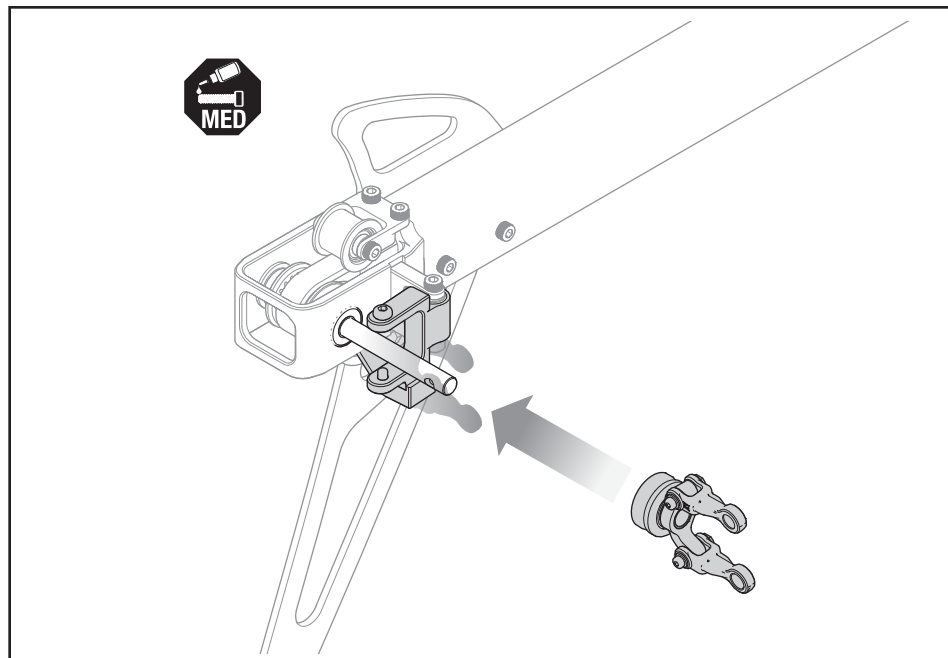

Bag T4

Install the tail hub on the tail shaft by securing the M4 x 4mm set screws with thread lock.

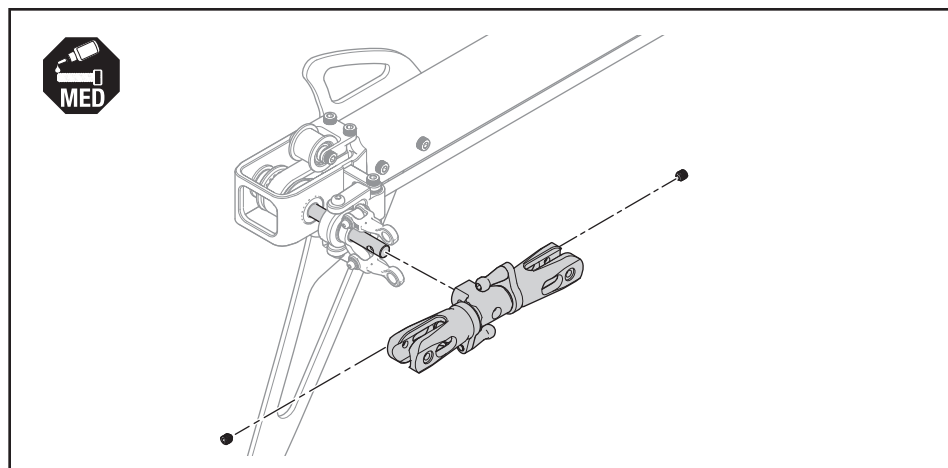

Belt Tension

1. Check the belt tension just behind the main gear at the rear of the side plate opening. Push inward on the belt from the side with moderate pressure. The belt should not deflect more 4mm.
2. Set the tail belt tension by pulling the boom away from the main frame, and tighten the two M3 x 8mm screws in the boom clamps.

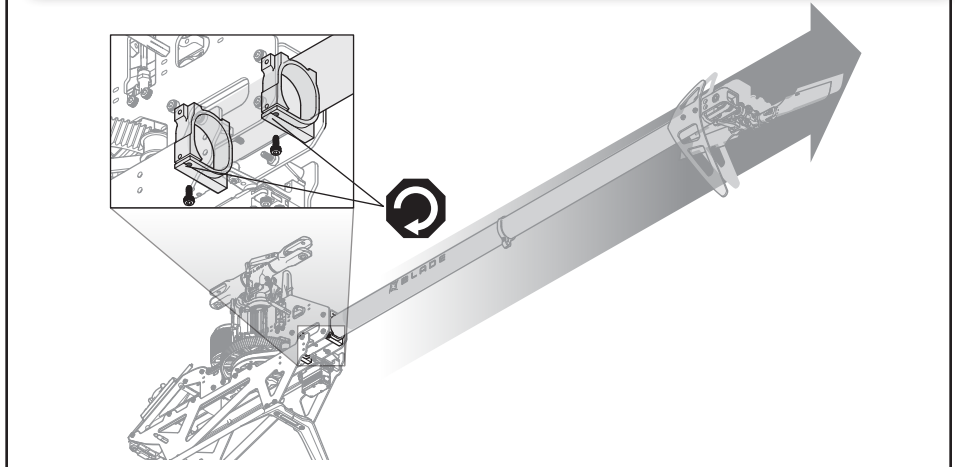
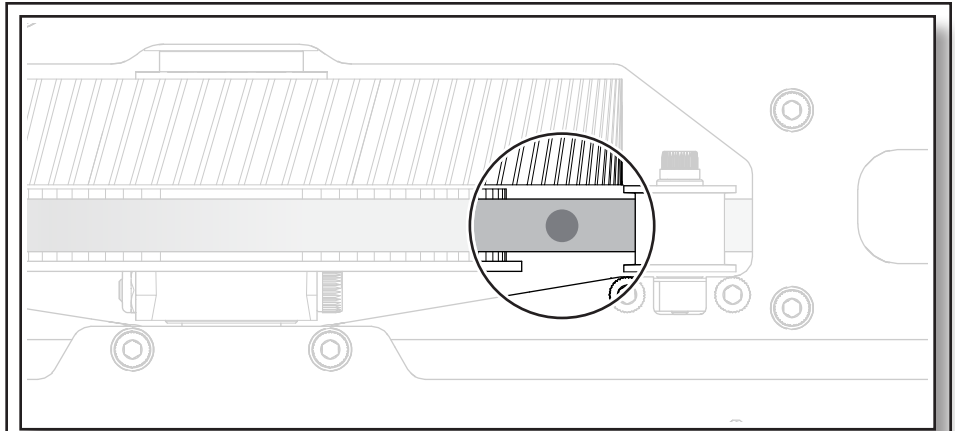

Tail Rotor Pushrod

1. Insert the metal sleeve of the tail pushrod into one of the the pushrod guides.
2. Secure the pushrod guide with the 2mm screw clamping the support.
3. Snap the front tail pushrod linkage onto the tail servo arm.
4. Snap the rear pushrod linkage onto the tail rotor pitch lever.

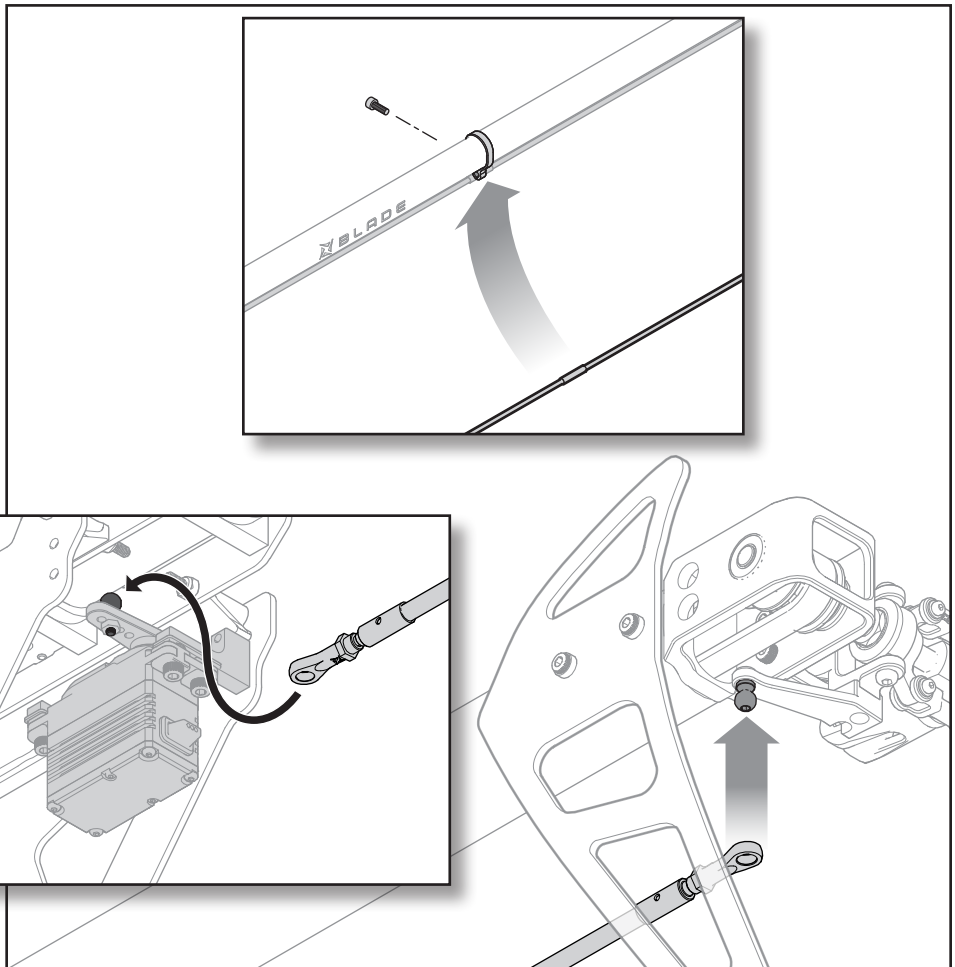

Flight Controller Mounting Plate

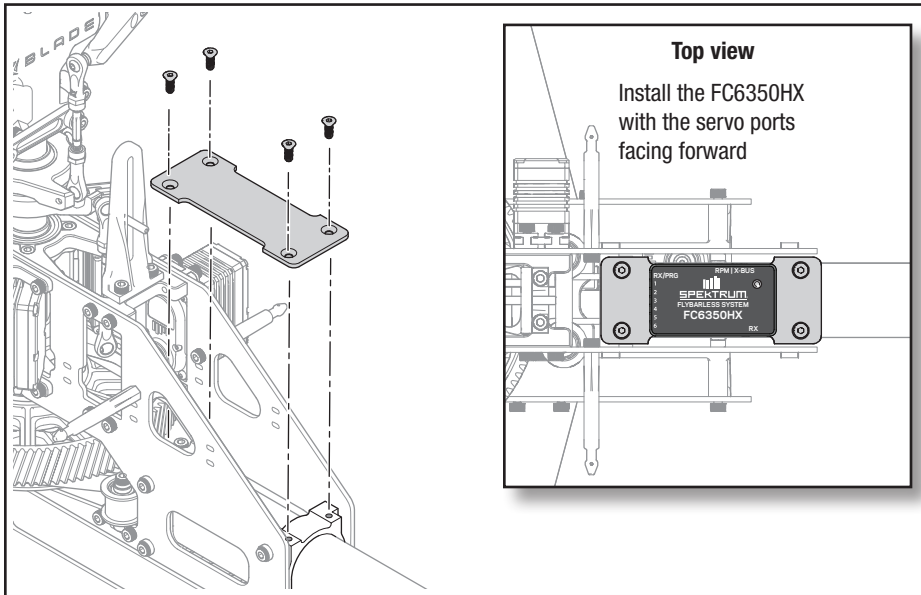

Bag M7

1. Route the servo and throttle wires to the flight controller mounting area of the frame. Small holes are provided in the frame side plates to allow for securing the servo wires with small plastic cable ties. When routing the wires, be very careful to avoid any moving parts and sharp edges of the carbon fiber plates.
2. Attach the flight controller mounting plate to the top of the front tail boom mounts with four M3x4mm countersunk screws.
3. Secure the FC6350HX to the mounting plate with the servo ports facing forward using the double sided tape provided with the flight controller.

IMPORTANT: Mount the flight controller square with the frame.

Main and Remote Receiver Mounting

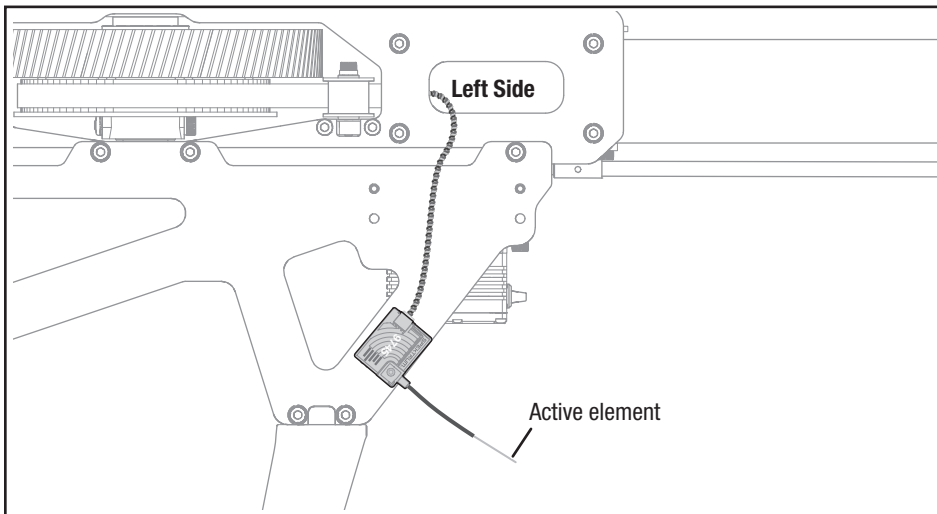

Use double-sided mounting tape to install the 9745 remote receiver on the left side of the frame, and the 4651T main receiver on the right side of the frame, as shown.

Antenna Installation

The 9745 and 4651T receivers have a coaxial style antenna. We recommend installing the antennas as shown in the illustration to maximize signal reception. Use mounting tape to secure the longer antennas on the 4651T so the active elements at the end of the coaxial cables are not mounted next to the carbon fiber frame.

NOTICE: Do not cut, kink, or modify the antenna. Damage to the coaxial portion of an antenna will reduce the performance of the antenna. Shortening or cutting off the 31mm tip will reduce the range.

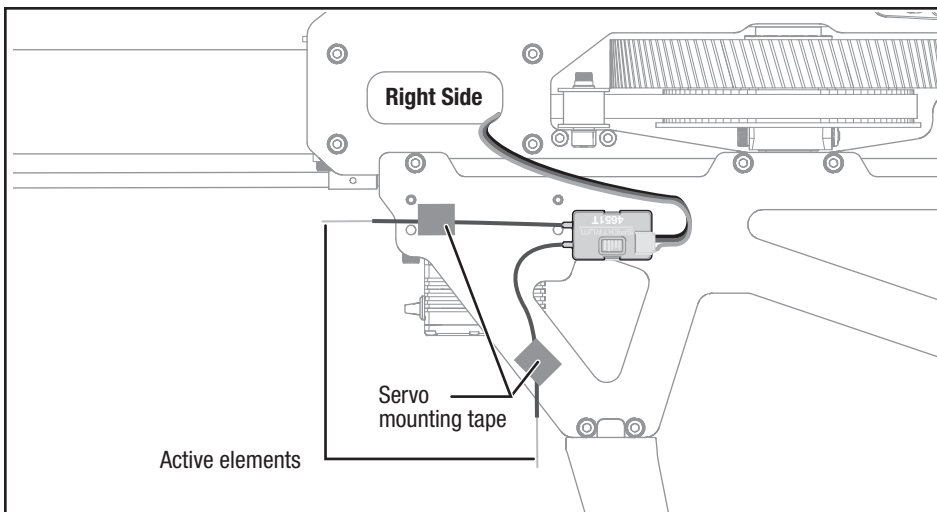

Battery Installation

1. Apply the loop side of adhesive backed hook and loop material to the flight battery.
2. Apply the hook side to the battery plate on the side opposite the plastic battery latch.
3. Attach the flight battery to the battery plate.
4. Secure the battery with the hook and loop straps.
5. Slide the battery plate into the frame with the plastic latch on the plate facing up.
6. Pull up on the latch release while pushing the tray back to engage the battery tray latch.
7. Pull up on the latch release while pulling down and forward on the battery tray to remove the battery tray.



CAUTION: Always disconnect the Li-Po battery from the electronic speed control when not flying to avoid over-discharging the battery. Batteries discharged to a voltage lower than the lowest approved voltage may become damaged, resulting in loss of performance and potential fire when batteries are charged.

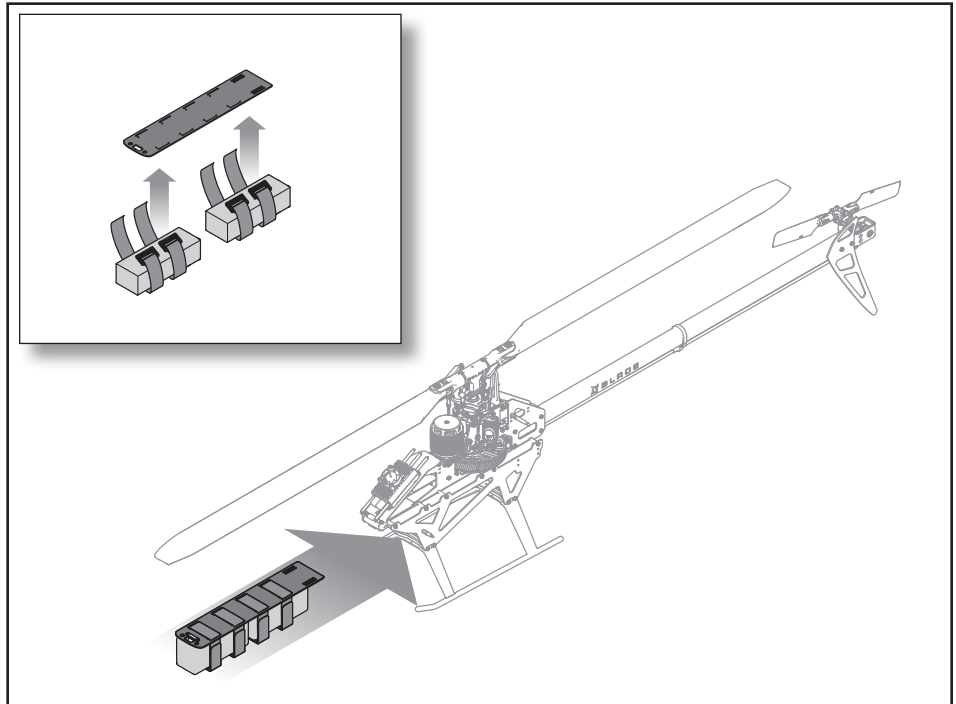

Throttle Hold

Activating and using the Throttle Hold (TH HOLD) function in your chosen transmitter is required for safe setup and operation. Throttle hold only cuts power to the motor on an electric helicopter. Pitch and direction control are maintained.



WARNING: Always engage throttle hold before approaching the helicopter.

The blades will spin if TH HOLD is OFF. For safety, turn TH HOLD ON any time you need to touch the helicopter or check the control directions.

Additionally, turn TH HOLD ON to cut power to the motor if the helicopter is out of control, in danger of crashing, or both.

Setup for FC6350HX Flight Controller

Flight Controller Setup



WARNING: Always remove the pinion gear or disconnect the main drive motor from the ESC to disengage the drive system during initial setup. The main rotor blades may turn in response to setup changes or transmitter inputs. Failure to do so could result in serious personal injury or property damage.



WARNING: The following setup information is for the Spektrum FC6350HX flight controller with the Spektrum H6350 and H6360 servos and 120HV or 200HV Avian ESC from the BLH13075C and BLH13075HPC combos. If you are not using this combination of components, be sure to refer to your product manuals for proper setup information. Failure to properly set up your flight controller system may lead to an uncontrollable helicopter.

We recommend the FC6350HX Flight controller for the Fusion 700. The FC6350HX may be programmed directly through your transmitter or with a PC. We recommend updating to the most recent firmware to begin, use the SPMA3065 USB interface programming cable with your PC to register and update the Flight Controller. The PC programmer tool can be downloaded from the SPMFC6350HX product page, click on the **Manuals and Support** tab. Select **FC6350HX PC Programmer Download and Quickstart Guide** which includes both a link to download the software and the instructions for it's use. This manual covers the setup using the transmitter to configure the flight controller through Forward Programming.

The values provided for AFR, Gain (PID), Expo, Rotation Rate, etc are a starting point. Adjust to suit your preferences.

1. Connect your main telemetry receiver (SPM4651T) to the RX/PRG port, and the remote receiver (SPM9745) to the RX port as shown. You will need to be able to access the RX/PRG port later to bind the system to your radio, so be sure to leave the wiring enough flexibility to be able to access that connector.

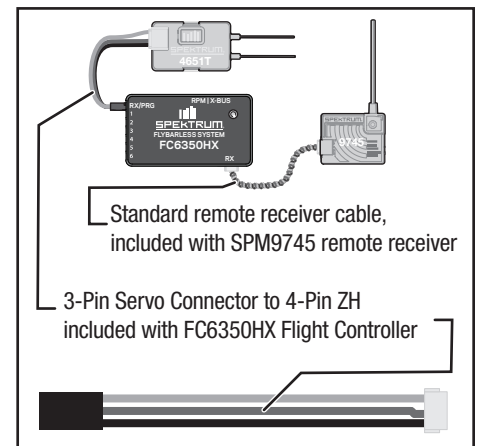

- Connect your ESC to the Flight Controller. For a Spektrum Avian Smart ESC, the throttle connector goes into the number 2 port, and the 2-wire servo lead goes into the number 6 port on the FC6350HX as shown.
IMPORTANT: If you are using an ESC without Spektrum Smart technology, refer to the FC6350HX manual for the proper ESC and servo ports.

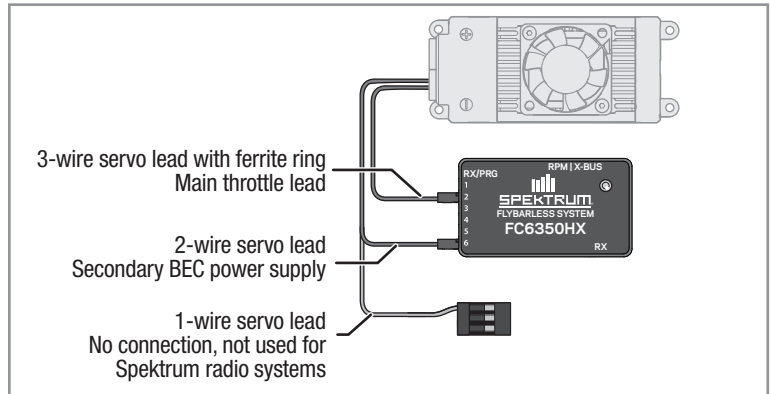

- In your transmitter, create a new heli setup and name the model file.

| SYSTEM SETUP | |
|----------------------|----------|
| Model Type | HELI |
| Swash Type | Normal |
| F-Mode Setup | |
| Switch 1 | Switch B |
| Switch 2 | Inhibit |
| Hold Switch | Switch H |
| | 0 1 |
| Channel Assign | |
| Channel Input Config | |
| 1 Throttle | |
| 2 Aileron | |
| 3 Elevator | |
| 4 Rudder | |
| 5 Gear | |
| 6 Collective | |
| 7 AUX 2 | |
| Frame Rate | |
| | 11ms |
| | DSMX |

| FUNCTION LIST | | | | | | | |
|----------------|--------------|---------------------|-----------|---------|------------|---------|------|
| Servo Setup | | | | | | | |
| Chan | Travel | Reverse | Chan | Travel | Reverse | | |
| THR | 100/100 | Normal | PIT | 100/100 | Normal | | |
| AIL | 100/100 | Normal | AX2 | 100/100 | Normal | | |
| ELE | 100/100 | Normal | AX3 | 100/100 | Normal | | |
| RUD | 100/100 | Normal | AX4 | 100/100 | Normal | | |
| GER | 100/100 | Normal | | | | | |
| D/R & Expo | | | | | | | |
| Chan | Sw (F) Pos | D/R | Expo | Chan | Sw (F) Pos | D/R | Expo |
| AILE | 0 | 100/100 | +25 | ELEV | 0 | 100/100 | +25 |
| | 1 | 100/100 | +25 | | 1 | 100/100 | +25 |
| | 2 | 75/75 | +25 | | 2 | 75/75 | +25 |
| RUDD | 0 | 100/100 | +25 | 0 | 100/100 | +25 | |
| | 1 | 100/100 | +25 | 1 | 100/100 | +25 | |
| | 2 | 75/75 | +25 | 2 | 75/75 | +25 | |
| Throttle Curve | | | | | | | |
| Sw (B) Pos | Pt 1 | Pt 2 | Pt 3 | Pt 4 | Pt 5 | | |
| ESC Setup* | 0 | 50 | 50 | 50 | 50 | | |
| Normal | 0 | 60 | 60 | 60 | 60 | | |
| 1 | 70 | 70 | 70 | 70 | 70 | | |
| 2 | 80 | 80 | 80 | 80 | 80 | | |
| Pitch Curve | | | | | | | |
| Sw (B) Pos | Pt 1 | Pt 2 | Pt 3 | Pt 4 | Pt 5 | | |
| Normal | 30 | 40 | 50 | 75 | 100 | | |
| 1 | 0 | 25 | 50 | 75 | 100 | | |
| 2 | 0 | 25 | 50 | 75 | 100 | | |
| HOLD | 25 | 37 | 50 | 75 | 100 | | |
| Gyro | | | | | | | |
| Channel: Gear | | Switch: Flight Mode | | Th Hold | | | |
| Normal | Idle Up 1 | Idle Up 1 | Idle Up 2 | | | | |
| 87% | 87% | 87% | 87% | 87% | | | |
| Timer | | | | | | | |
| Mode | Count Down | | | | | | |
| Time | 5:00 | | | | | | |
| Start | Throttle Out | | | | | | |
| Over | 25% | | | | | | |
| One Time | Inhibit | | | | | | |

- Bind the transmitter to your flight control system.
 - Remove the SPM4651T receiver connector from the RX/PRG port.
 - Insert a bind plug into the RX/PRG port.
 - Connect a battery to the ESC, the LED on the 9745 remote receiver will begin to flash indicating the receiver is in bind mode.
 - Leave the battery and remote receiver powered on, remove the bind plug.
 - Press and hold the bind button on the 4651T main receiver and insert the connector into the RX/PRG Port.
The LED will begin to flash indicating the receiver is in bind mode, release the bind button once the LED begins to flash.
 - With your throttle at zero, put your transmitter into bind mode, the LEDs on the receivers will stay illuminated when the connection is successful.
- Ensure your throttle hold is enabled. In your transmitter menu, select **Forward Programming**. The transmitter connects to the flight controller, and a menu is displayed.
- Navigate to the **Setup→Swashplate→Output Setup** menu.
- Set the **Frame Rate** to 333Hz.

- Select the **Type** menu. Select the 3 servo 120° swashplate option that shows the B servo connection in the rear of the swashplate.
- Connect the servos as shown and verify it matches what is shown on your transmitter. The servos will respond to the control sticks and should be centered when the throttle stick is centered. **IMPORTANT:** You are required to center the servo arms on the servos during installation, as described in this manual. If a servo arm is not centered when the throttle stick is centered, re-center the servo arm on the servo before proceeding. Select **Back**, and navigate to the **Direction** menu.

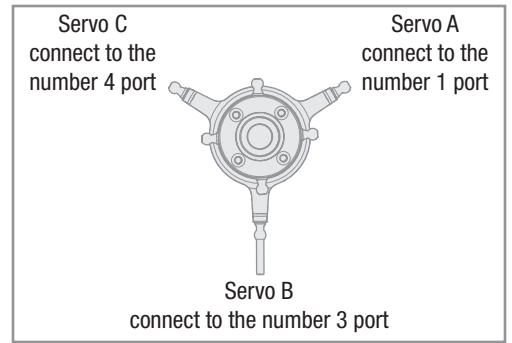

- Set servo reversing in the forward programming menu so Output Channel 1 is set to **Reverse**. Set Output Channel 2 and 3 to **Normal**. The swashplate servos must move the swashplate up with positive collective pitch movement. **IMPORTANT:** Servo reversing should only be done within the Forward Programming menu, do not change servo reversing in the transmitter's servo menu. Select **Back** to return to the previous menu.

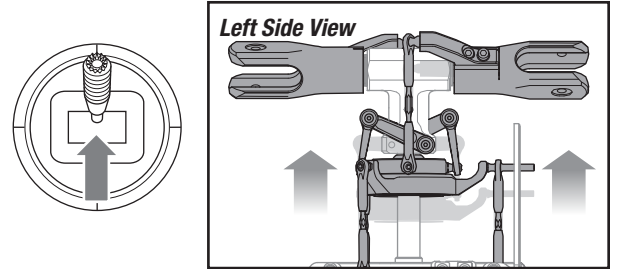

- Select the **Sub Trim** menu. The swashplate servos move to the center position. Use the sub trim adjustments to ensure the servos are level. Before exiting the menu, ensure the main rotor blades are at 0° collective and the swashplate is level in the roll and pitch axis. When the notches on top of the blade grips and rotor hub are aligned the blades are at 0° collective pitch, as shown in the image. Select **Back** twice to exit the **Swashplate → Output Setup** menu.

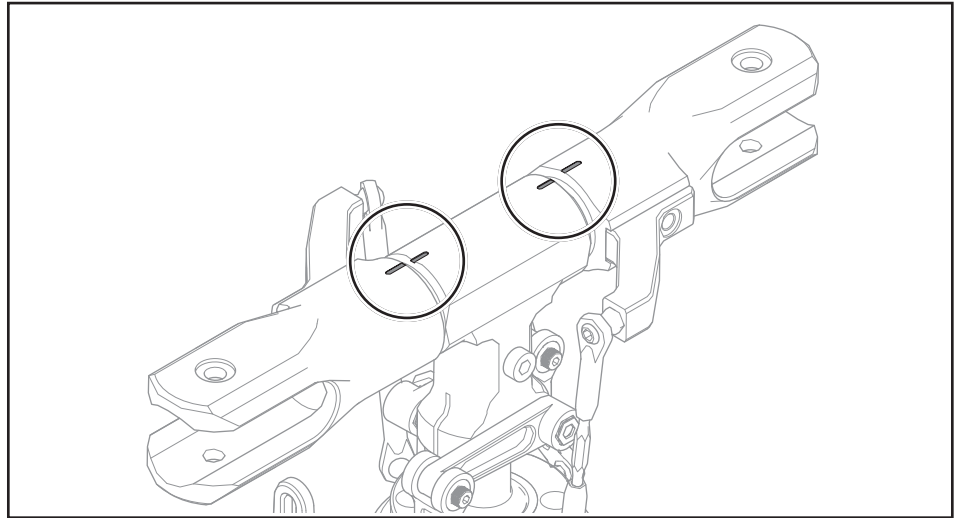

- Select the **AFR** menu. Set the Roll to 75, and the Pitch to 75. Verify that the roll and pitch cyclic are moving in the correct direction by moving the cyclic stick. If you do not achieve proper control, review the swashplate selection and servo ports at steps 8 and 9. Once the directions are correct, center the collective stick on the transmitter.

Elevator, Forward and Back Cyclic

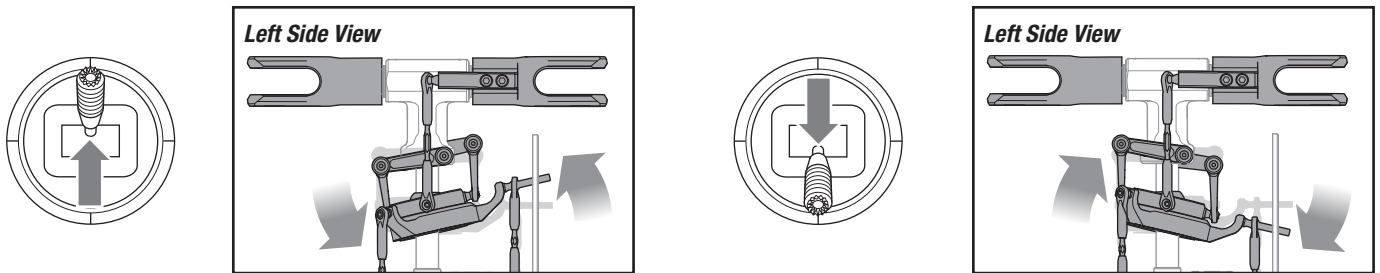

Aileron, Left and Right Cyclic

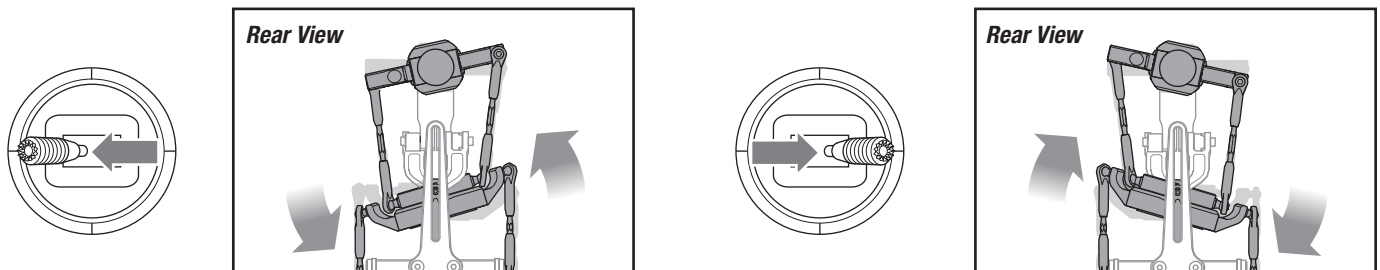

13. The AFR values provided in the previous step should be a good starting point, but we recommend verifying with a digital pitch gauge on your helicopter. Place a pitch gauge on a main rotor blade, ensure the throttle stick is exactly centered and the blades are at 0°. The throttle stick needs to remain centered when setting AFR values.
- Rotate the main blades so they are perpendicular to the frame, apply full right cyclic, and adjust the AFR value for roll until your pitch gauge reads 12.5°.
 - Rotate the main blades so they are parallel to the frame. Apply full aft cyclic, and adjust the AFR value for cyclic pitch until your pitch gauge reads 12.5°.
14. Adjust the **Collective AFR** value to set your collective pitch range. We recommend starting with +47 and adjust the pitch range to suit your needs. You may set it as low as +/- 10° for sport flying or as high as +/- 14° for aggressive performance. We recommend +/- 12° as a starting point. Your skill level as a 3D pilot will determine how much pitch is acceptable. Proper collective management skills are required to utilize more than +/- 12 degrees.. If you cannot get equal positive and negative values, use the differential value to adjust the endpoints. The differential value does not change the center position, only shift the endpoints. Remove the pitch gauge. Select **Back** twice to return to the **Setup** menu. The swashplate setup is complete.
15. Navigate to the **TailrotorOutput**→**Setup** menu.
16. Set the **Frame Rate** to 560Hz.
17. Connect the tail rotor servo to the number 5 port on the FC6350HX.
18. Navigate to the **Direction** menu. Set the direction to reverse. Move the tail rotor stick on the transmitter to the right. Observing from behind, the tail pitch slider should move to the left. If not, reverse the channel direction on the FC6350HX. Select **Back** to return to the previous menu.
19. Select **Subtrim** to center the tail rotor servo. Select **Back** to return to the previous menu.
20. Select the **Travel** menu.
- Select **Left** travel. Hold the transmitter tail rotor stick full left, and adjust travel to ensure full travel and that no binding occurs.
 - Select the **Right** travel. Hold the transmitter tail rotor stick full right, and adjust travel to ensure full travel and that no binding occurs.
- Press **Back** twice to return to the **Setup** menu. Tailrotor setup is complete.
21. Select **Main Menu**→**Swashplate**→**Roll** and set P to 45, I to 70 and D to 5.
22. Select **Main Menu**→**Swashplate**→**Pitch** and set P to 65, I to 85 and D to 20.
23. Select **Main Menu**→**Swashplate**→**Agility** and set to 80.
24. Select **Main Menu**→**Tail Rotor** and set Degrees°/per second to 515, start and stop to 20, P to 85, I to 150 and D to 10
25. Exit **Forward Programming**. We recommend testing failsafe operation before proceeding. Remove the pinion gear and then run the motor. Power off the RF on your transmitter, your motor should shut off. If it does not, rebind the system with the throttle off and test again. Reinstall the pinion gear.
26. Once your throttle failsafe test is complete, enter **Forward Programming** mode, and select the **Setup**→**Throttle**→**Failsafe** menu.
27. Lower the throttle stick to the full stop position, and select **Capture** to record the throttle failsafe position. Select **Back** to return to the **Setup**→**Throttle** menu.
28. Select **Throttle**→**Hover**
- This setting is the throttle point where your model hovers in normal mode, mainly during takeoff and landing. The flight controller applies special anti roll over algorithms at or below the throttle setting, helping to make takeoffs and landings easier. The Stunt 1 and Stunt 2 throttle curves should be above the hover throttle setting to ensure the roll over mitigation is disabled in flight. During the initial setup, you can set **Throttle**→**Hover** to a high value of 65% and normal offset 0%. Once the throttle setting is determined for hovering in normal mode, set the **Hover Throttle** value. Select **Back** to return to the **Setup** menu.
29. Select the **Gyro Settings**→**Orientation Menu**, and set the mounting orientation to match the FC6350HX mounting orientation on your helicopter. Once complete, physically move the helicopter on each axis to ensure the gyros are compensating in the correct direction. If you update your FC6350HX to the newest firmware (version 5.5 or newer) the system will ask you to perform the sensor calibration after setting the sensor mounting orientation. Level the side of the FC6350HX that faces upwards and select **Apply** to complete the sensor calibration step. With firmware version 5.4 or earlier the calibration step after changing the sensor orientation is not necessary. Select **Back** twice to return to the **Setup** menu.
30. Select the **FM Channel** and select **Inhibit**. After initial test flights, if you would like to use individual gains for cyclic per flight mode, set the FM Channel within the **Setup** menu.
31. The **Gain Channel** defaults to the gear channel. This is the transmitter gyro gain channel for the tail rotor. Adjust the tail gain value for each flight mode during flight testing to maximize tail holding performance without introducing a tail wag.
32. Press **Back** to exit the forward programming menu, and save the parameters. The FC6350HX flight controller setup is complete.
33. Optional SAFE setup requires the FC6350HX is tuned for normal flight before you can set up SAFE, please refer to the FC6350HX manual for more details.

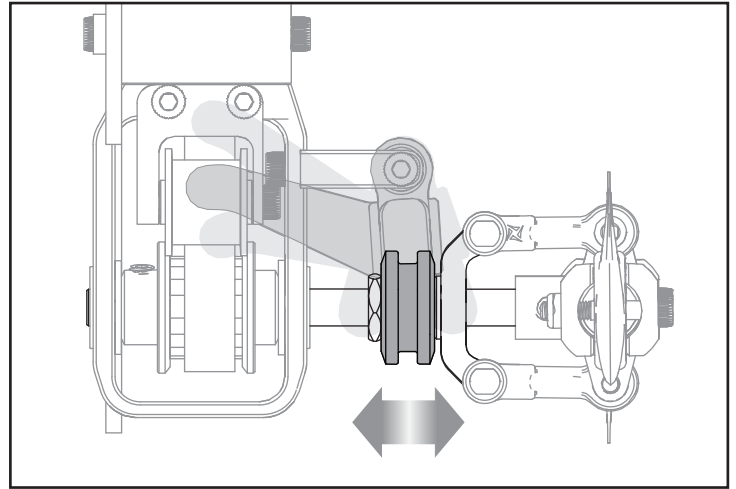

Control Tests



CAUTION: You must complete the Rudder and Cyclic tests prior to attempting flight. Failure to ensure the sensor directions are not reversed can cause the helicopter to crash, resulting in property damage and injury.

Rudder

1. Power on the transmitter.
2. Turn TH HOLD ON and set the flight mode to NORMAL.
3. Connect the helicopter battery to the ESC and allow the flight controller to fully initialize.
4. **Rudder channel test:**
Move the rudder stick to the right. The tail pitch slider should move towards the tail boom.
Move the rudder stick to the left. The tail pitch slider should move away from the tail boom.
If the slider does not move in the desired direction, review step 17 in the **Setup for FC6350HX Flight Controller** section of this manual.
5. **Flight controller sensor test:**
Release the rudder control. Manually turn the helicopter counterclockwise when viewed from above. The tail pitch slider should move towards the tail boom.
Manually turn the helicopter nose clockwise. The tail pitch slider should move away from the tail boom.
If the slider does not react in the proper direction, review step 24 in the **Setup for FC6350HX Flight Controller** section of this manual.

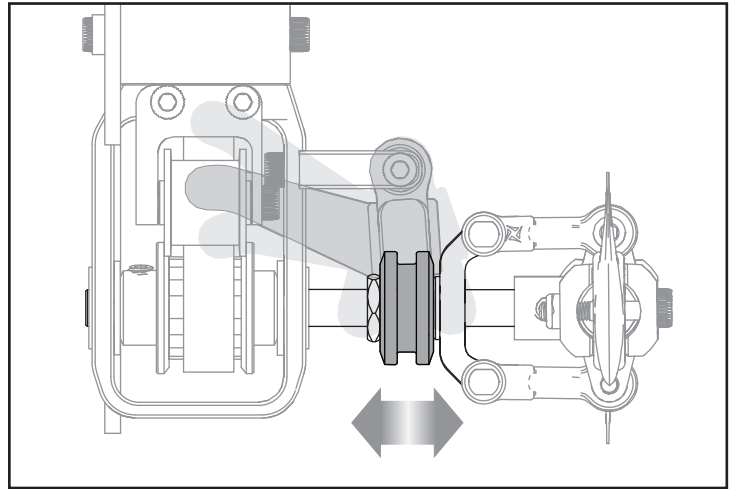

Cyclic Sensor Test

From the back of the helicopter:

1. Tilt the helicopter forward. The swashplate should tilt backward.
2. Tilt the helicopter backward. The swashplate should tilt forward.
3. Roll the helicopter left. The swashplate should roll right.
4. Roll the helicopter right. The swashplate should roll left.
5. If the swashplate does not move in the correct direction, review step 24 in the **Setup for FC6350HX Flight Controller** section of this manual.

Motor Direction Test

Place the helicopter outdoors on a clean, flat and level surface (concrete or asphalt) free of obstructions. Always stay clear of rotating parts.

1. Power on the transmitter. Make sure TH HOLD is ON and the flight mode switch is set to NORMAL.



WARNING: The motor and rotors will spin when throttle is increased and TH HOLD is OFF.

2. Lower the throttle completely.
3. Connect the Li-Po battery to the ESC.
4. Turn TH HOLD OFF. Slowly increase the throttle until the drive train begins to turn. The main rotor should spin clockwise when viewing the helicopter from the top. The tail rotor should spin counterclockwise when viewing the helicopter from the right side.

5. If the drive train does not turn with the motor or the main rotor spins counterclockwise, turn TH HOLD ON and reverse the motor. The Avian 120HV or 200HV ESC can reverse the motor direction from the transmitter based programming or the Avian programming box (SPMXCA200). Or, the wiring between the ESC and the motor may be changed. To change the motor wires disconnect the battery from the helicopter and reverse any two motor wire connections to the ESC and repeat the motor control test.

Tail Rotor Blade Installation

Install the tail blades in the orientation shown using a 2.5mm hex driver and M3x12mm bolts and locknuts. **Do not apply thread lock compound to the bolt and lock nut.**

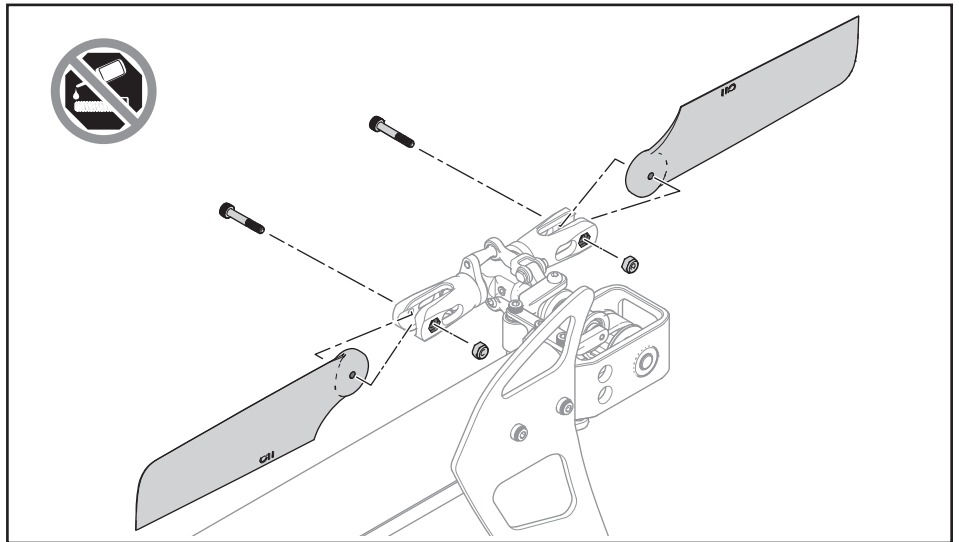

Main Rotor Blade Installation

Install the main rotor blades in the orientation shown using a 4mm hex driver to install the M4x30mm bolts and locknuts.

Do not apply thread lock compound to the bolt and lock nut.

Do not over-tighten.

- The rotor blades should be tight enough to hold their position if you hold the helicopter sideways and remain in position even if the helicopter is shaken abruptly. The exact tension is not as important as ensuring both blades are at the same tension.

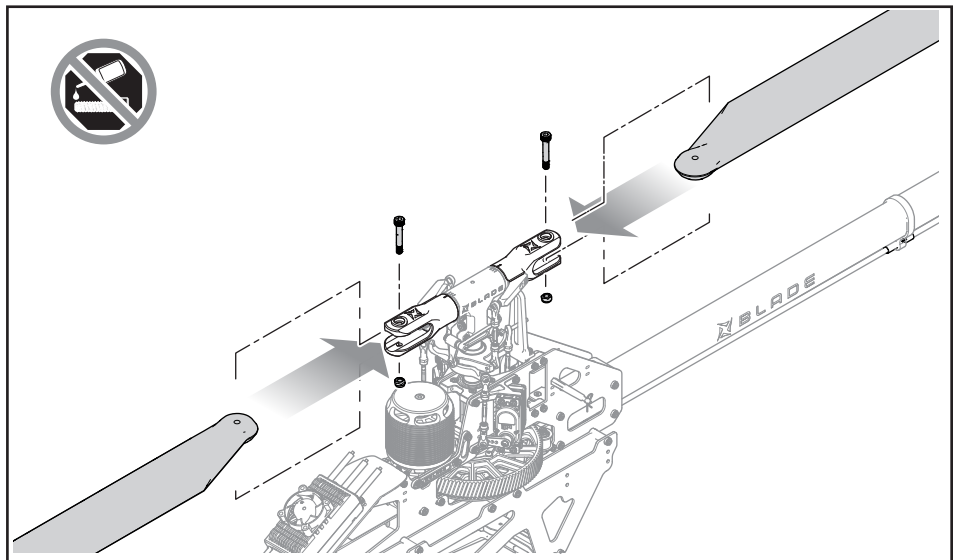

Canopy Installation

1. Install the four canopy grommets into the canopy from the inside. Secure the grommets with medium CA.
2. Install the canopy by sliding the canopy grommets over the corresponding canopy posts as shown.

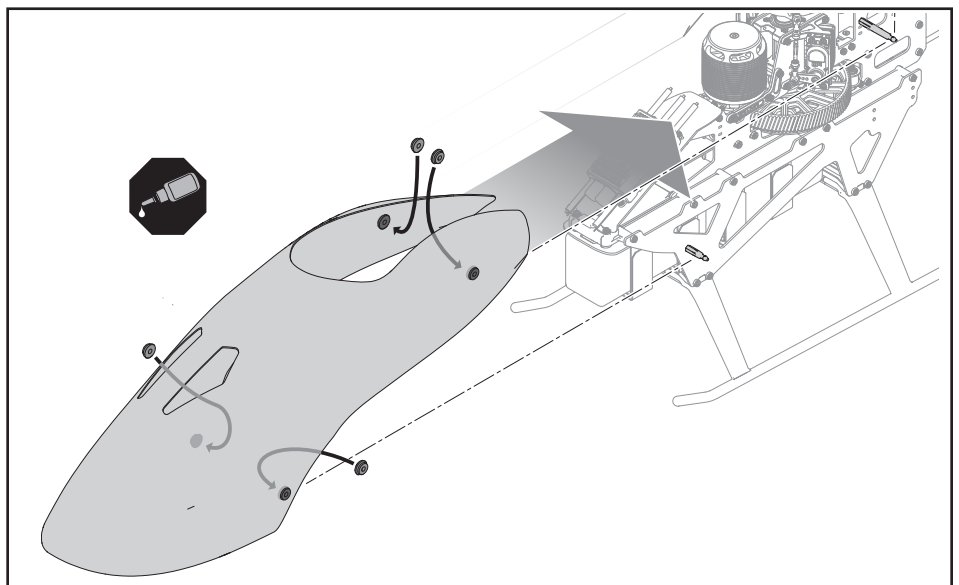

Settings for Avian ESC

We recommend the Avian 120HV or 200A ESC for your Fusion 700. The Avian may be programmed directly through your transmitter or through a programming box (SPMXCA200).

- Use the optional ESC programming box or access the ESC programming page from your transmitter's telemetry screen. To access the ESC programming from your transmitter, begin with the model connected to your transmitter. From the main screen scroll past the Smart telemetry menus to access the ESC programming page. Hold the sticks as shown to access the menu.
IMPORTANT: Do not power the motor on before attempting to enter ESC programming, the programming menu is locked once the motor is powered on. If you need to enter ESC programming after the motor has been powered, you must power cycle by unplugging the battery and plugging it in again.
- Set the parameters as shown in the table at the right.
- Use the normal throttle curve set for ESC programming during radio setup (0 50 50 50 50). Do not change to idle up throttle curves while running the motor for this procedure.
- Select a safe location to test the helicopter outside with a flat surface. Spool up the helicopter on the ground in normal mode, keeping the throttle at half stick (zero pitch) so the helicopter does not lift off, and let it spin for at least 20 seconds. Power the motor off and disconnect the battery.
- Reset your normal throttle curve to (0 60 60 60 60) for flight.

The cooling fan port is used to program the ESC with the optional SPMXCA200 ESC programming box.

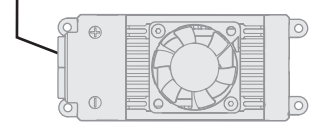

| Programming Parameter | |
|-----------------------|--------------|
| Flight Mode | Heli Sto Gov |
| Brake Type | Disabled |
| Brake Force | 0 |
| Cutoff Type | Soft Cutoff |
| Number of Lipo Cells | Auto Calc. |
| Cutoff Voltage | 3.0V |
| BEC Voltage | 7.4V |
| Startup Time | Soft |
| Timing | 5 |
| Motor Rotation | CW |
| Freewheel Mode | Enabled |
| Governor Gain | Level 1 |
| AutoRestart Time | 45s |
| Restart accl | 1.5s |
| Thrust Rev | Ch 8 |

Smart Technology Telemetry

Avian ESCs paired with the FC6350HX flight controller and the 4651T receiver enables the use of Smart technology. This system can provide a variety of real-time power system related telemetry data while you fly, including motor RPM, current, battery voltage and more to compatible Spektrum AirWare™ equipped transmitters.

During binding your transmitter will perform an auto configuration which will populate the telemetry page. You may need to change the telemetry values to suit this aircraft and your needs.

To enter the telemetry values:

(For iX series transmitters, you must select **Save** on each page)

- Power on your transmitter.
- Enable throttle hold on.
- Power on the aircraft and allow it to initialize.
- In your transmitter, go to the **Function List (Model Setup** in iX series transmitters).
- Select the **Telemetry** menu option.
- Go to the **Smart Battery** menu option.
- Scroll down to Startup Volts, enter **4.0V/cell**.
- Return to the **Telemetry** menu.
- Go to the **Smart ESC** menu option.
- Scroll down to **Total Cells**, enter **12**.
- Scroll down to **Low Voltage Alarm**, enter **3.4V/cell**.
- Scroll down to **Poles**, enter **10**.
- Scroll down to **Ratio**, enter **9.33:1** for 12 tooth pinion, or **10.18:1** for 11 tooth pinion
- Return to the main screen.

Rotorhead speed in excess of 2,050rpm is not recommended.

Collective Pitch Range

Normal, -12 degrees to +12 degrees
(adjust to suit your preferences)

| Telemetry Alarms | |
|---|---------|
| Smart Battery : Startup Voltage Minimum | 4.0V |
| Smart ESC : Total Cells | 12 |
| Smart ESC : Low Voltage Alarm | 3.4V |
| Smart ESC : Motor Poles | 10 |
| Smart ESC : Ratio (11 tooth pinion) | 10.18:1 |
| Smart ESC : Ratio (12 tooth pinion) | 9.33:1 |

Flight Guidelines and Warnings

- Always keep aircraft in sight and under control.
- Always keep people and pets at least 45 feet (13 meters) away when the battery is connected.
- Keep children out of the vicinity of this product at all times.
- Always turn on throttle hold prior to a rotor strike.
- Always use fully charged batteries.
- Always keep transmitter powered on while the aircraft is powered on.
- Always remove batteries before disassembly.
- Always keep moving parts clean.
- Always keep parts dry.
- Always let parts cool after use before touching.
- Always remove batteries after use.
- Always have a first aid kit with you.
- Always have an appropriate fire extinguisher with you.
- Never operate aircraft with damaged wiring.
- Never touch moving parts.

Flying Your Fusion 700

 **WARNING:** Only use Blade Fusion 700 approved carbon fiber main blades. Do not use wooden main blades with the Blade Fusion 700. Using wooden main blades may cause injury or property damage.

 **CAUTION:** The Blade Fusion 550 is intended for pilots with experience flying aerobatic, collective pitch helicopters. The Blade Fusion 700 is more responsive than other Blade helicopters. If you are not an experienced 3D or collective pitch helicopter pilot, do not attempt to fly this product.

NOTICE: To minimize damage, always activate throttle hold prior to or during a crash.

Consult local laws and ordinances before choosing a location to fly your aircraft.

Select a large, open area away from people and objects. Your first flights should be outdoors in low-wind conditions. Always stay at least 45 feet (13 meters) away from the helicopter when it is flying.

Do not attempt to fly the Blade Fusion 700 indoors.

Preflight Checklist

- Inspect the model, wiring, and electrical components.
- Activate **Normal Flight Mode** on the transmitter.
- Activate **Throttle Hold** on the transmitter. Lower the throttle to stop or idle.
- Power ON the transmitter.
- Power ON the model, and wait for initialization to complete.
- Complete the tailrotor and cyclic tests.
- Connect the flight pack to the ESC.
- Verify that all connected remote receivers display a solid orange LED.
- Confirm that the transmitter roll, pitch, yaw and collective inputs correspond to the helicopter controls.
- Confirm that the FC6350HX is compensating in the correct direction.
- Review all operational instructions before flying your model.
- Place the model on a level surface for take off.

Postflight Checklist

- Disconnect the flight battery
- Power down the FC6350HX
- Always turn the transmitter off last

Blade Tracking

 **WARNING:** Always maintain a safe distance of at least 13 meters (45 feet) when checking the main rotor blade tracking.

 **WARNING:** Always wear protective safety glasses when checking the main rotor blade tracking.

To check the blade tracking:

1. Put the helicopter in a hover at a safe distance.
2. Ensure both blades are tracking in the same plane.
3. If one blade tip appears to be higher than the other, land the helicopter, disconnect the flight battery and adjust the blade linkage.

IMPORTANT: We recommend leaving one linkage a fixed length and adjusting the opposite linkage to set blade tracking. Mark one linkage with a silver permanent marker or a dab of white paint so you know which linkage to adjust.

4. Repeat Steps 1 through 3 until both blades are moving in the same plane.

Post-Flight Inspection and Maintenance

WARNING: Disconnect and remove the flight battery prior to performing any troubleshooting or maintenance. Failure to do so may cause serious injury if the motor starts unexpectedly or if the battery or ESC connections are shorted.

| | |
|--------------------------|--|
| Ball Links | Make sure the plastic ball link holds the control ball, but is not tight (binding) on the ball. When a link is too loose on the ball, it can separate from the ball during flight and cause a crash. Replace worn ball links before they fail. |
| Cleaning | Make sure the battery is not connected before cleaning. Remove dust and debris with a soft brush or a dry lint-free cloth. |
| Bearings | Replace bearings when they become notchy (sticky in places when turning) or draggy. |
| Wiring | Make sure wiring does not block moving parts. Replace damaged wiring and loose connectors. |
| Fasteners | Make sure there are no loose screws, other fasteners or connectors. Do not over tighten metal screws in plastic parts. Tighten screws so parts are mated together, then turn screw only 1/8th of a turn more. |
| Rotors | Make sure there is no damage to rotor blades and other parts which move at high speed. Damage to these parts includes cracks, burrs, chips or scratches. Replace damaged parts before flying. |
| Flight Controller | Make sure the flight controller is securely attached to the frame. Replace the double-sided tape when necessary. The helicopter will crash if the flight controller separates from the helicopter frame. |
| Gear | Make sure the gears are all in good condition. Watch for chipped teeth or excessive wear. Dust around gears is an indication of excess wear. Replace damaged gears before flying. |

Cleaning fasteners for reuse when using thread lock

When you remove a metal fastener that was threading into metal, it needs to be cleaned before reuse. Use a cleaning solution to ensure debris from the old thread lock is fully removed. Cleaning products with a spray tube can be helpful to clean the threaded hole where access is difficult. Allow fasteners to fully dry before applying fresh thread lock for re-assembly.

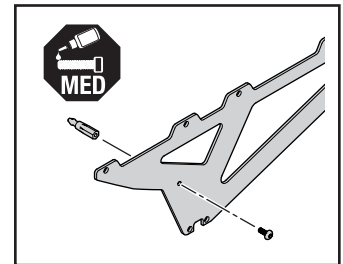

How to remove blade grip bearings

Blade grip bearings have close tolerances and require heat for removal.

1. In the event you need to service or replace your blade grip bearings, begin by disassembling your rotor head.
2. Use a heat gun (HAN100) to evenly heat the blade grips.

WARNING: Use heat protective gloves and a heat resistant surface to handle the parts during bearing removal. Failure to use PPE may result in personal injury.

3. Using heat protective gloves, pick up the blade grip and tap a heat resistant surface with the grip side down. If the grips are warm enough the bearings will come out with a few taps.
4. If the bearings do not come out easily, apply more heat and try again.

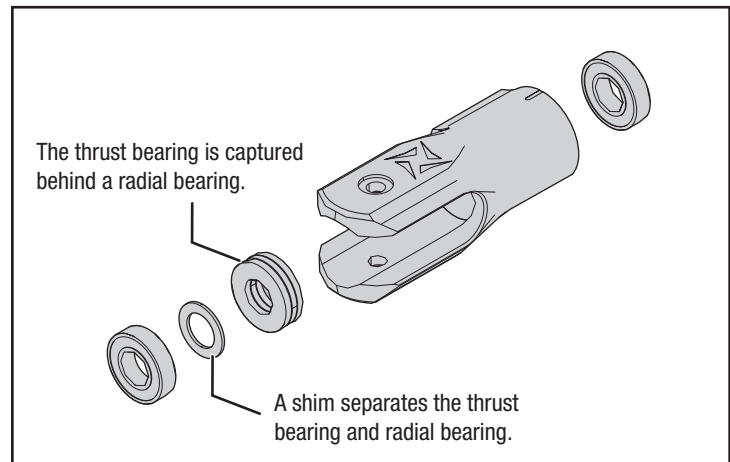

How to grease thrust bearings

Thrust bearings should be greased every 100 flights to ensure they are well lubricated.

Remove the blade grip bearings and liberally apply a quality grease to the ball races, then reassemble. Ensure the thrust bearings get re-assembled in the correct order; the outer race has a smaller ID and the inner race has a larger ID.

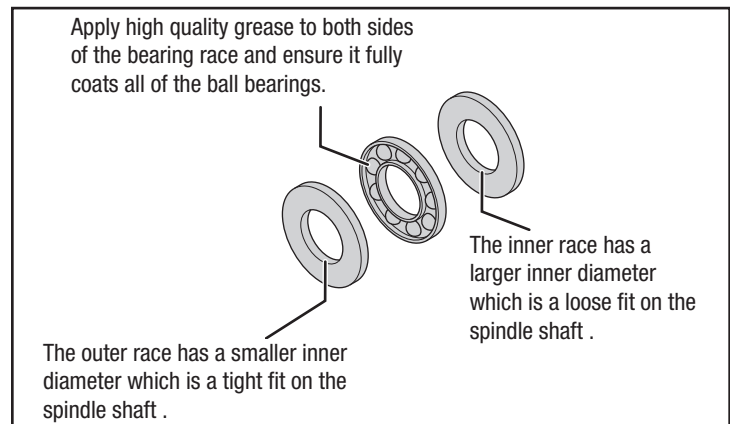

Troubleshooting Guide

| Problem | Possible Cause | Solution |
|--|---|---|
| Helicopter power is lacking | Flight battery has low voltage | Fully charge the flight battery |
| | Flight battery is old or damaged | Replace the flight battery |
| | Flight battery cells are unbalanced | Fully charge the flight battery, allowing the charger time to balance the cells |
| Helicopter will not lift off | Transmitter settings are not correct | Check throttle and pitch curve settings and pitch control direction |
| | Flight battery has low voltage | Fully charge the flight battery |
| | Main rotor blades are installed backwards | Install the main rotor blades with the thicker side as the leading edge |
| The helicopter tail spins out of control | Rudder control and/or sensor direction reversed | Make sure the rudder control and the rudder sensor are operating in the correct direction |
| | Tail servo is damaged | Check the rudder servo for damage and replace if necessary |
| | Tail drive gears are damaged | Replace damaged gears. |
| | Inadequate control arm throw | Check the rudder control arm for adequate travel and adjust if necessary |
| The helicopter wobbles in flight | Cyclic gain is too high | Decrease gain on the flight controller |
| | Head speed is too low | Increase the helicopter's head speed via your transmitter settings and/or using a freshly charged flight pack |

Limited Warranty

What this Warranty Covers

Horizon Hobby, LLC, (Horizon) warrants to the original purchaser that the product purchased (the "Product") will be free from defects in materials and workmanship at the date of purchase.

What is Not Covered

This warranty is not transferable and does not cover (i) cosmetic damage, (ii) damage due to acts of God, accident, misuse, abuse, negligence, commercial use, or due to improper use, installation, operation or maintenance, (iii) modification of or to any part of the Product, (iv) attempted service by anyone other than a Horizon Hobby authorized service center, (v) Product not purchased from an authorized Horizon dealer, (vi) Product not compliant with applicable technical regulations, or (vii) use that violates any applicable laws, rules, or regulations.

OTHER THAN THE EXPRESS WARRANTY ABOVE, HORIZON MAKES NO OTHER WARRANTY OR REPRESENTATION, AND HEREBY DISCLAIMS ANY AND ALL IMPLIED WARRANTIES, INCLUDING, WITHOUT LIMITATION, THE IMPLIED WARRANTIES OF NON-INFRINGEMENT, MERCHANTABILITY AND FITNESS FOR A PARTICULAR PURPOSE. THE PURCHASER ACKNOWLEDGES THAT THEY ALONE HAVE DETERMINED THAT THE PRODUCT WILL SUITABLY MEET THE REQUIREMENTS OF THE PURCHASER'S INTENDED USE.

Purchaser's Remedy

Horizon's sole obligation and purchaser's sole and exclusive remedy shall be that Horizon will, at its option, either (i) service, or (ii) replace, any Product determined by Horizon to be defective. Horizon reserves the right to inspect any and all Product(s) involved in a warranty claim. Service or replacement decisions are at the sole discretion of Horizon. Proof of purchase is required for all warranty claims. SERVICE OR REPLACEMENT AS PROVIDED UNDER THIS WARRANTY IS THE PURCHASER'S SOLE AND EXCLUSIVE REMEDY.

Limitation of Liability

HORIZON SHALL NOT BE LIABLE FOR SPECIAL, INDIRECT, INCIDENTAL OR CONSEQUENTIAL DAMAGES, LOSS OF PROFITS OR PRODUCTION OR COMMERCIAL LOSS IN ANY WAY, REGARDLESS OF WHETHER SUCH CLAIM IS BASED IN CONTRACT, WARRANTY, TORT, NEGLIGENCE, STRICT LIABILITY OR ANY OTHER THEORY OF LIABILITY, EVEN IF HORIZON HAS BEEN ADVISED OF THE POSSIBILITY OF SUCH DAMAGES. Further, in no event shall the liability of Horizon exceed the individual price of the Product on which liability is asserted. As Horizon has no control over use, setup, final assembly, modification or misuse, no liability shall be assumed nor accepted for any resulting damage or injury. By the act of use, setup or assembly, the user accepts all resulting liability. If you as the purchaser or user are not prepared to accept the liability associated with the use of the Product, purchaser is advised to return the Product immediately in new and unused condition to the place of purchase.

Law

These terms are governed by Illinois law (without regard to conflict of law principals). This warranty gives you specific legal rights, and you may also have other rights which vary from state to state. Horizon reserves the right to change or modify this warranty at any time without notice.

WARRANTY SERVICES

Questions, Assistance, and Services

Your local hobby store and/or place of purchase cannot provide warranty support or service. Once assembly, setup or use of the Product has been started, you must contact your local distributor or Horizon directly. This will enable Horizon to better answer your questions and service you in the event that you may need any assistance. For questions or assistance, please visit our website at www.horizonhobby.com, submit a Product Support Inquiry, or call the toll free telephone number referenced in the Warranty and Service Contact Information section to speak with a Product Support representative.

Inspection or Services

If this Product needs to be inspected or serviced and is compliant in the country you live and use the Product in, please use the Horizon Online Service Request submission process found on our website or call Horizon to obtain a Return Merchandise Authorization (RMA) number. Pack the Product securely using a shipping carton. Please note that original boxes may be included, but are not designed to withstand the rigors of shipping without additional protection. Ship via a carrier that provides tracking and insurance for lost or damaged parcels, as Horizon is not responsible for merchandise until it arrives and is accepted at our facility. An Online Service Request is available at http://www.horizonhobby.com/content/service-center_render-service-center. If you do not have internet access, please contact Horizon Product Support to obtain a RMA number along with instructions for submitting your product for service. When calling Horizon, you will be asked to provide your complete name, street address, email address and phone number where you can be reached during business hours. When sending product into Horizon, please include your RMA number, a list of the included items, and a brief summary of the problem. A copy of your original sales receipt must be included for warranty consideration. Be sure your name, address, and RMA number are clearly written on the outside of the shipping carton.

NOTICE: Do not ship LiPo batteries to Horizon. If you have any issue with a LiPo battery, please contact the appropriate Horizon Product Support office.

Warranty Requirements

For Warranty consideration, you must include your original sales receipt verifying the proof-of-purchase date. Provided warranty conditions have been met, your Product will be serviced or replaced free of charge. Service or replacement decisions are at the sole discretion of Horizon.

Non-Warranty Service

Should your service not be covered by warranty, service will be completed and payment will be required without notification or estimate of the expense unless the expense exceeds 50% of the retail purchase cost. By submitting the item for service you are agreeing to payment of the service without notification. Service estimates are available upon request. You must include this request with your item submitted for service. Non-warranty service estimates will be billed a minimum of ½ hour of labor. In addition you will be billed for return freight. Horizon accepts money orders and cashier's checks, as well as Visa, MasterCard, American Express, and Discover cards. By submitting any item to Horizon for service, you are agreeing to Horizon's Terms and Conditions found on our website http://www.horizonhobby.com/content/service-center_render-service-center.

ATTENTION: Horizon service is limited to Product compliant in the country of use and ownership. If received, a non-compliant Product will not be serviced. Further, the sender will be responsible for arranging return shipment of the un-serviced Product, through a carrier of the sender's choice and at the sender's expense. Horizon will hold non-compliant Product for a period of 60 days from notification, after which it will be discarded.

10/15

Important Federal Aviation Administration (FAA) Information

Use the QR code below to learn more about the Recreational UAS Safety Test (TRUST), as was introduced by the 2018 FAA Reauthorization Bill. This free test is required by the FAA for all recreational flyers in the United States. The completed certificate must be presented upon request by any FAA or law enforcement official.



If your model aircraft weights more than .55lbs or 250 grams, you are required by the FAA to register as a recreational flyer and apply your registration number to the outside of your aircraft. To learn more about registering with the FAA, use the QR code below.



According to FAA regulation, all unmanned aircraft flying in United States airspace are required to either fly within an FAA-Recognized Identification Area (FRIA) or continually transmit an FAA-registered remote identification from a Remote ID broadcast module, such as the Spektrum™ Sky™ Remote ID module (SPMA9500). Use the QR code to learn more about the FAA Remote ID regulations.



Warranty and Service Contact Information

| Country of Purchase | Horizon Hobby | Contact Information | Address |
|--------------------------|---|--|---|
| United States of America | Horizon Service Center (Repairs and Repair Requests) | servicecenter.horizonhobby.com/RequestForm/ | 1608 Interstate Drive Champaign, IL 61822 |
| | Horizon Product Support (Product Technical Assistance) | productsupport@horizonhobby.com 800-338-4639 | |
| | Sales | websales@horizonhobby.com 800-338-4639 | |
| European Union | Horizon Technischer Service | service@horizonhobby.eu | Hanskampring 9 D 22885 Barsbüttel, Germany |
| | Sales: Horizon Hobby GmbH | +49 (0) 4121 2655 100 | |

FCC Compliance Information

FC This equipment complies with FCC and IC radiation exposure limits set forth for an uncontrolled environment. This equipment should be installed and operated with minimum distance 20cm between the radiator and/or antenna and your body (excluding fingers, hands, wrists, ankles and feet). This transmitter must not be co-located or operating in conjunction with any other antenna or transmitter.

Supplier's Declaration of Conformity

This device complies with part 15 of the FCC Rules. Operation is subject to the following two conditions: (1) This device may not cause harmful interference, and (2) this device must accept any interference received, including interference that may cause undesired operation.

 **CAUTION:** Changes or modifications not expressly approved by the party responsible for compliance could void the user's authority to operate the equipment.

NOTE: This equipment has been tested and found to comply with the limits for a Class B digital device, pursuant to part 15 of the FCC Rules. These limits are designed to provide reasonable protection against harmful interference in a residential installation. This equipment generates, uses and can radiate radio frequency energy and, if not installed and used in accordance with the instructions, may cause harmful interference to radio communications. However, there is no guarantee that interference will not occur in a particular installation. If this equipment does cause harmful interference to radio or television reception, which can be determined by turning the equipment off and on, the user is encouraged to try to correct the interference by one or more of the following measures:

- Reorient or relocate the receiving antenna.
- Increase the separation between the equipment and receiver.
- Connect the equipment into an outlet on a circuit different from that to which the receiver is connected.
- Consult the dealer or an experienced radio/TV technician for help.

Horizon Hobby, LLC
2904 Research Rd., Champaign, IL 61822
Email: compliance@horizonhobby.com
Web: HorizonHobby.com

IC Compliance Information

CAN ICES-3 (B)/NMB-3(B)

This device contains license-exempt transmitter(s)/receiver(s) that comply with Innovation, Science, and Economic Development Canada's license-exempt RSS(s). Operation is subject to the following 2 conditions:

1. This device may not cause interference.
2. This device must accept any interference, including interference that may cause undesired operation of the device.

Compliance Information for the European Union

CE EU Compliance Statement:

Blade Fusion 700 (BLH13075): Hereby, Horizon Hobby, LLC declares that the device is in compliance with the following: EU Radio Equipment Directive 2014/53/EU; RoHS 2 Directive 2011/65/EU; RoHS 3 Directive - Amending 2011/65/EU Annex II 2015/863.

The full text of the EU declaration of conformity is available at the following internet address: <https://www.horizonhobby.com/content/support-render-compliance>.

NOTE: This product contains batteries that are covered under the 2006/66/EC European Directive, which cannot be disposed of with normal household waste. Please follow local regulations.

EU Manufacturer of Record:

Horizon Hobby, LLC
2904 Research Road
Champaign, IL 61822 USA

EU Importer of Record:

Horizon Hobby, GmbH
Hanskampring 9
22885 Barsbüttel Germany

WEEE NOTICE:



This appliance is labeled in accordance with European Directive 2012/19/EU concerning waste of electrical and electronic equipment (WEEE). This label indicates that this product should not be disposed of with household waste. It should be deposited at an appropriate facility to enable recovery and recycling.



Exploded View / Explosionszeichnung / Vue éclatée / Vista esplosa

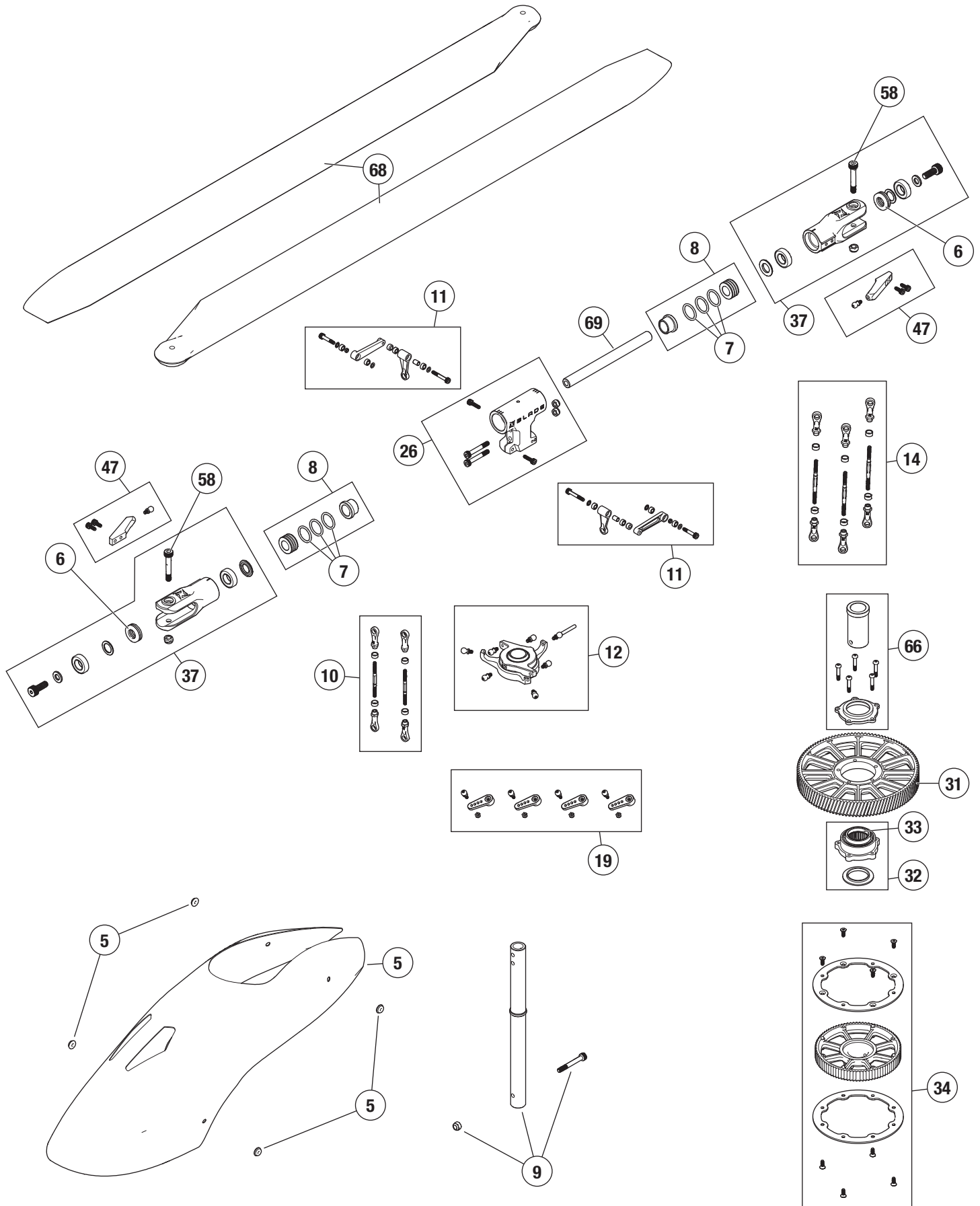

Exploded View / Explosionszeichnung / Vue éclatée / Vista esplosa

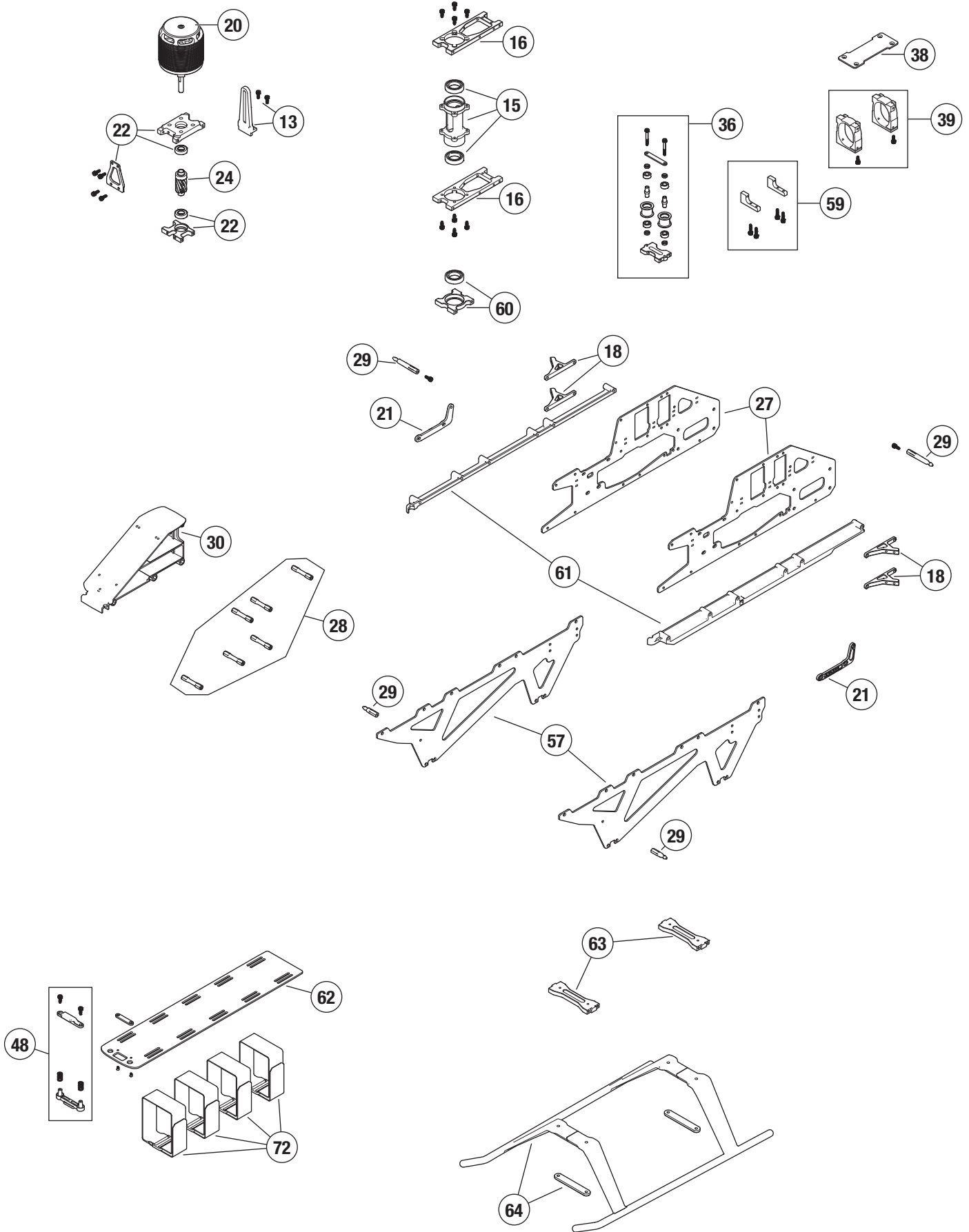

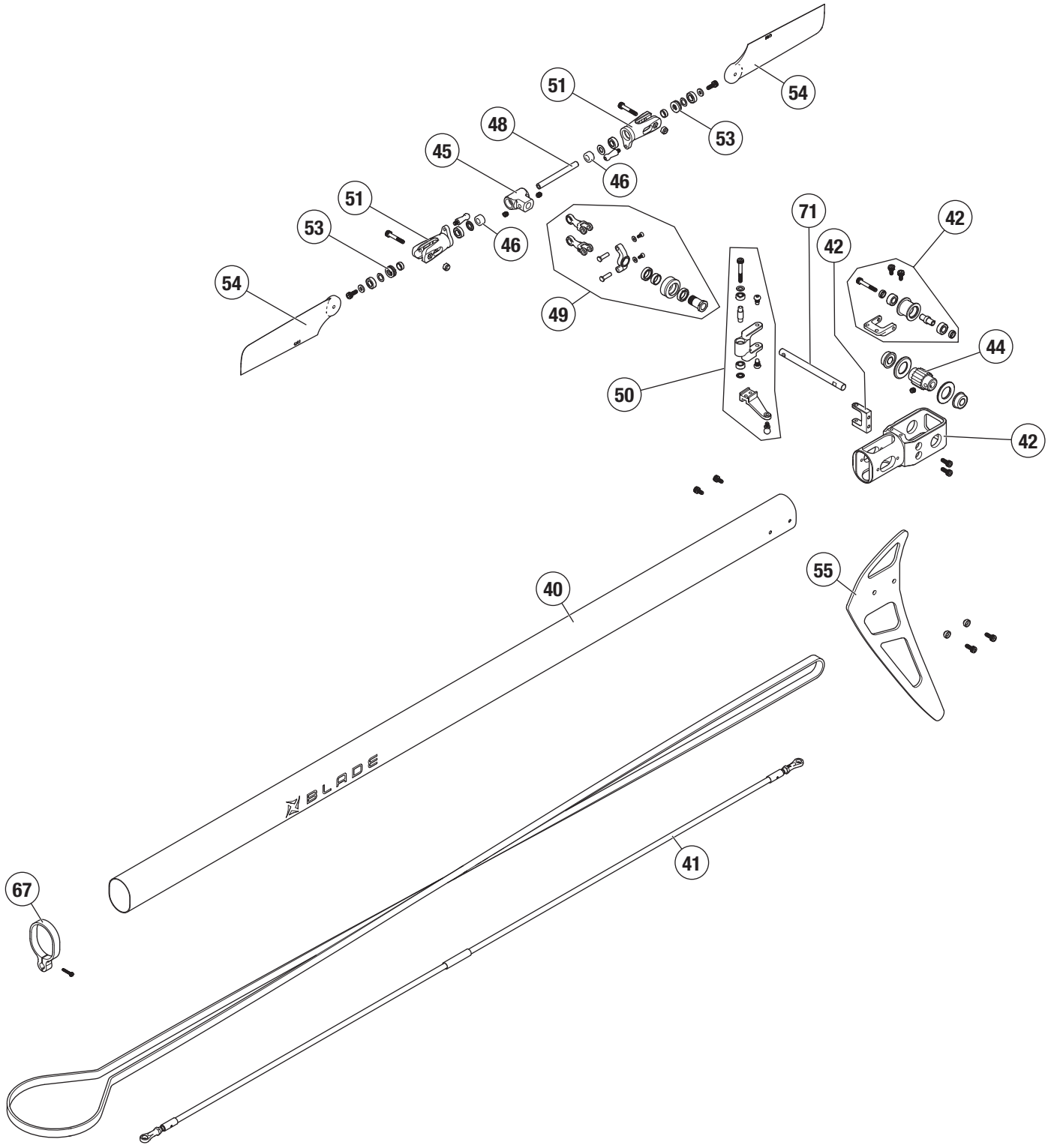

Parts List / Ersatzteile / Pièces de rechange / Pezzi di ricambio

| # | Part # | English | Deutsch | Français | Italiano |
|----|---------------|--|---|--|---|
| 1 | SPMSH6350 | H6350 Ultra Torque High Speed Heli Cyclic HV Servo | H6350 Servo mit Ultra-Drehmoment, Hochgeschwindigkeits-Steuerservo HV | Servo cyclique HV à couple et vitesse élevés pour hélicoptère H6350 | H6350 Servo HV ciclico heli ultra coppia alta velocità |
| 2 | SPMSH6360 | H6360 Mid Torque Ultra Speed Heli Tail HV Servo | H6360 Hochgeschwindigkeits-Heli-Heckservo HV mit mittlerem Drehmoment | Servo d'empennage HV à vitesse élevée et couple moyen pour hélicoptère H6360 | H6360 Servo HV coda heli media coppia media ultraveloce |
| 3 | SPMXAE-1200HV | Avian 200A HV Smart Brushless ESC 6S-14S | Avian 200A HV bürstenloser Smart-Geschwindigkeitsregler 6S-14S | Variateur ESC sans balais Avian 200A HV 6S-14S | ECS Avian 200A HV Smart Brushless 6S-14S |
| 4 | SPM9745 | DSMX Remote Receiver | DSMX Funkempfänger | Récepteur à distance DSMX | Ricevitore remoto DSMX |
| 5 | BLH-1662 | Painted Canopy: Fusion 700 | Lackierte Kanzel: Fusion 700 | Verrière peinte : Fusion 700 | Capottina verniciata: Fusion 700 |
| 6 | BLH-1663 | Thrust bearing Set, Main: Fusion 700 | Axiallagersatz, Haupt: Fusion 700 | Ensemble de paliers de butée, Principal : Fusion 700 | Set cuscinetti reggispinta, principale: Fusion 700 |
| 7 | BLH-1701 | Damper "o" ring set: Fusion 700 | Satz O-Ringe für Dämpfer: Fusion 700 | Ensemble de joints toriques d'amortisseur : Fusion 700 | Set O ring smorzatore: Fusion 700 |
| 8 | BLH-1708 | Damper set: Fusion 700 | Dämpfersatz: Fusion 700 | Ensemble d'amortisseurs : Fusion 700 | Set smorzatori: Fusion 700 |
| 9 | BLH-1724 | Main Shaft: Fusion 700 | Hauptwelle: Fusion 700 | Arbre principal : Fusion 700 | Albero principale: Fusion 700 |
| 10 | BLH-1710 | Rotor head linkage set: Fusion 700 | Rotorkopf-Gestängesatz: Fusion 700 | Ensemble de tringlerie de la tête du rotor : Fusion 700 | Set leveraggi testa rotore: Fusion 700 |
| 11 | BLH-1725 | Follower arm: Fusion 700 | Folgerarm: Fusion 700 | Bras suiveur : Fusion 700 | Braccio elevatore: Fusion 700 |
| 12 | BLH-1665 | Swashplate: Fusion 700 | Taumelscheibe: Fusion 700 | Plateau oscillant : Fusion 700 | Piatto oscillante: Fusion 700 |
| 13 | BLH-1702 | Anti-rotation bracket: Fusion 700 | Anti-Rotationshalterung: Fusion 700 | Support antirotation : Fusion 700 | Staffa antirotazione: Fusion 700 |
| 14 | BLH-1707 | Swashplate linkage set: Fusion 700 | Gestängesatz Taumelscheibe: Fusion 700 | Ensemble de tringlerie de plateau cyclique : Fusion 700 | Set leveraggi piatto ciclico: Fusion 700 |
| 15 | BLH-1721 | Main Bearing Block: Fusion 700 | Hauptlagerbock: Fusion 700 | Support de bloc de palier principal : Fusion 700 | Blocco cuscinetto principale: Fusion 700 |
| 16 | BLH-1679 | Bearing Block Support: Fusion 700 | Lagerblockhalterung: Fusion 700 | Support de bloc de palier : Fusion 700 | Supporto blocco cuscinetto: Fusion 700 |
| 17 | BLH-1704 | Ball Bearing 15 X 24 X 5 | Kugellager 15 X 24 X 5 | Roulement à billes 15 x 24 x 5 | Cuscinetto a sfera 15 x 24 x 5 |
| 18 | BLH-1695 | Cyclic Servo Mount: Fusion 700 | Steuerservohalterung: Fusion 700 | Support de servo cyclique : Fusion 700 | Supporto servo ciclico: Fusion 700 |
| 19 | BLH-1728 | Aluminum servo horn set: Fusion 700 | Aluminium-Servohorn-Satz: Fusion 700 | Ensemble de renvois de commande de servo : Fusion 700 | Set squadretta servo alluminio: Fusion 700 |
| 20 | SPMX-1079 | 4735 540kv Brushless motor | 4735 540kv bürstenloser Motor | Moteur sans balai 4735 540 Kv | Motore Brushless 4735 540 Kv |
| 21 | BLH-1672 | Motor mount frame stiffener: Fusion 700 | Rahmenversteifung Motorhalterung: Fusion 700 | Raidisseur de cadre pour le support du moteur : Fusion 700 | Rinforzo telaio supporto motore: Fusion 700 |
| 22 | BLH-1715 | Motor mount set: Fusion 700 | Motorhalterungssatz: Fusion 700 | Ensemble support du moteur : Fusion 700 | Set supporto motore: Fusion 700 |
| 23 | BLH-1692 | Ball Bearing m8 X 16 X 4 | Kugellager m8 X 16 X 4 | Roulement à billes m8 X 16 X 4 | Cuscinetto a sfera m8 x 16 x 4 |
| 24 | BLH-1667 | Pinion Gear 11 Tooth: Fusion 700 | Ritzel 11 Zähne: Fusion 700 | Engrenage à pignons 11 dents : Fusion 700 | Pignone 11 denti: Fusion 700 |
| 25 | BLH-1671 | Pinion gear 12 tooth: Fusion 700 | Ritzel 12 Zähne: Fusion 700 | Engrenage à pignons 12 dents : Fusion 700 | Pignone 12 denti: Fusion 700 |
| 26 | BLH-1661 | Main Rotor Hub: Fusion 700 | Hauptrotornabe: Fusion 700 | Moyeu du rotor principal : Fusion 700 | Mozzo rotore principale: Fusion 700 |
| 27 | BLH-1718 | Carbon fiber upper frame: Fusion 700 | Oberer Carbonfaser-Rahmen: Fusion 700 | Châssis principal en fibre de carbone : Fusion 700 | Telaio superiore fibra di carbonio: Fusion 700 |
| 28 | BLH-1706 | Aluminum frame spacer: Fusion 700 | Abstandshalter Aluminiumrahmen: Fusion 700 | Entretoise de cadre en aluminium : Fusion 700 | Distanziale telaio alluminio: Fusion 700 |
| 29 | BLH-1711 | Canopy mount set: Fusion 700 | Kanzel-Montagesatz: Fusion 700 | Ensemble de support de verrière : Fusion 700 | Set supporti capottina: Fusion 700 |
| 30 | BLH-1684 | ESC Tray: Fusion 700 | Trägerplatte Geschwindigkeitsregler: Fusion 700 | Plateau de variateur ESC : Fusion 700 | Vassoio ESC: Fusion 700 |
| 31 | BLH-1703 | Machined Main Gear 112t: Fusion 700 | Gefrästes Hauptgetriebe 112t: Fusion 700 | Engrenage principal usiné 112 dents : Fusion 700 | Ingranaggio principale lavorato 112T: Fusion 700 |
| 32 | BLH-1666 | Auto rotation hub assembly: Fusion 700 | Automatisch drehende Nabenbaugruppe: Fusion 700 | Assemblage du moyeu à rotation automatique : Fusion 700 | Gruppo mozzo autorotazione: Fusion 700 |
| 33 | BLH-1685 | Sprague clutch: Fusion 700 | Sprague-Kupplung: Fusion 700 | Embrayage Sprague : Fusion 700 | Frizione Sprague: Fusion 700 |

| # | Part # | English | Deutsch | Français | Italiano |
|----|----------|---|---|--|---|
| 34 | BLH-1691 | Tail Rotor Pulley 88t: Fusion 700 | Heckrotor-Riemenscheibe 88t: Fusion 700 | Poulie de rotor d'empennage 88 dents : Fusion 700 | Puleggia rotore di coda 88T: Fusion 700 |
| 35 | BLH-1722 | Tail rotor drive belt: Fusion 700 | Heckrotor-Antriebsriemen: Fusion 700 | Courroie d'entraînement de rotor d'empennage : Fusion 700 | Cinghia di trasmissione coda: Fusion 700 |
| 36 | BLH-1689 | Tail drive belt alignment guide set: Fusion 700 | Ausrichthilfe für Heckantrieb: Fusion 700 | Ensemble de guides d'alignement de la courroie d'entraînement d'empennage : Fusion 700 | Set guide allineamento cinghia di trasmissione coda: Fusion 700 |
| 37 | BLH-1682 | Main Rotor Blade Grip: Fusion 700 | Blatthalter Hauptrotor:satz: Fusion 700 | Poignée de la pale principale du rotor : Fusion 700 | Portapale rotore principale: Fusion 700 |
| 38 | BLH-1690 | Carbon fiber FC mounting tray: Fusion 700 | FC Carbon-Halterung: Fusion 700 | Plateau de montage FC en fibre de carbone : Fusion 700 | Vassoio montaggio FC fibra carbonio: Fusion 700 |
| 39 | BLH-1696 | Tail boom clamp: Fusion 700 | Heckauslegerklemme: Fusion 700 | Pince de poutre de queue : Fusion 700 | Morsetto trave di coda: Fusion 700 |
| 40 | BLH-1688 | Aluminum tail boom: Fusion 700 | Aluminium-Heckausleger: Fusion 700 | Poutre de queue en aluminium : Fusion 700 | Trave di coda in alluminio: Fusion 700 |
| 41 | BLH-1712 | Tail rotor pushrod: Fusion 700 | Heckrotorgestänge: Fusion 700 | Barre de liaison du rotor d'empennage : Fusion 700 | Tiranteria rotore di coda: Fusion 700 |
| 42 | BLH-1669 | Aluminum tail case: Fusion 700 | Aluminium-Heckgehäuse: Fusion 700 | Boîtier de queue en aluminium : Fusion 700 | Cassa di coda in alluminio: Fusion 700 |
| 43 | BLH-1668 | Ball bearing, flanged M6 X 13 X 5 | Kugellager, Flansch M6 X 13 X 5 | Roulement à billes, bridé M6 X 13 X 5 | Cuscinetto a sfere, flangiato M6 X 13 X 5 |
| 44 | BLH-1673 | Tail drive pulley 18t: Fusion 700 | Heckantriebsscheibe 18t: Fusion 700 | Poulie d'entraînement d'empennage 18 dents : Fusion 700 | Puleggia motrice coda 18T: Fusion 700 |
| 45 | BLH-1693 | Tail rotor hub: Fusion 700 | Heckrotornabe: Fusion 700 | Moyeu du rotor d'empennage : Fusion 700 | Mozzo rotore di coda: Fusion 700 |
| 46 | BLH-1714 | Tail Rotor Damper set: Fusion 700 | Heckrotor-Dämpfersatz: Fusion 700 | Jeu d'amortisseurs du rotor d'empennage : Fusion 700 | Set smorzatore rotore di coda: Fusion 700 |
| 47 | BLH-1675 | Pitch arm: Fusion 700 | Pitch-Arm: Fusion 700 | Bras d'inclinaison : Fusion 700 | Braccio passo: Fusion 700 |
| 48 | BLH-1664 | Tail spindle: Fusion 700 | Heckspindel: Fusion 700 | Axe de queue : Fusion 700 | Mandrino di coda: Fusion 700 |
| 49 | BLH-1720 | Pitch slider assembly: Fusion 700 | Schiebehülse-Baugruppe: Fusion 700 | Assemblage du curseur d'inclinaison : Fusion 700 | Gruppo cursore passo: Fusion 700 |
| 50 | BLH-1687 | Pitch slider bellcrank: Fusion 700 | Schiebehülse-Umlenkhebel: Fusion 700 | Levier de renvoi de direction du curseur d'inclinaison : Fusion 700 | Leva a squadra cursore passo: Fusion 700 |
| 51 | BLH-1719 | Tail rotor grip set: Fusion 700 | Heckrotor-Blättersatz: Fusion 700 | Ensemble de pales du rotor d'empennage : Fusion 700 | Set portapale coda: Fusion 700 |
| 52 | BLH-1676 | Ball bearing m5 X 10 X 3 | Kugellager m5 X 10 X 3 | Roulement à billes m5 X 10 X 3 | Cuscinetto a sfera m5 x 10 x 3 |
| 53 | BLH-1717 | Thrust bearing set m5 X 10 | Axiallagersatz m5 X 10 | Ensemble de paliers de butée m5 X 10 | Set cuscinetti reggispinta m5 x 10 |
| 54 | BLH-1694 | Carbon fiber tail rotor blade set 105mm | Carbon-Heckrotorblatt-Satz 105mm | Ensemble de pales de rotor d'empennage en fibre de carbone 105 mm | Set pale rotore di coda in fibra di carbonio 105 mm |
| 55 | BLH-1726 | Carbon fiber tail fin: Fusion 700 | Carbonfaser-Seitenleitwerk: Fusion 700 | Aileron d'empennage en fibre de carbone : Fusion 700 | Pinna di coda in fibra di carbonio: Fusion 700 |
| 56 | BLH-1709 | Carbon fiber tail fin un-painted: Fusion 700 (option) | Kohlefaser-Seitenleitwerk unlackiert: Fusion 700 (Option) | Aileron d'empennage en fibre de carbone non peint : Fusion 700 (option) | Pinna di coda in fibra di carbonio non verniciata: Fusion 700 (opzione) |
| 57 | BLH-1686 | Lower Carbon fiber frame: Fusion 700 | Unterer Carbon-Rahmen: Fusion 700 | Cadre inférieur en fibre de carbone : Fusion 700 | Telaio inferiore in fibra di carbonio: Fusion 700 |
| 58 | BLH-1683 | Main Rotor Blade bolts: Fusion 700 | Hauptrotorblattschrauben: Fusion 700 | Boulons des pales du rotor principal : Fusion 700 | Bulloni pale rotore principale: Fusion 700 |
| 59 | BLH-1699 | Aluminum tail servo mount: Fusion 700 | Aluminium-Heckservohalterung: Fusion 700 | Support de servo d'empennage en aluminium : Fusion 700 | Supporto servo coda alluminio: Fusion 700 |
| 60 | BLH-1727 | lower main shaft bearing block: Fusion 700 | Unterer Hauptwellen-Lagerbock: Fusion 700 | Bloc de palier d'arbre principal inférieur : Fusion 700 | Blocco cuscinetto albero principale inferiore: Fusion 700 |
| 61 | BLH-1698 | Battery tray rails: Fusion 700 | Schienen für Akkufach: Fusion 700 | Rails du support de batterie : Fusion 700 | Binari vassoio batteria: Fusion 700 |
| 62 | BLH-1705 | Carbon fiber battery tray: Fusion 700 | Carbon-Akkufach: Fusion 700 | Support de batterie en fibre de carbone : Fusion 700 | Vassoio batteria in fibra di carbonio: Fusion 700 |
| 63 | BLH-1697 | Landing gear mounts: Fusion 700 | Fahrwerkhalterungen: Fusion 700 | Supports du train d'atterrissage : Fusion 700 | Supporti carrello di atterraggio: Fusion 700 |
| 64 | BLH-1670 | Landing gear white: Fusion 700 | Fahrwerk weiß: Fusion 700 | Train d'atterrissage blanc : Fusion 700 | Carrello di atterraggio bianco: Fusion 700 |

| # | Part # | English | Deutsch | Français | Italiano |
|----|----------|---|--|---|--|
| 65 | BLH-1674 | Foam Blade Holder | Schaumstoff-Blatthalter | Porte-pales en mousse | Supporto pale in schiuma |
| 66 | BLH-1681 | Auto rotation clutch sleeve: Fusion 700 | Automatisch drehende Kupp-lungsmuffe: Fusion 700 | Manchon d'embrayage à rotation automatique : Fusion 700 | Manicotto frizione autorotazione: Fusion 700 |
| 67 | BLH-1723 | Pushrod support: Fusion 700 | Schubstangenhalterung: Fusi-on 700 | Support de la barre de liaison : Fusion 700 | Supporto asta di spinta: Fusion 700 |
| 68 | BLH-1677 | Carbon Fiber Main Rotor Blades 700mm | Carbonfaser-Hauptrotorblätter 700mm | Pales de rotor principal en fibre de carbone 700 mm | Pale rotore principale in fibra di carbonio 700 mm |
| 69 | BLH-1716 | Feathering Shaft: Fusion 700 | Federwelle: Fusion 700 | Arbre à empennage : Fusion 700 | Albero incidenza: Fusion 700 |
| 70 | BLH-1678 | Radial Ball Bearing M10x19x5 | Radial-Kugellager M10x19x5 | Roulement à billes radial M10x19x5 | Cuscinetto a sfere radiale M10x19x5 |
| 71 | BLH-1749 | Tail Shaft | Heckwelle | Arbre d'empennage | Albero coda |
| 72 | BLH-1733 | Battery Straps | Akku-Klemmen | Sangles de batterie | Fascette batterie |

Recommended Components / Empfohlene Komponenten / Composants recommandés / Componenti raccomandati

| Part # | English | Deutsch | Français | Italiano |
|-----------|--|--|---|---|
| BLH-1700 | Painted canopy (option) | Lackierte Kanzel (Option) | Verrière peinte (option) | Capottina verniciata (opzione) |
| BLH-1680 | Tail Drive Pulley 17t (option) | Heckantriebsriemenscheibe 17t (Option) | Poulie d'entraînement d'empen-nage 17 dents (option) | Puleggia motrice coda 17T (op-zione) |
| BLH-1863 | Tail Drive Pulley 14t (option) | Heckantriebsriemenscheibe 14t (Option) | Poulie d'entraînement d'empen-nage 14 dents (option) | Puleggia motrice coda 14T (op-zione) |
| BLH-2013 | Carbon Fiber Tail Rotor Blade Set 115mm (option) | Carbon Kohlefaser-Heckrotorblatt-satz 115mm (Option) | Ensemble de pales de rotor de queue en fibre de carbone 115 mm (option) | Set pale rotore di coda in fibra di carbonio 115 mm (opzione) |
| BLH-1713 | Landing Gear Black (option) | Fahrwerk Schwarz (Option) | Train d'atterrissage noir (option) | Carrello di atterraggio nero (op-zione) |
| SPMX-1085 | Brushless Motor 4730-350kv 10p(option) | Bürstenloser Motor 4730-350kv 10p (Option) | Moteur sans balais 4730-350 kv 10p (option) | Motore Brushless 4730-350 Kv 10P (opzione) |

Optional Parts / Optionale Bauteile / Pièces optionnelles / Pezzi opzionali

| Part # | English | Deutsch | Français | Italiano |
|--------------|--|--|--|--|
| SPM9745 | DSMX Remote Receiver | DSMX Funkempfänger | Récepteur à distance DSMX | Ricevitore remoto DSMX |
| SPMFC6350HX | FC6350HX Helicopter FBL System | FC6350HX Hubschrauber mit FBL-System | Système FBL pour hélicoptère FC6350HX | Sistema per elicottero FBL FC6350HX |
| SPMR8200 | NX8 8 Ch DSMX Transmitter Only | Nur NX8 8-Kanal-DSMX-Sender | Émetteur uniquement DSMX 8 canaux NX8 | NX8 8 canali DSMX solo trasmit-tente |
| SPMSH6350 | H6350 U-T / H-S Heli Cyclic Servo | H6350 U-T/H-S Heli-Steuerservo | Servo cyclique H6350 U-T / H-S Heli | Servo ciclico H6350 U-T / H-S elicottero |
| SPMSH6360 | H6360 M-T / U-S Heli servo | H6360 M-T/U-S Hubschrauber-Servo | Servo d'empennage H6360 M-T / U-S Heli | Servo elicottero H6360 M-T / U-S |
| SPMX-1091 | 5000mAh 6S 22.2V X2 100C Smart LiPo Battery: Dual IC5; | 5000mAh 6S 22.2V X2 100C Smart LiPo-Akku: Doppel-IC5; | Batterie Li-Po Smart 5000 mAh 6S 22,2 V X2 100C : Double IC5 ; | Batteria LiPo Smart 5000 mAh 6S 22,2V X2 100C: Doppio IC5; |
| SPMXAE1120HV | Avian 120 Amp Brushless Smart ESC 6S - 12S | Avian Bürstenloser 120-A-Smart-Geschwindigkeitsregler 6S - 12S | Variateur ESC Smart sans balais 120 A Avian 6S - 12S | Avian 120 A Brushless Smart ESC 6S-12S |
| SPMXAE1200HV | Avian 200A HV Smart Brushless ESC 6S-14S | Avian 200A HV bürstenloser Smart-Geschwindigkeitsregler 6S-14S | Variateur ESC sans balais Avian 200A HV 6S-14S | Avian 200A HV Smart Brushless ESC 6S-14S |
| SPMXC2010 | Smart S2200 G2 AC Charger, 2x200 | Smart S2200 G2 Wechselstrom-Ladegerät, 2x200 | Chargeur c.a. Smart S2200 G2, 2 x 200 | Caricabatterie Smart S2200 G2 AC2x200 |



©2024 Horizon Hobby, LLC.

Blade, the Blade logo, Avian, IC5, EC5, DSM, DSM2, DSMX and the Horizon Hobby logo are trademarks or registered trademarks of Horizon Hobby, LLC.

The Spektrum trademark is used with permission of Bachmann Industries, Inc.

Updated 7/24

643429.1

BLH13075, BLH13075C, BLH13075HPC