

THE ALL NEW

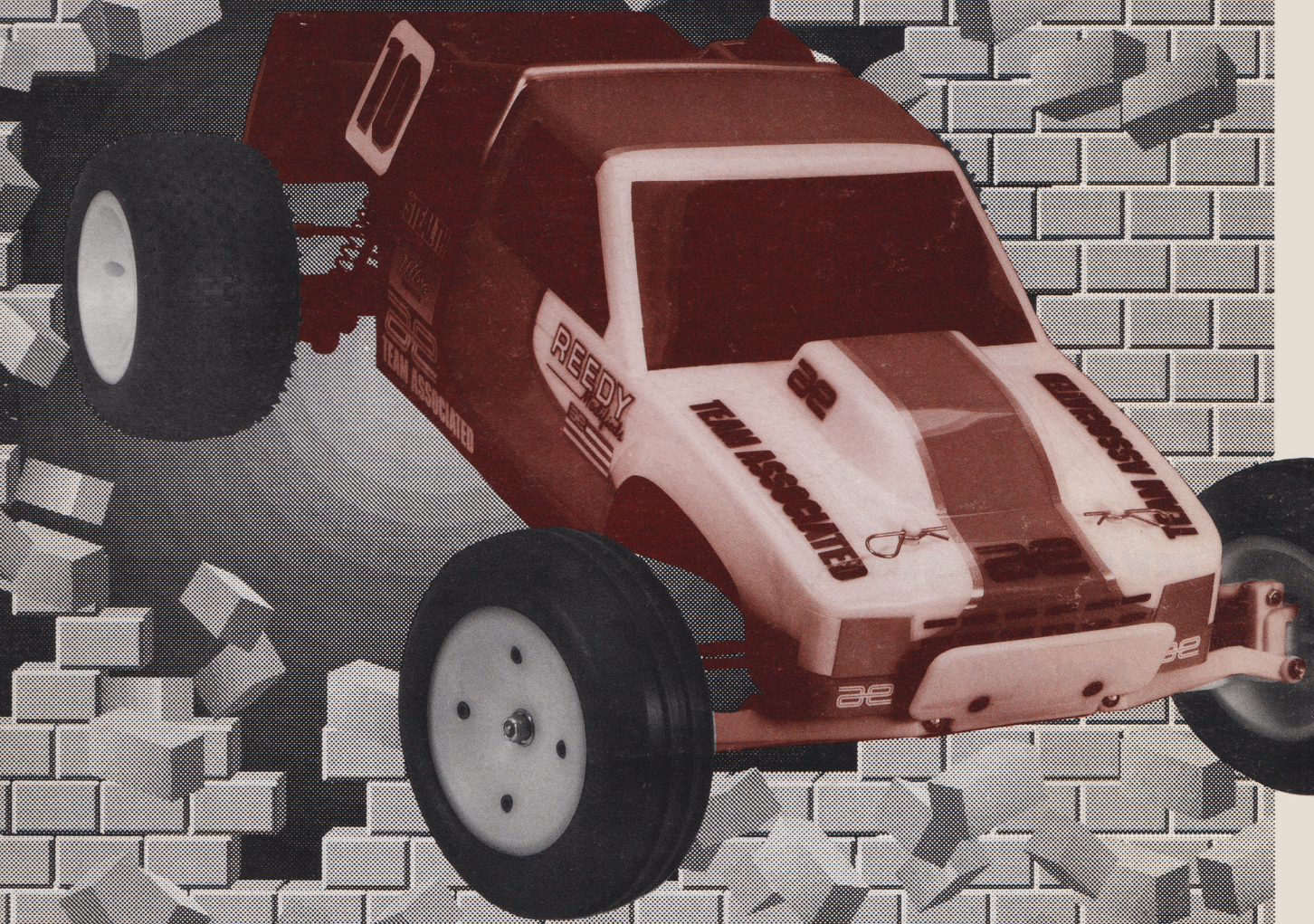

A NEW TECHNOLOGICAL BREAKTHROUGH FROM TEAM ASSOCIATED

RC10T TRUCK

INSTRUCTION MANUAL

:: Introduction

Thank you for purchasing this Team Associated product. This assembly manual contains instructions and tips for building and maintaining your new RC10T Kit. Please take a moment to read through this manual to help familiarize yourself with these steps.

We are continually changing and improving our designs; therefore, actual parts may appear slightly different than in the illustrations. New parts will be noted on supplementary sheets located in the appropriate parts bags. Check each bag for these sheets before you start to build.

:: KIT Features

Features in the RC10T Kit:

- Authentic replica of the RC10T Truck Kit originally released in 1991
- Black anodized 6061-T6 aluminum monocoque tub chassis
- Fully adjustable four wheel independent suspension
- Longer front and rear A-arms
- Long travel, fluid-filled gold anodized aluminum coil-over shocks
- Sealed 3-gear Stealth A.T.C. transmission
- High-torque ball differential
- Exceptional ground clearance with low center of gravity
- Narrow front and wide rear tires with modular racing wheels
- Clear polycarbonate stadium truck body
- Heavy-duty fiberglass shock towers
- Oilite bushings throughout
- Heavy-duty servo saver
- Fits 6-cell NIMH and 2S LiPo battery packs

:: Additional

Your new RC10T Kit comes as a kit. There are some items you will need to complete your kit (refer to website for suggestions):

- RC two channel surface frequency radio system
- Electronic Speed Control (ESC)
- Steering Servo
- 2S, 7.4V Lipo stick battery or 7.2V NiMH battery
- Battery charger compliant to battery type
- Polycarbonate specific paint
- Pinion gear, size to be determined by type and wind of motor you use
- RC Electric Motor
- Servo Horn (AE #89007)
- Thread Lock (AE #1596)

Tools included:

- Allen wrenches (.035", .050", 1/16", 3/32")
- Shock building tool

:: Other Helpful Items

- Silicone Shock Fluid (Refer to website for complete listings)
- Tire Adhesive (AE #1697)
- Shock Pliers (AE #1681)
- Wire Cutters / Hobby Knife
- Body Scissors (AE #1737)
- Green Slime shock lube (AE #1105)
- Needle Nose Pliers
- FT 7-Piece 1/4 in Hex Driver Set (AE #1650)
- Reamer / Hole Punch (AE #1499)
- Calipers or a Precision Ruler
- Soldering Iron

Associated Electrics, Inc.
21062 Bake Parkway
Lake Forest, CA 92630



Customer Service
Tel: 949.544.7500
Fax: 949.544.7501

:: Hardware - 1:1 Scale View

Cap Head (shcs)

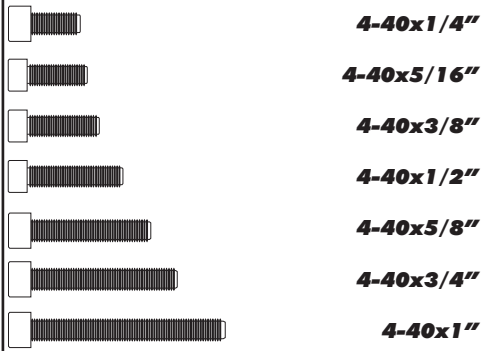

Flat Head (fhcs)

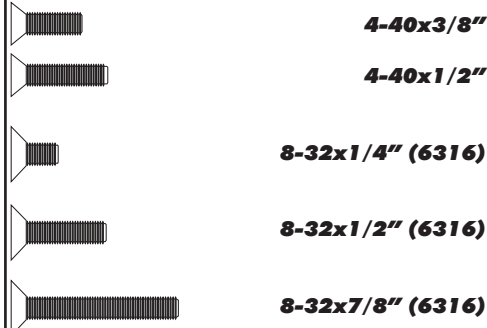

Button Head (bhcs)



Bushings

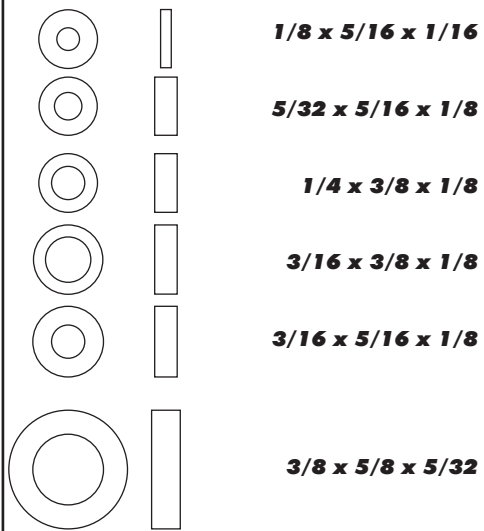

Set Screws



Nuts (lock/plain)

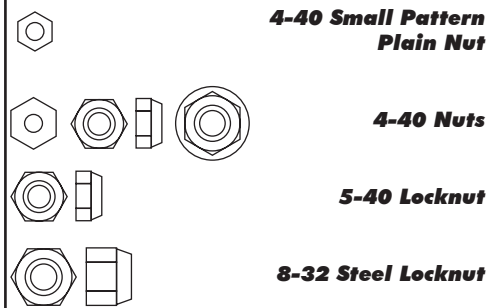

Clips



Diff Balls

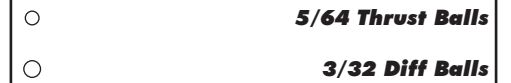

Shims and Washers

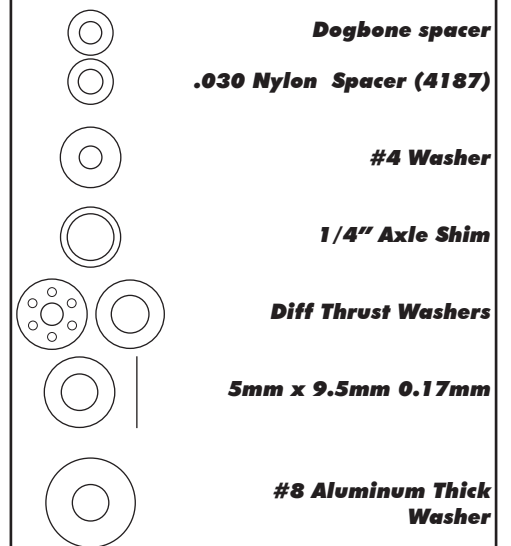

Notes:

:: Table of Contents

1..... Cover	9.....Rear End Build (Bag G / I)
2..... Introduction	12 - 13.....Turnbuckles Build (Bag F)
3.....1:1 Hardware "Fold Out"	11..... Shocks Build (Bag H)
4..... Table of Contents	13Transmission Build (Bag J / K)
5.....Servo Saver Build (Bag A)	16..... Tire Build (Bag L)
6.....Servo Saver Build (Bag A / B / I)	17..... Body Install
8..... Bumper / Body Mounts Build (Bag C / D)	18..... Back Cover
8.....Servo Build (Bag E / I)	
9.....Battery Cup Build (Bag F)	

:: Notes



This symbol indicates a special note or instruction in the manual.

There is a 1:1 hardware foldout page in the front of the manual. To check the size of a part, line up your hardware with the correct drawing until you find the exact size.

Associated Electrics, Inc.
21062 Bake Parkway
Lake Forest, CA 92630



Customer Service
Tel: 949.544.7500
Fax: 949.544.7501

:: Nose Plate / Steering Build - Bag A - Step 1

LEFT

LEFT

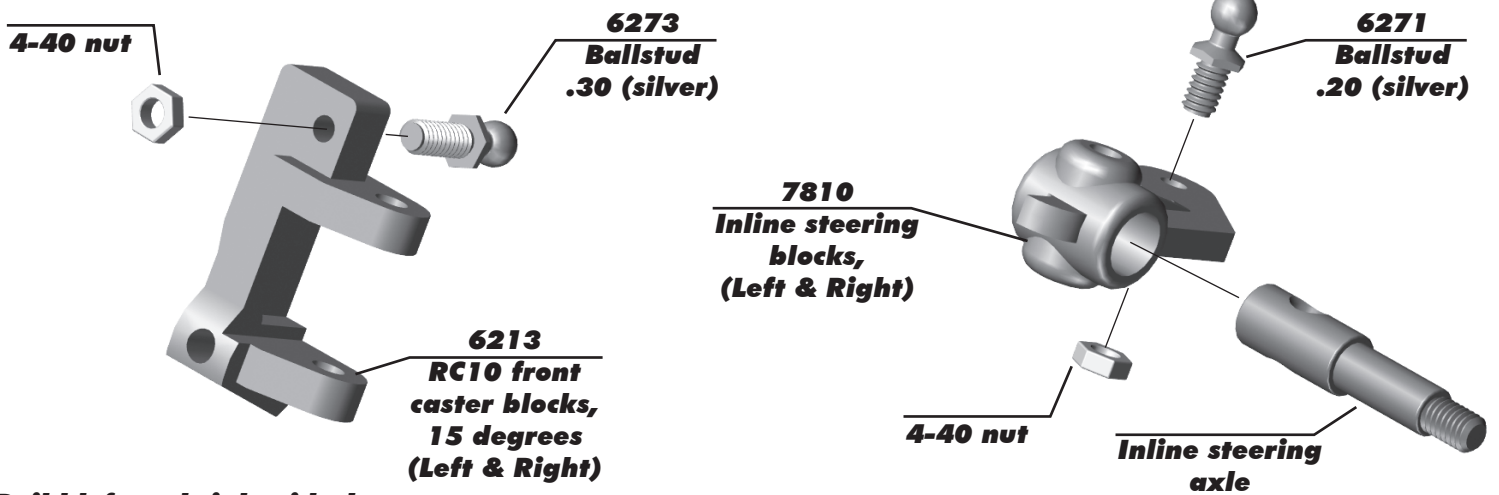

Build left and right sides!

:: Nose Plate / Steering Build - Bag A - Step 2

LEFT

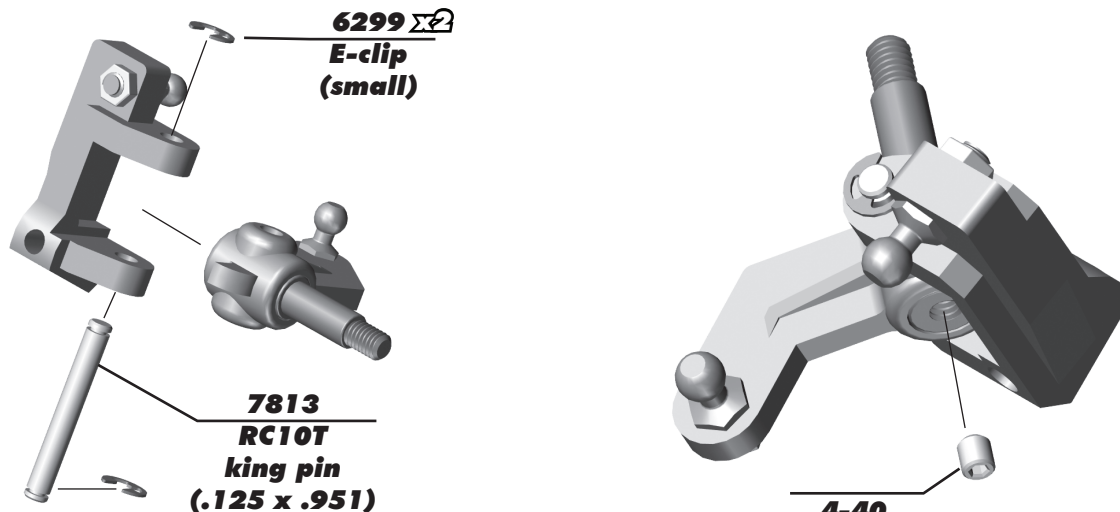

Build left and right sides!

Build left and right sides!

:: Nose Plate / Steering Build - Bag A - Step 3

LEFT

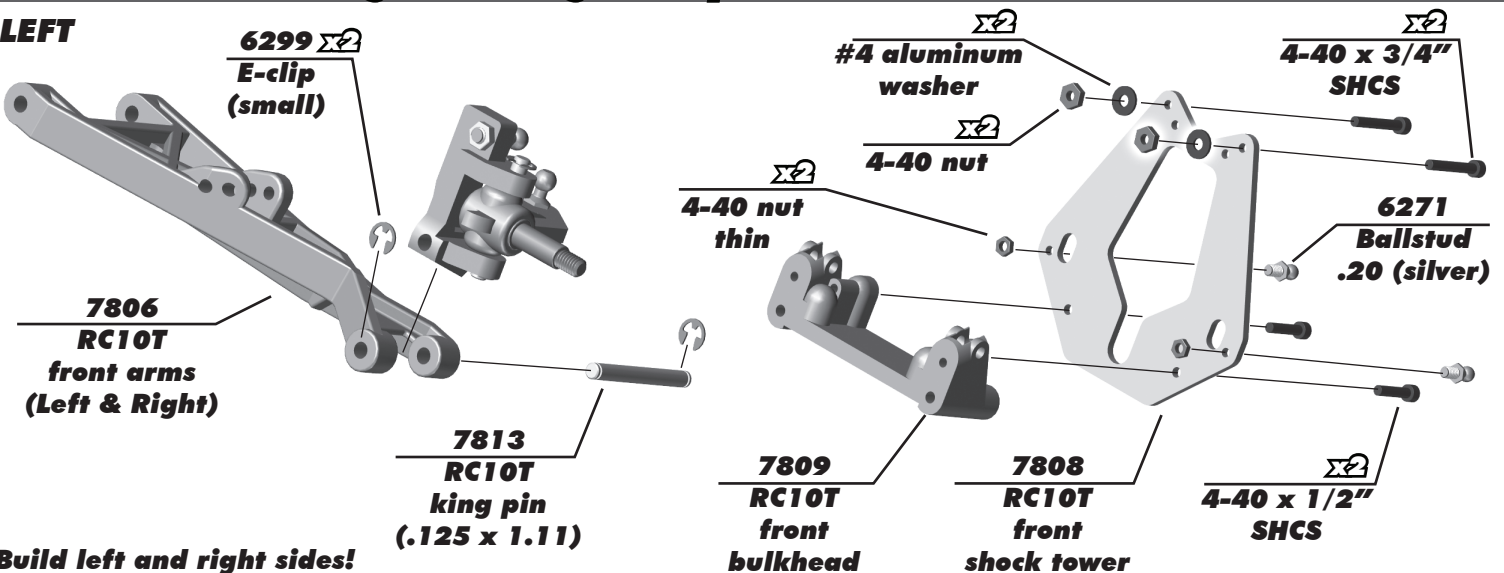

Build left and right sides!

:: Nose Plate / Steering Build - Bag A - Step 4

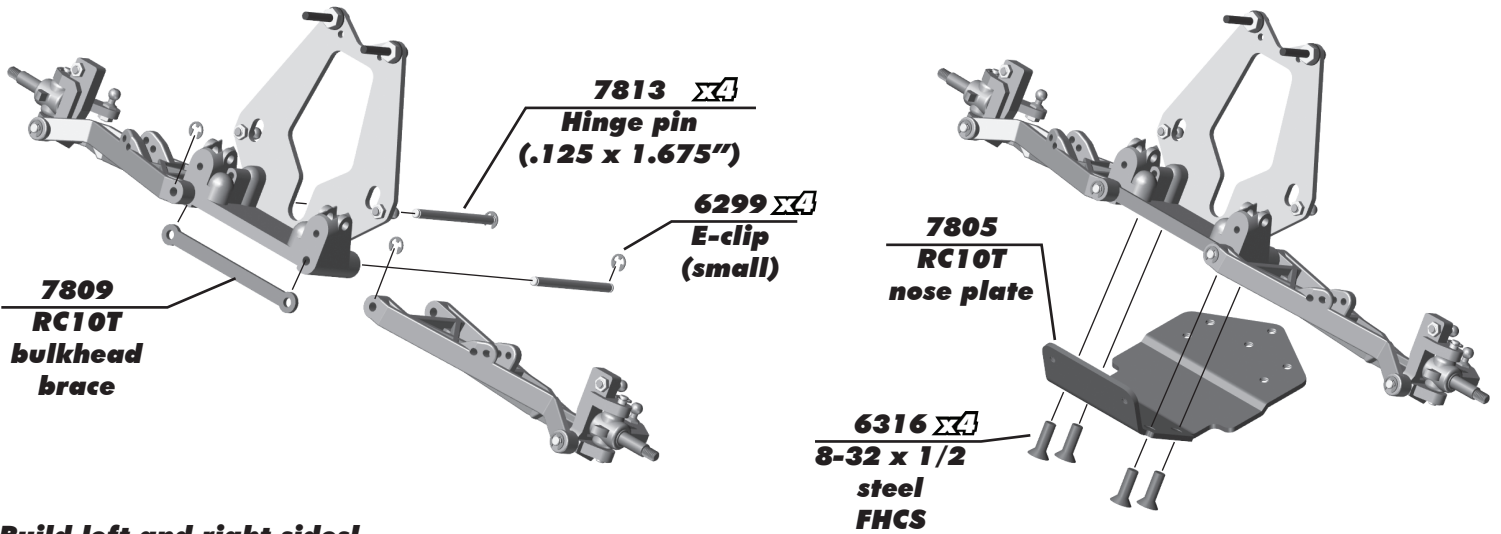

Build left and right sides!

:: Nose Plate / Steering Build - Bag A - Step 5

:: Servo Saver Build - Bag B / I - Step 1

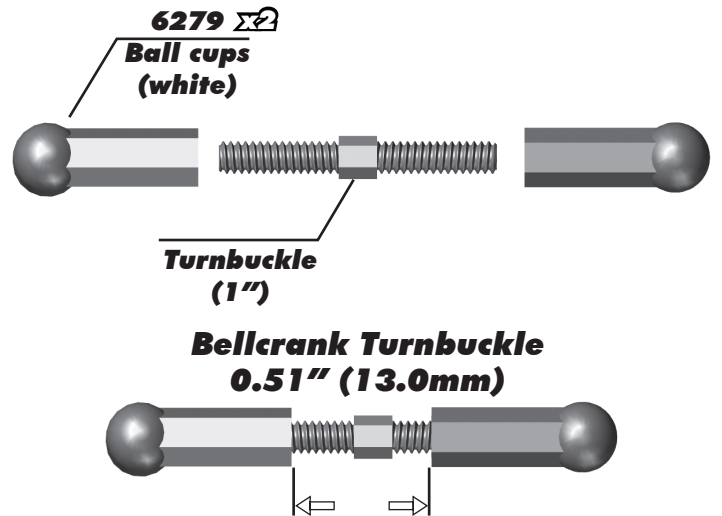
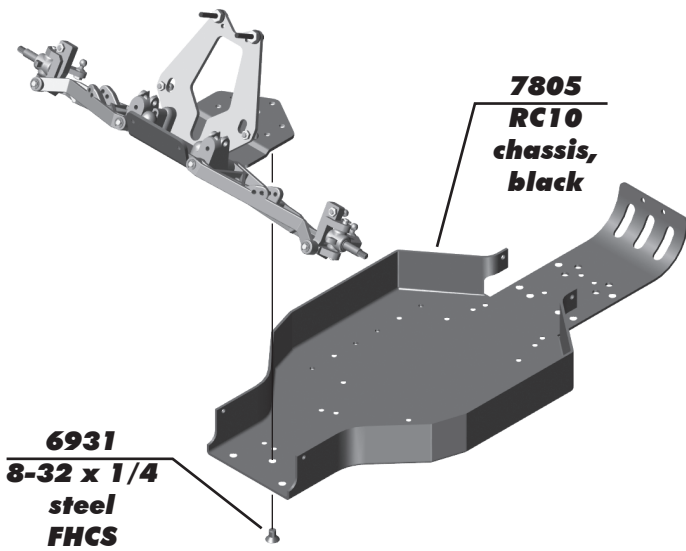

:: Servo Saver Build - Bag B - Step 2

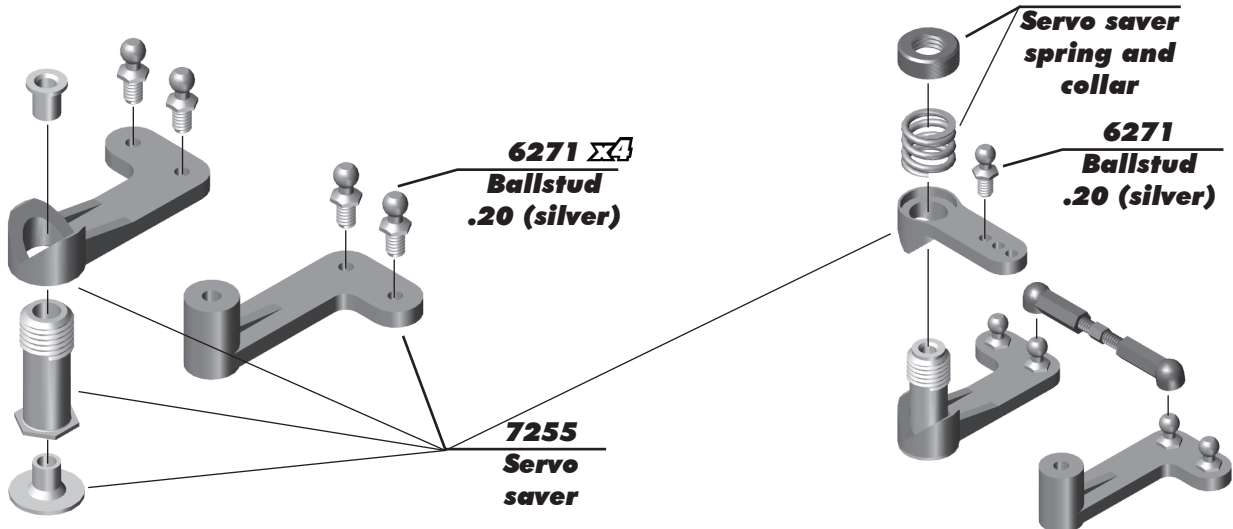

:: Servo Saver Build - Bag B - Step 3

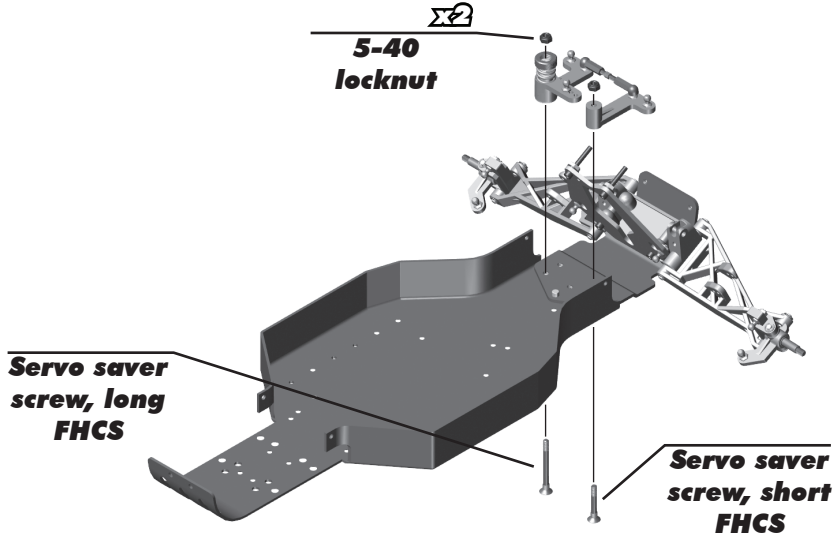

:: Servo Saver Build - Bag A / B / I - Step 4

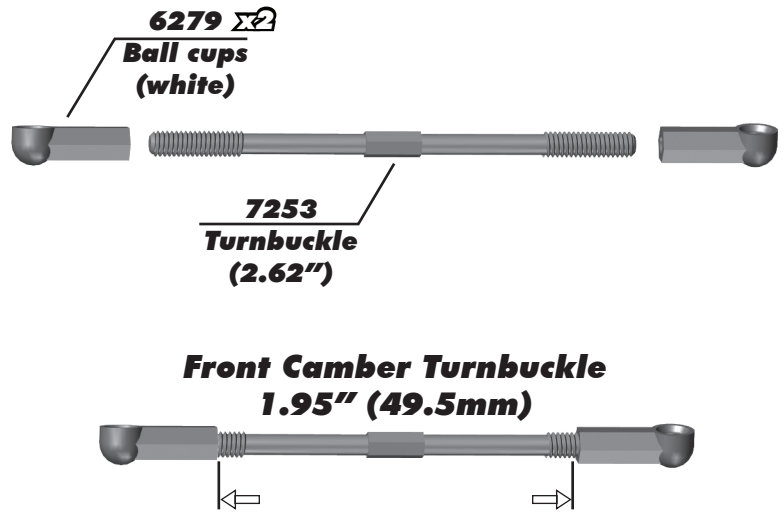
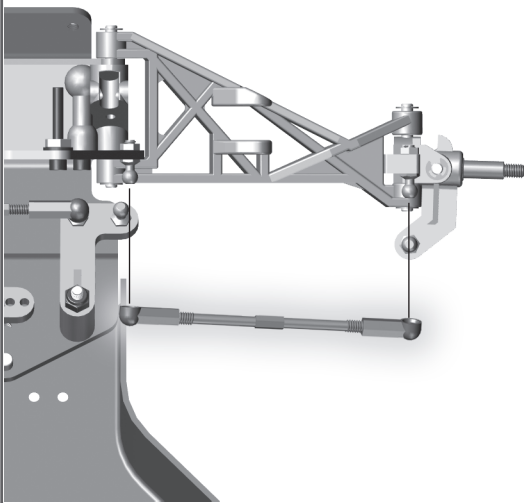

Build left and right sides!

:: Servo Saver Build - Bag B / I - Step 5

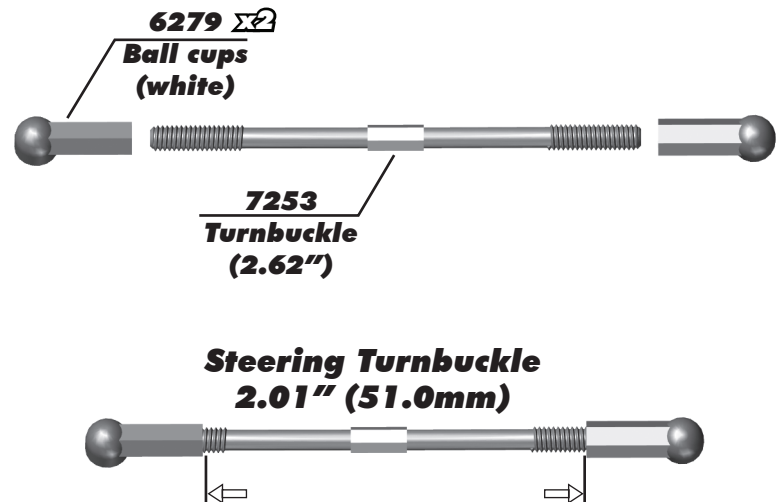
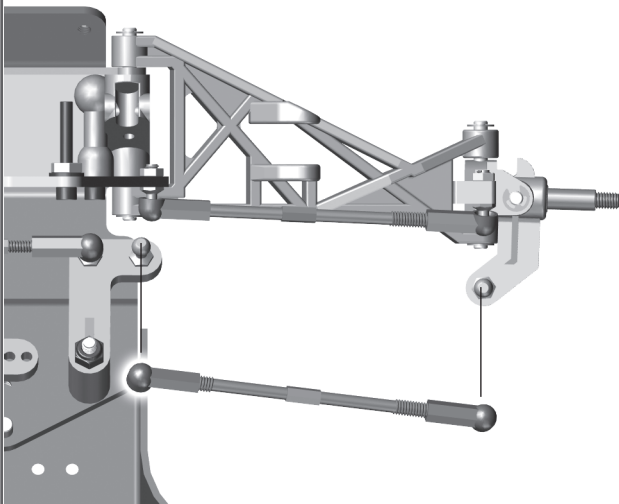

Build left and right sides!

:: Servo Saver Build - Bag A / B / I - Step 6

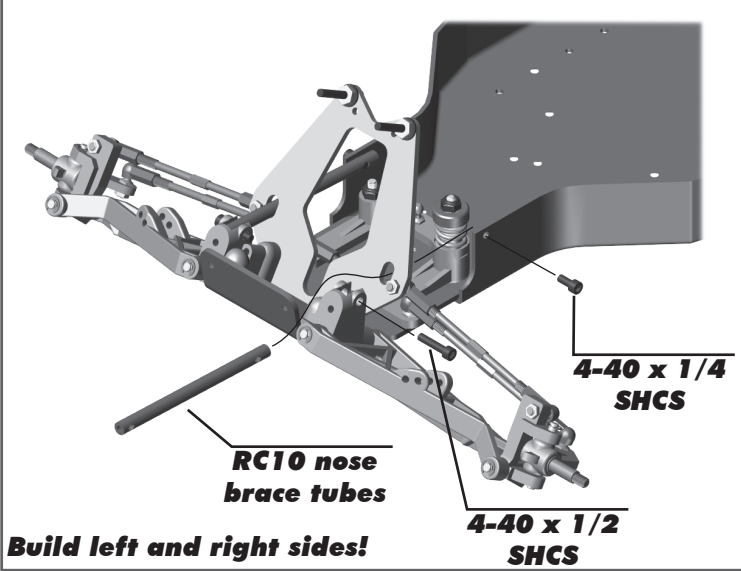

:: Bumper / Mounts Build - Bag C / D - Step 1

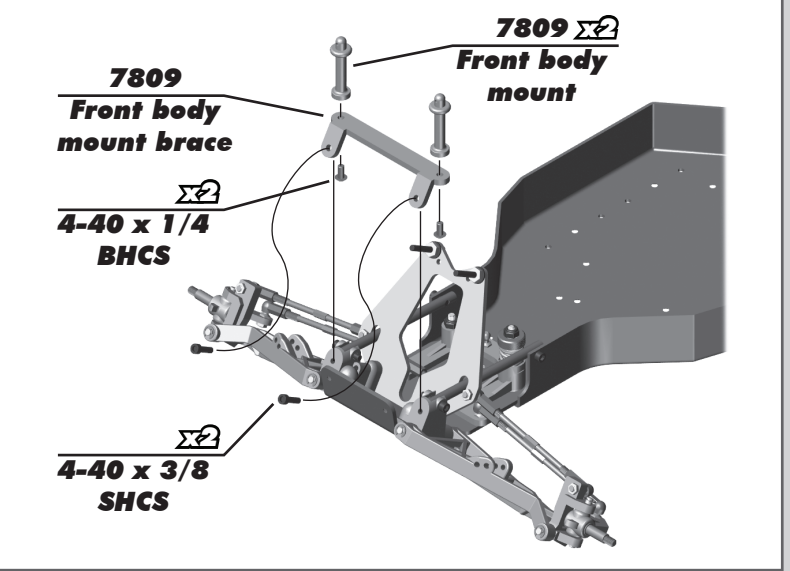

:: Bumper / Mounts Build - Bag C / D - Step 2

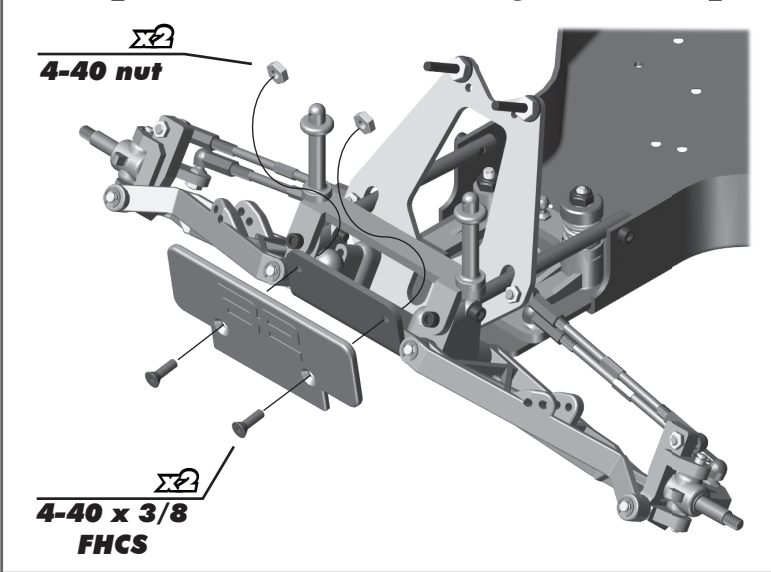

:: Servo Build - Bag E / I - Step 1

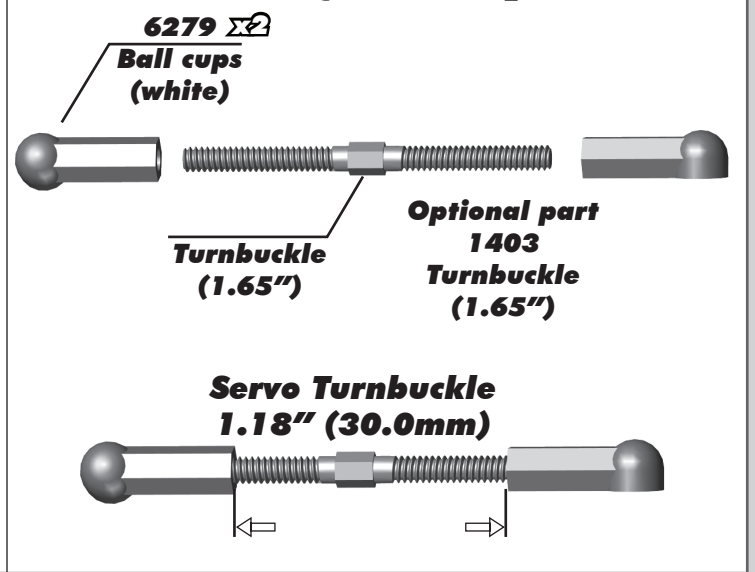

:: Servo Build - Bag E - Step 2

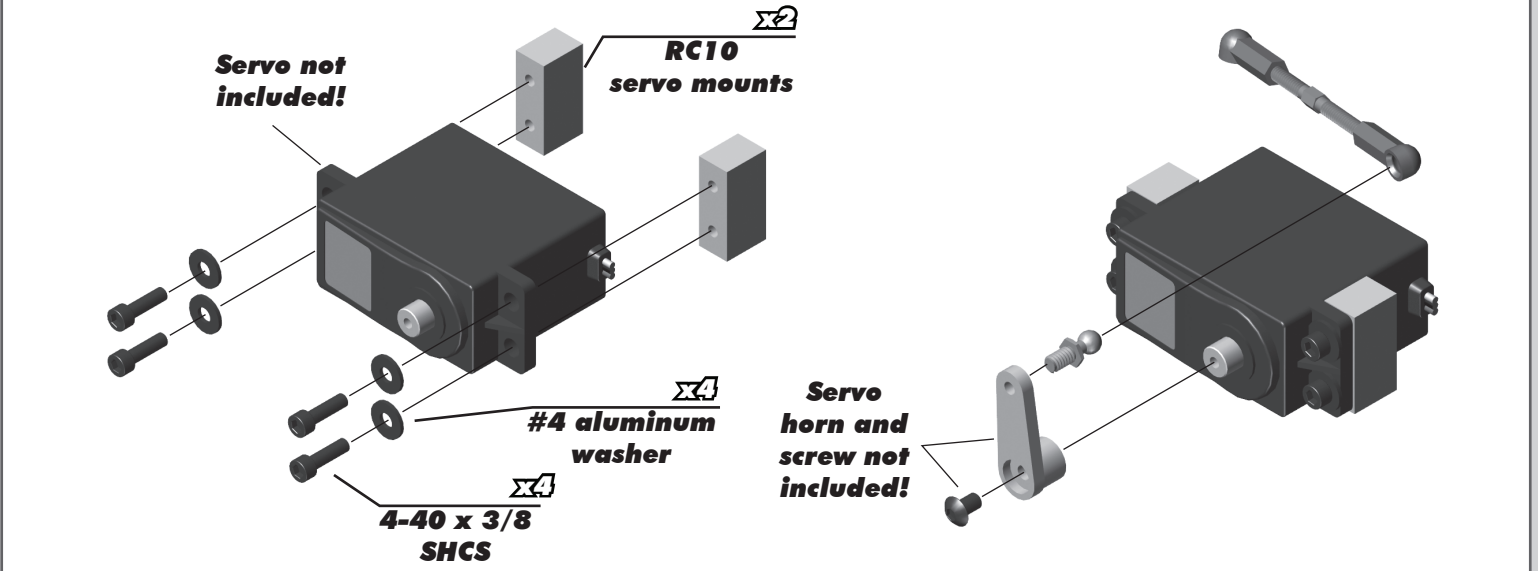

:: Servo Build - Bag E - Step 3

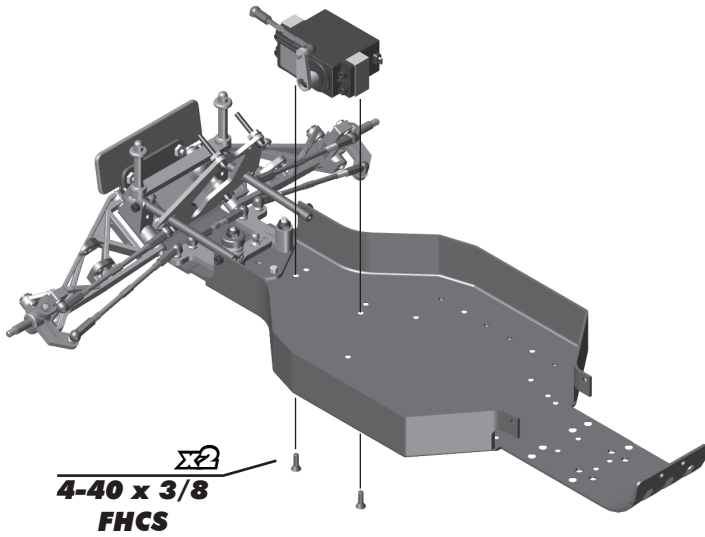

:: Battery Cup Build - Bag F - Step 1

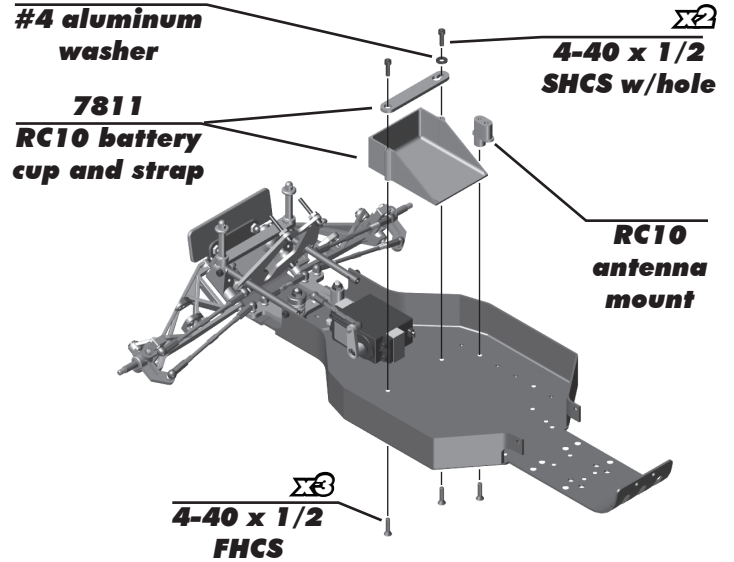

:: Rear End Build - Bag G - Step 1

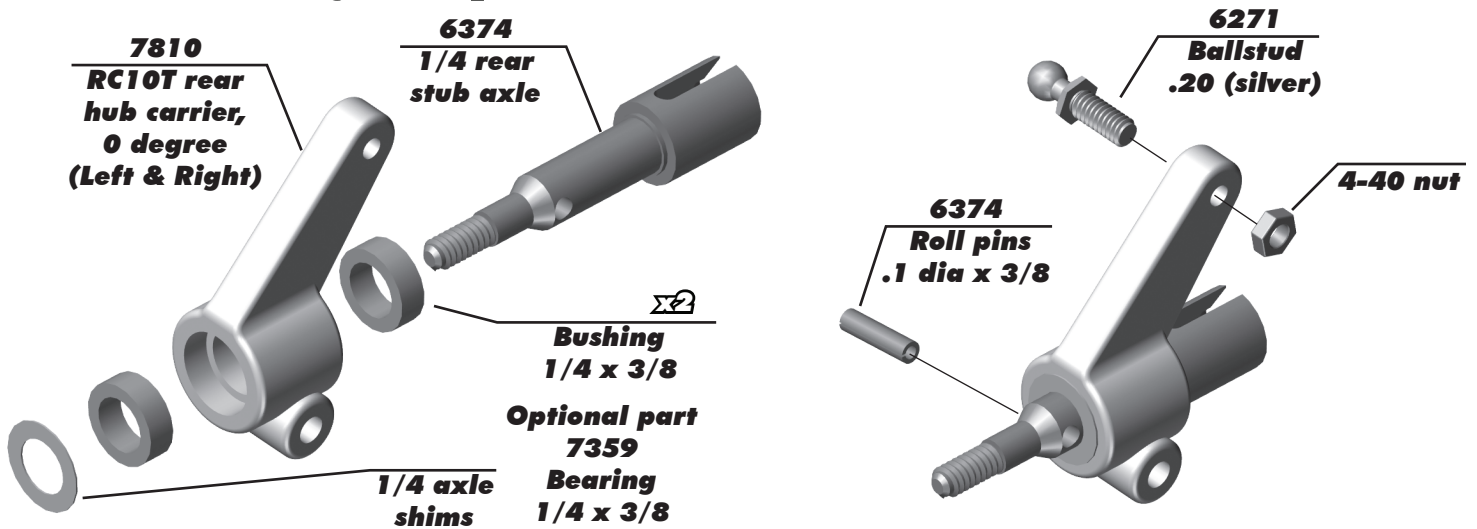

Build left and right sides!

:: Rear End Build - Bag G - Step 2

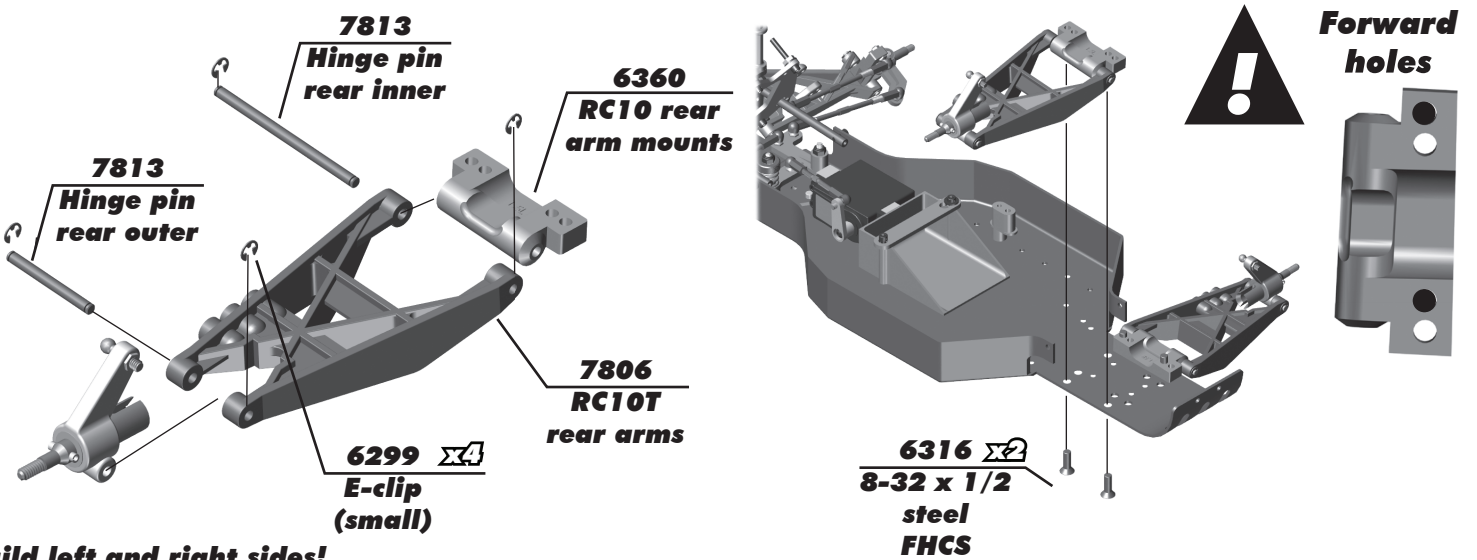

Build left and right sides!

:: Rear End Build - Bag G - Step 3

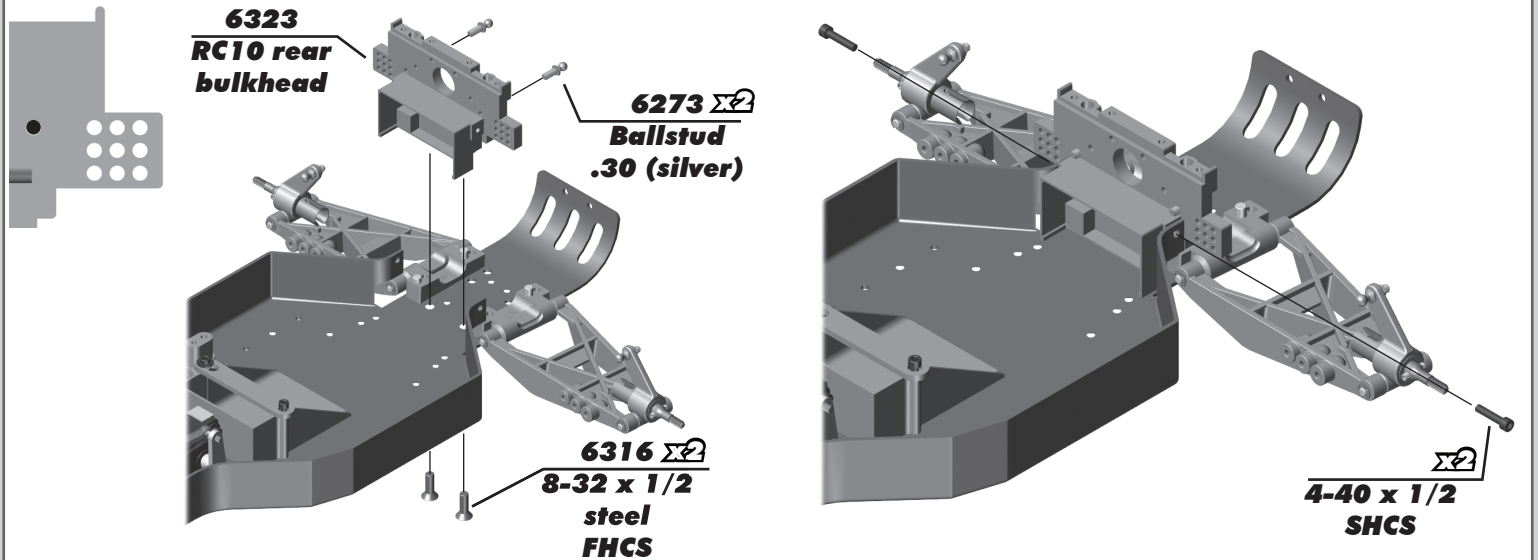

:: Rear End Build - Bag G / I - Step 4

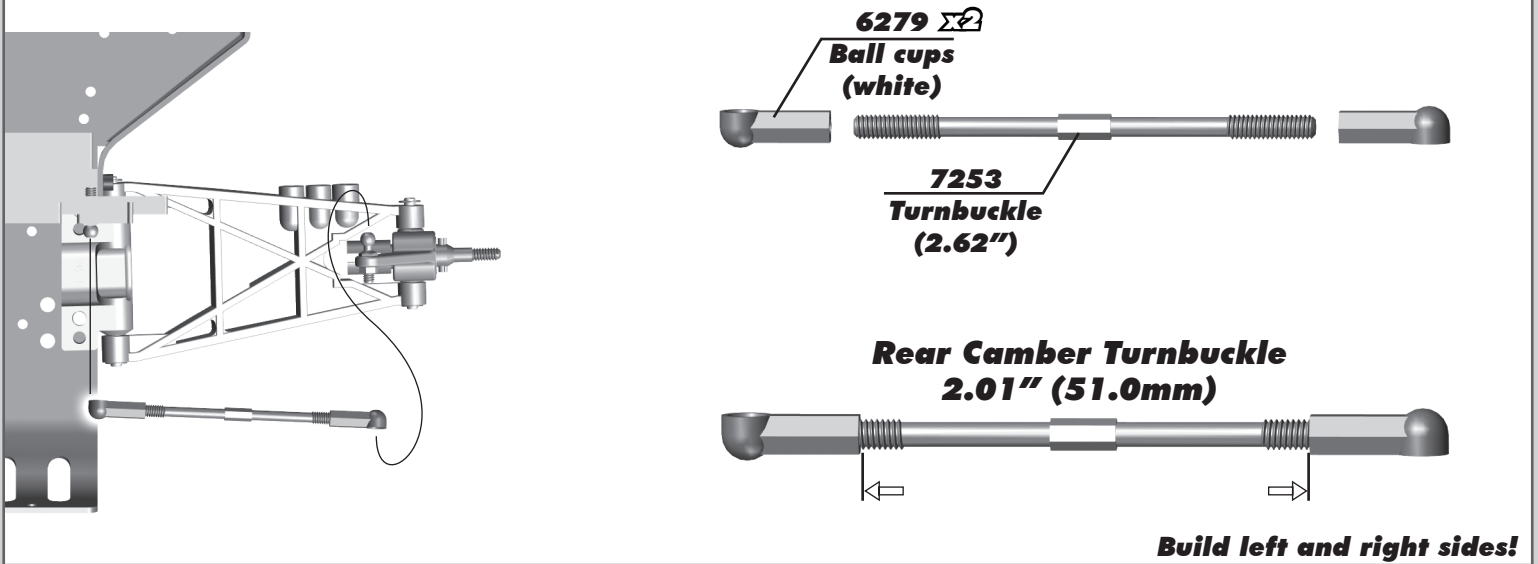

:: Rear End Build - Bag G - Step 5

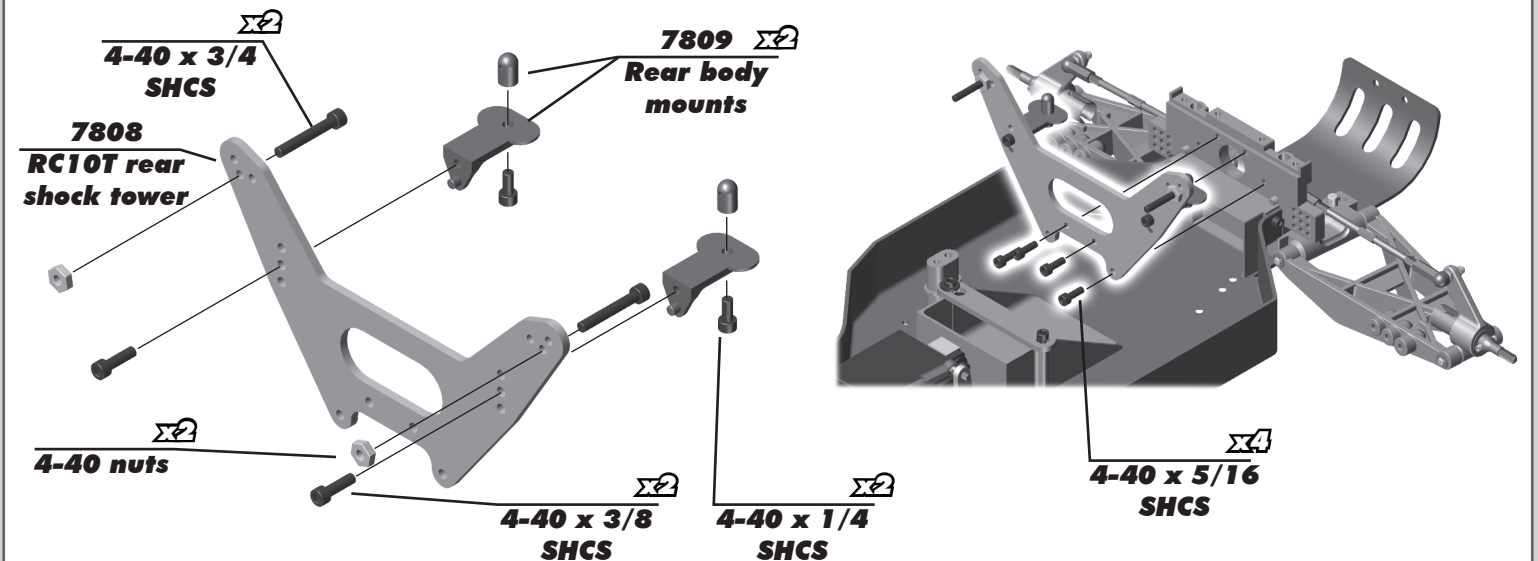

:: Shocks Build - Bag H - Step 1

Remove spurs

Piston

Piston number here
Use #2 = front shocks
Use #1 = rear shocks

TIP: Use marker to mark the piston numbers for easy identification!

6299 E-clip (small)

6421 Shock shaft, front (1.02)

6420 Shock shaft, rear (1.32)

Shock pistons (1, 2, 3)

6299 E-clip (small)

Build two front and two rear!

:: Shocks Build - Bag H - Step 2

5407 Σ 2 Red o-ring

6420 / 6421 Σ 2 Off-road shock internals

Remove spurs

Shock assembly tool

6421 Shock body, front (1.02) Gold

6420 Shock body, rear (1.32) Gold

Front Shock

Rear Shock

Shock fluid 30wt #5422

SNAP!

SNAP!

Place on table and push down hard until clamp snaps into place

:: Shocks Build - Bag H - Step 3

Front Shock

Rear Shock

6420 / 6421 Shock cap o-ring

6420 / 6421 Shock pivot ball

6420 / 6421 Shock rod end

6420 / 6421 Σ 2 Shock downstops

Build two front and two rear!

:: Shocks Build - Bag H - Step 4

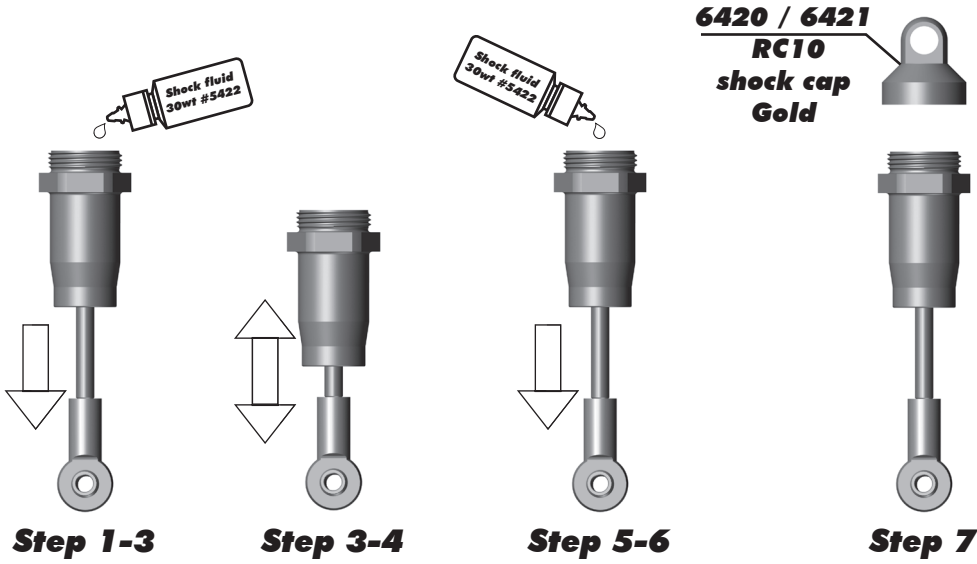

*** Shock Bleeding Steps:**

1. Pull shock shaft down.
2. Fill shock body 3/4 full with silicone fluid.
3. Slowly move the shock shaft up and down to remove air from under piston.
4. Wait for bubbles to come to surface.
5. Fill shock body to top with silicone fluid.
6. Place several drops of oil in the cap and on cap threads.
7. Install cap and tighten completely.
8. Slowly compress shaft all the way to the top. If there is pressure at the top of the stroke, there is too much oil. You must bleed it out.
9. Slowly pull shaft down.
10. Unscrew the cap 3/4 turn and tilt the shock at a slight angle.
11. Slowly compress the shaft to push out excess oil and air. You should see bubbles coming out from under the cap.
12. With the shaft compressed, tighten the cap and re-check for pressure at the top of the stroke. If there is still pressure, repeat steps 9 thru 11.

:: Shocks Build - Bag H - Step 5

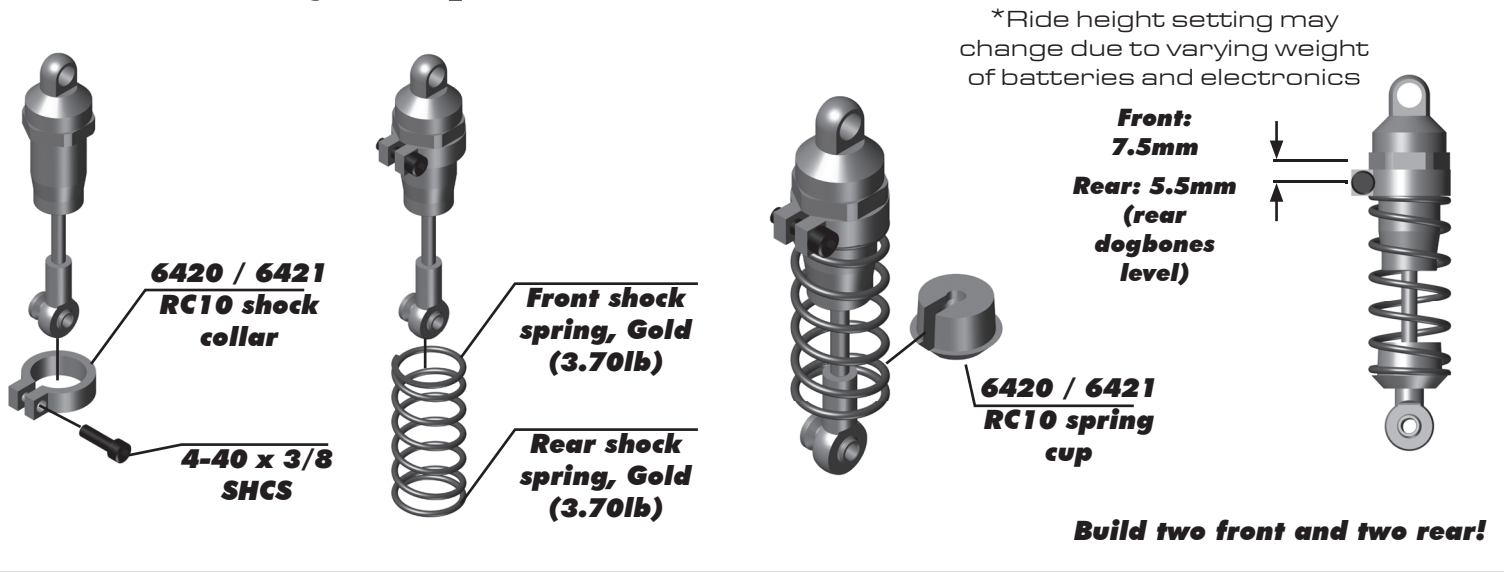

:: Shocks Build - Bag H - Step 6

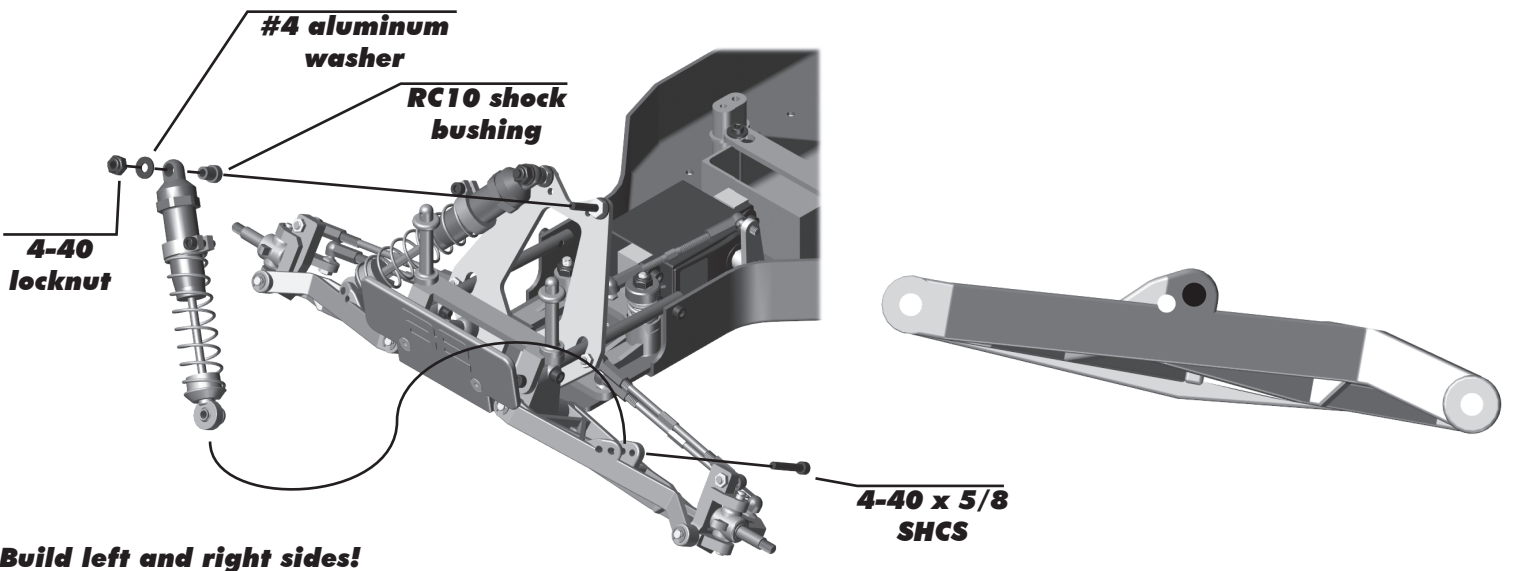

:: Shocks Build - Bag H - Step 7

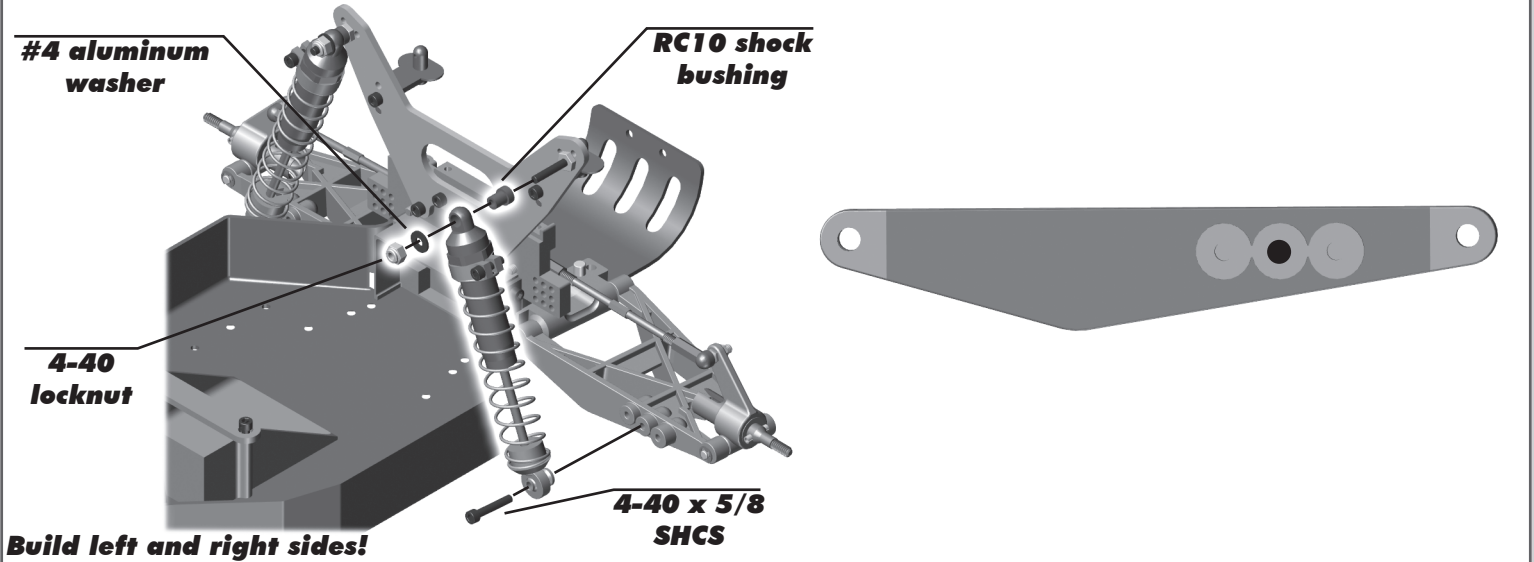

:: Transmission Build - Bag J / K - Step 1

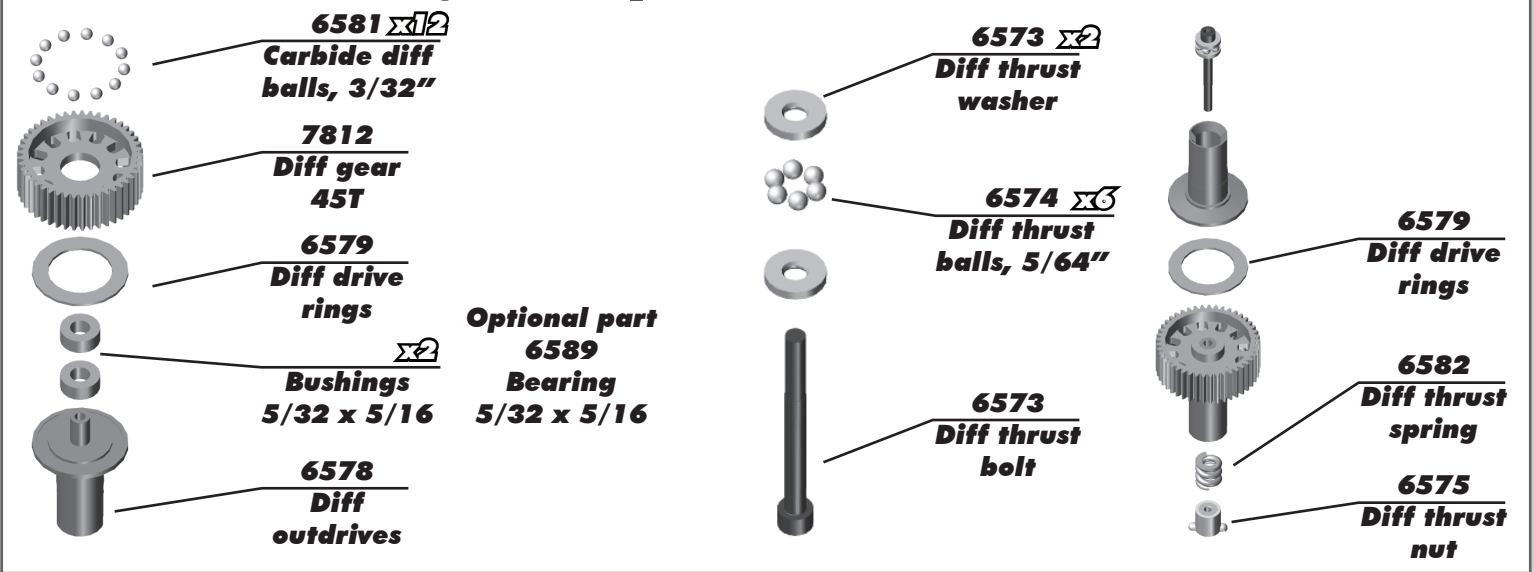

:: Transmission Build - Bag J / K - Step 2

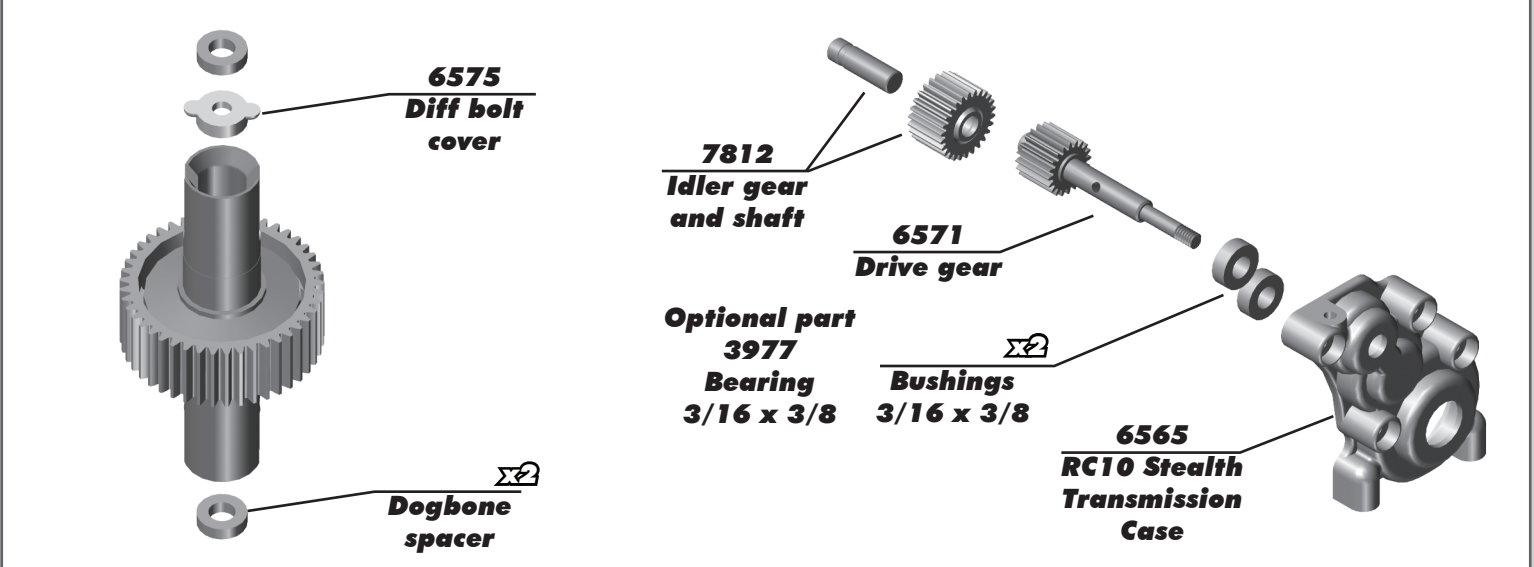

:: Transmission Build - Bag J / K - Step 3

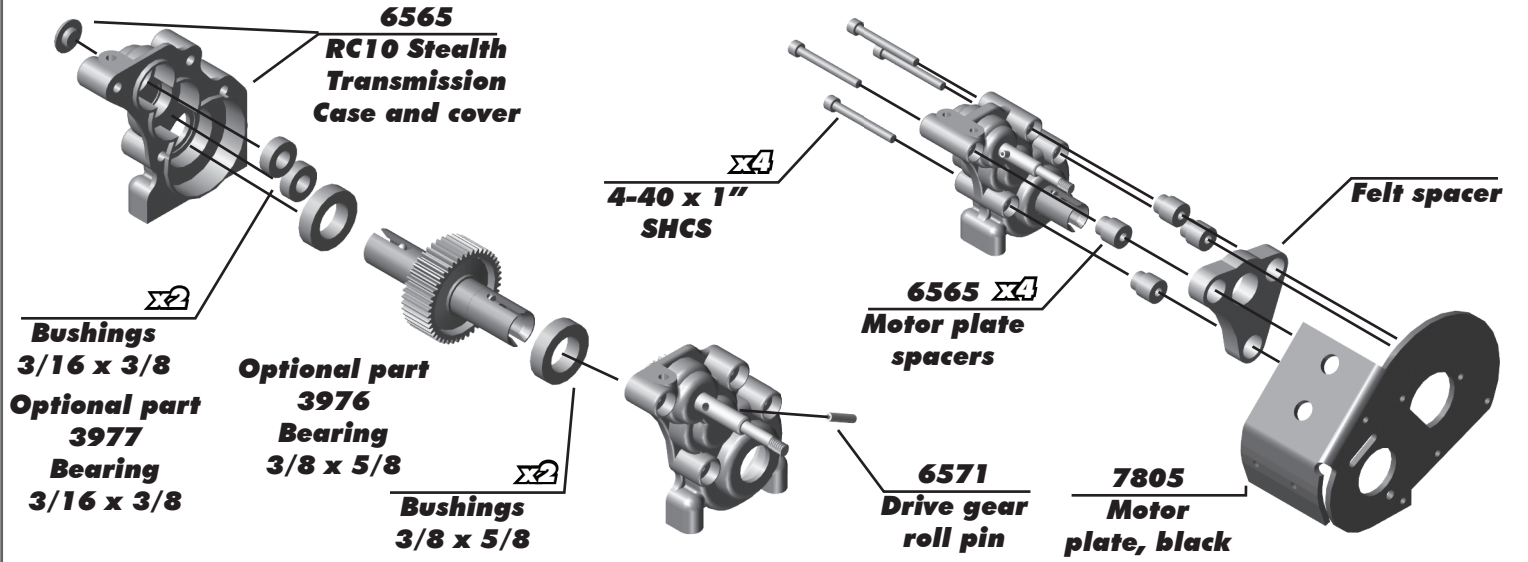

:: Transmission Build - Bag J / K - Step 4

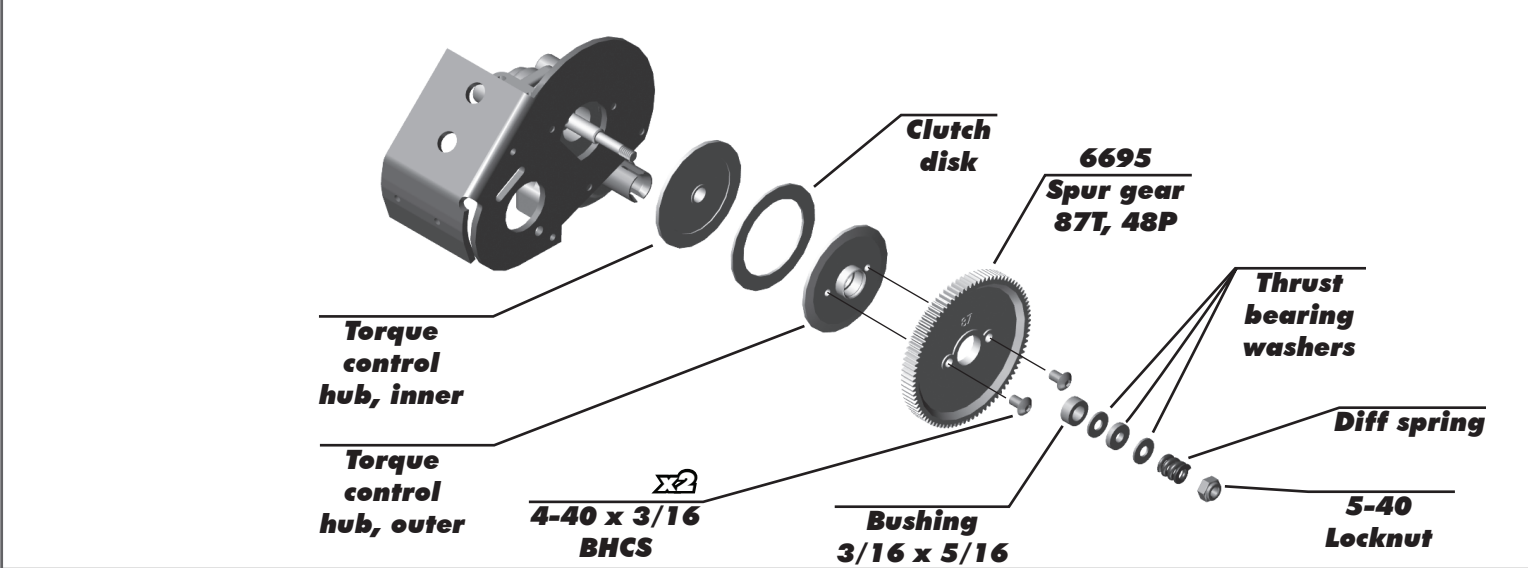

:: Transmission Build - Bag J / K - Step 5

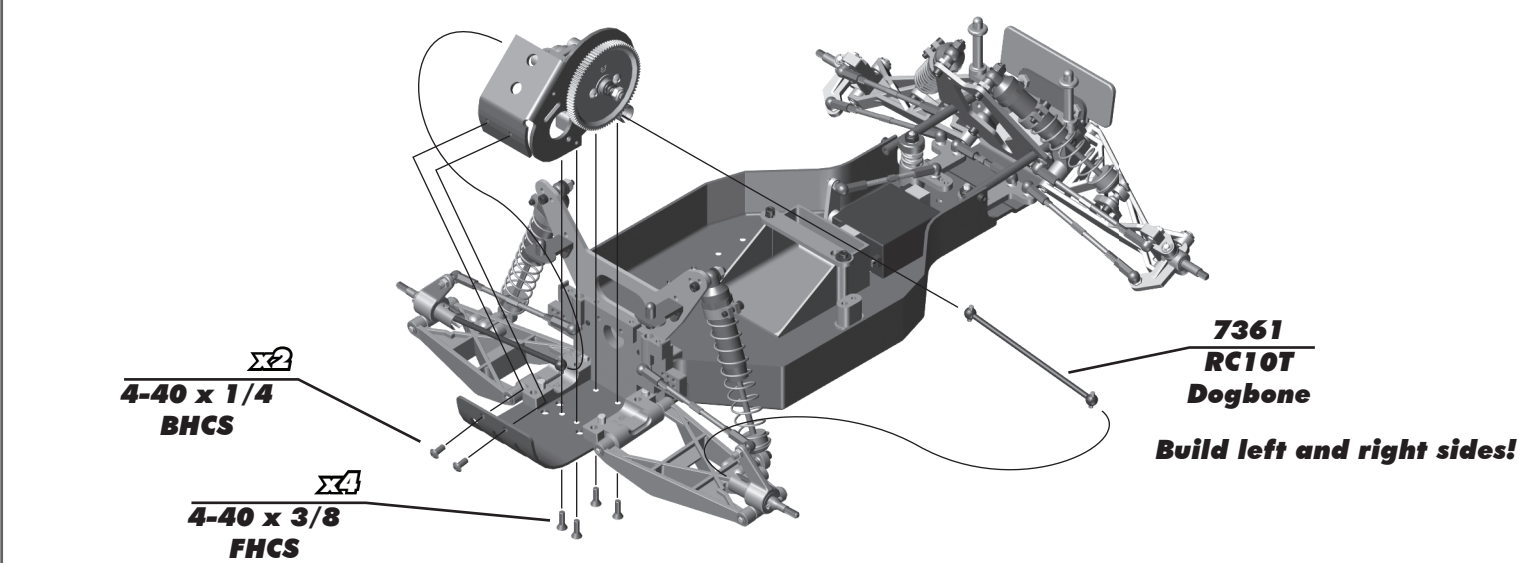

:: Transmission Build - Bag J / K - Step 6

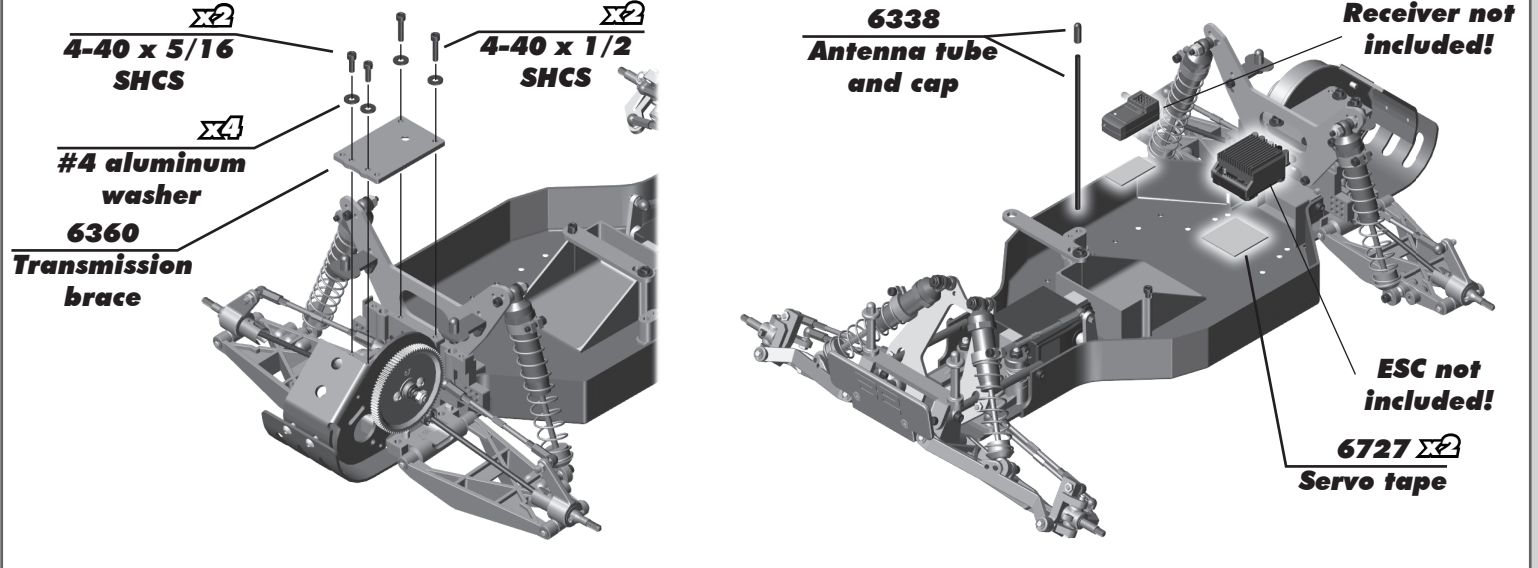

:: Transmission Build - Bag J / K - Step 7

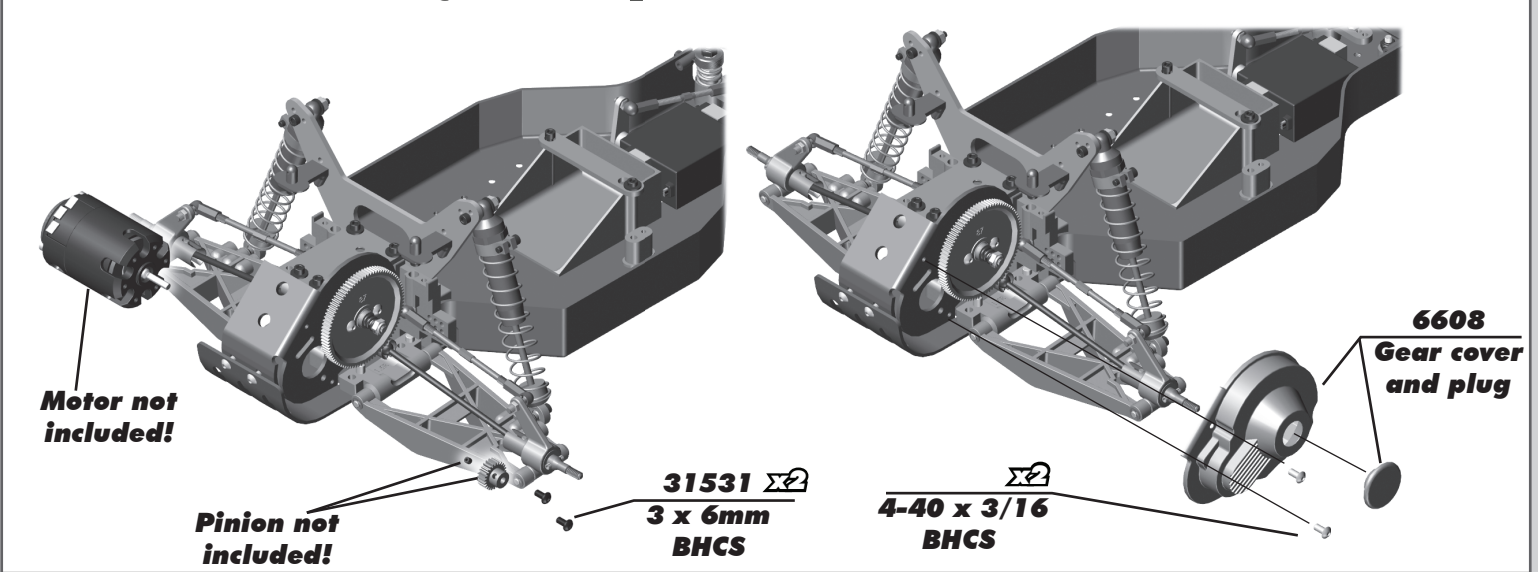

:: Transmission Build - Bag J / K - Step 8

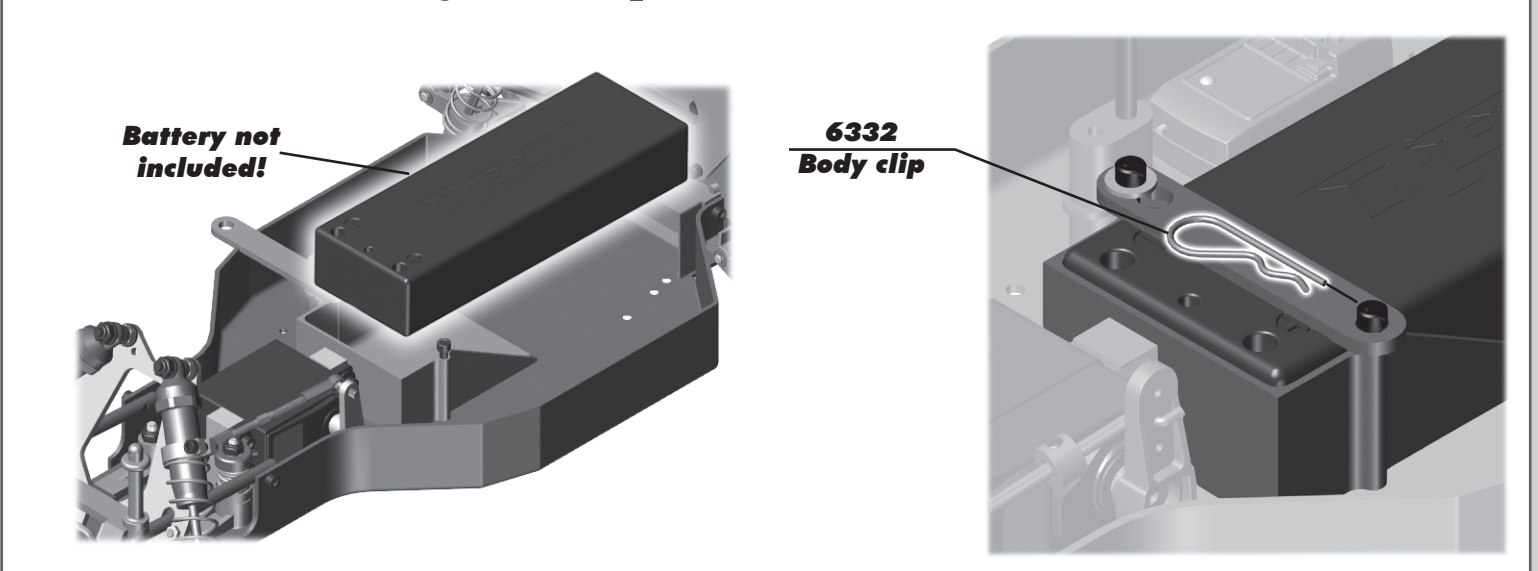

:: Body Build - Step 1

Painting Tips:

Your RC10T Kit comes with a clear polycarbonate body and wing. You will need to prep the body and wing before you can paint them. Wash the inside thoroughly with warm water and liquid detergent. Dry the body and wing using a clean, soft, lint-free cloth. Use high quality masking tape to make masks for the windows and install them on the inside of the body (RC cars get painted from the inside). Using high quality masking tape, apply tape to the inside of the body to create a design. Spray (either rattle can or airbrush RC specific paint) the paint to the inside of the body (preferably dark colors first, lighter colors last).

NOTE: use ONLY paint that is recommended for use with (polycarbonate) plastics. If you do not, you can destroy the plastic body and wing!). It is recommended to wear a mask while painting.

After the paint has dried, cut the body and wing along the trim lines. Make sure to drill or use a body reamer to make the holes for the body mounts, wing mounts, and antenna!

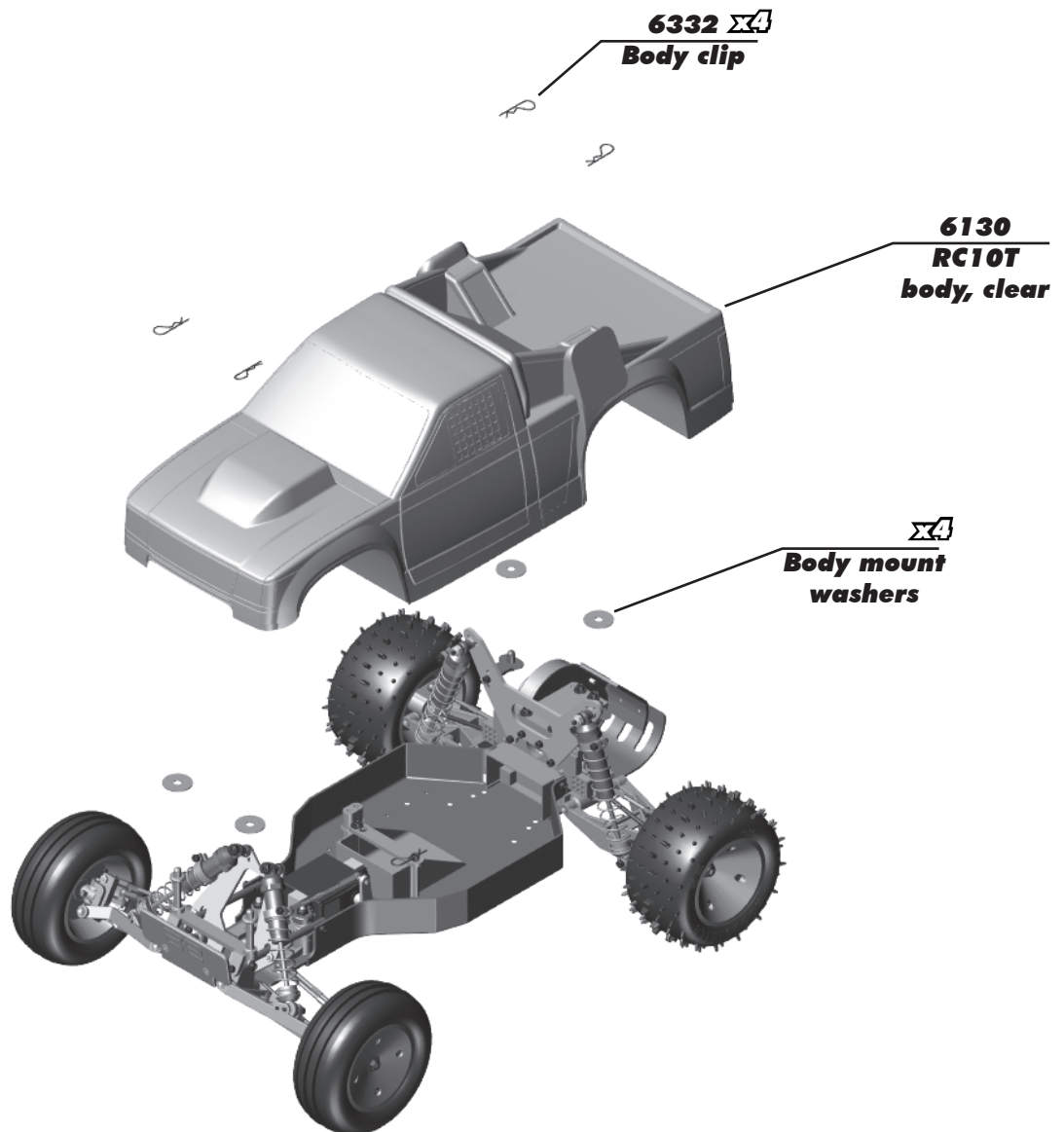

FIND IT ON ASSOCIATEDELECTRICS.COM

CARS & TRUCKS



Vehicle Spare Parts

GO TO:

[AssociatedElectrics.com](#) →
[Team Associated tab](#) →
[Cars & Trucks](#) →
[Scroll to your vehicle](#) →
[Parts & Accessories link](#)

SETUP SHEETS & MANUALS



Setups and Manuals

GO TO:

[AssociatedElectrics.com](#) →
[Team Associated tab](#) →
[Manuals & Setups](#) →
[Scroll to your vehicle](#)

A-TEAM APPS



Tuning Guides & Tips

GO TO:

[AssociatedElectrics.com](#) →
[Support](#) →
[A-Team Apps](#)



Associated Electrics, Inc.

21062 Bake Parkway Lake Forest, CA 92630 USA

call: (949) 544-7500 - fax: (949) 544-7501

**Check out the following web sites for all of our kits, current products,
new releases, setup help, tips, and racing info!**

www.AssociatedElectrics.com

FOLLOW US ON SOCIAL MEDIA



TeamAssociated
ReedyPower
ElementRC
Factory Team



@TeamAssociatedRC
@ReedyPower
@Element_RC
@FactoryTeam_RC

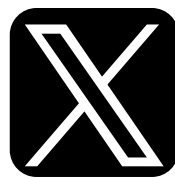

@Team_Associated
@ReedyPower



@Associated_Electrics