

# DR10M

MID-MOTOR DRAG CAR

1:10 Scale 2WD Electric  
Drag Race Car Kit

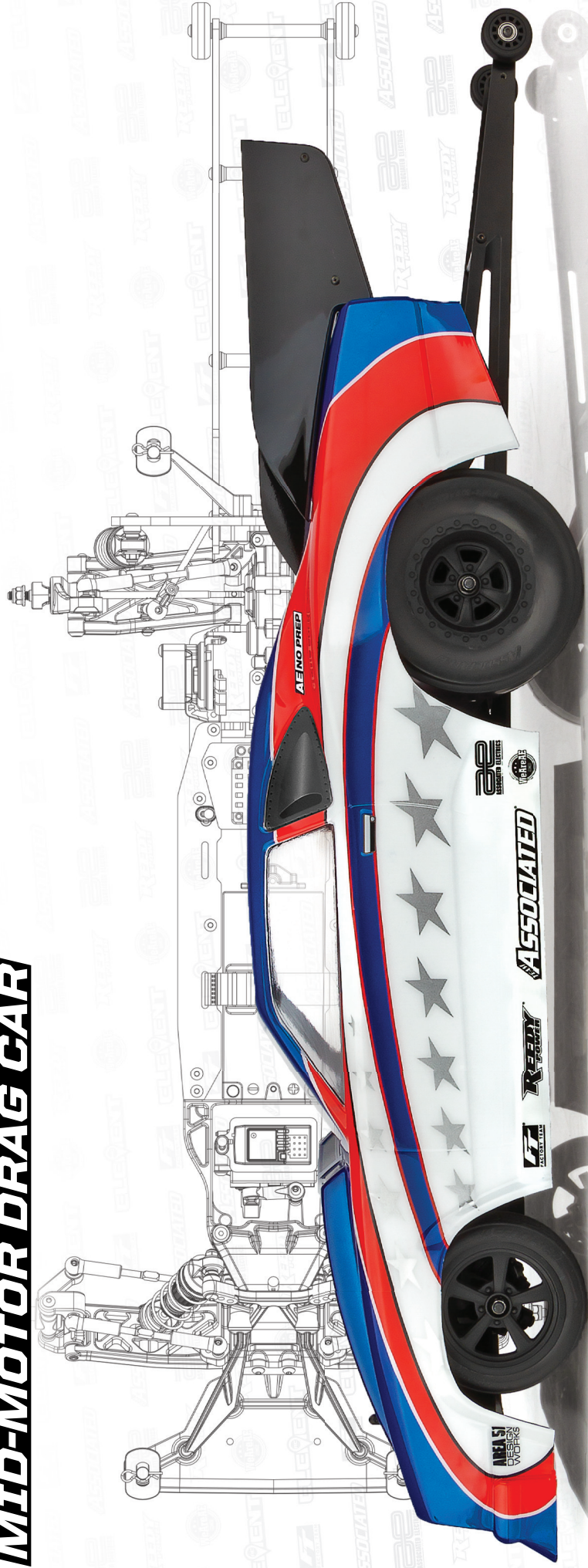

SCALE 1:10 VEHICLE

KIT

2 WHEEL DRIVE

ELEC. POWERED

ON ROAD

NOT INCLUDED

NOT INCLUDED

#70029 DR10M TEAM KIT

1:10 Scale 2WD Electric Off Road Drag Race Car Manual

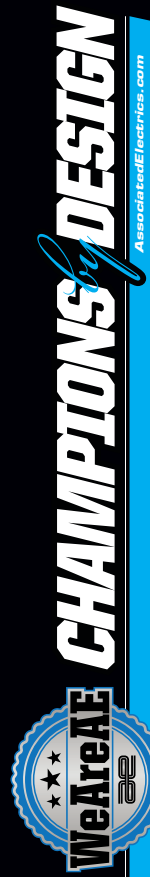

AssociatedElectrics.com

## :: Introduction

Thank you for purchasing this Team Associated product. This assembly manual contains instructions and tips for building and maintaining your new vehicle. Please take a moment to read through this manual to help familiarize yourself with these steps. We are continually changing and improving our designs; therefore, actual parts may appear slightly different than in the illustrations. New parts will be noted on supplementary sheets.

## :: KIT Features

- Mid-motor design creates improved traction and control in the vehicle's weight distribution
- Metric hardware throughout
- 28 precision ball bearings
- Durable front and rear wide body mounts
- Rear CVA drive shafts for more reliability
- V2 12mm Big Bore threaded aluminum shocks
- Rigid 4mm thick carbon fiber rear shock tower
- Heavy-duty sealed silicone-filled gear differential
- Stiff rear anti-roll bar
- Full adjustable double-ladder wheelie bar
- Low center-of-gravity chassis with multiple battery and electronics mounting configurations
- Rigid twin deck chassis design
- Ball bearing wheelie bar wheels with rubber tires for increased straight-line stability
- Machined aluminum rear bulkheads
- Machined aluminum rear suspension mounts
- Height adjustable rear gearbox provides the ability to adjust drive shaft angle
- All metal gear transmission with hardened steel top shaft
- Rugged steel turnbuckles for adjustable camber and front toe-in
- Adjustable suspension geometry
- Octalock spur gear and 11mm Octalock pads for maximum consistency and higher torque capacity
- 4-gear rear transmission configuration aids in controlling weight movement providing more traction under acceleration
- Vertical ball ends for roll center adjustments, front and rear
- Many Factory Team options already available

## :: Additional

Your new Kit comes unassembled and requires the following items for completion:

- R/C two channel surface frequency radio system
- Electronic Speed Control, ESC
- 540 size electric motor
- Peak detection battery charger, or LiPo compatible charger
- Polycarbonate specific spray paint
- Cyanoacrylate glue (CA)(#1597)
- AA-size batteries for transmitter (#302 alkaline)
- Steering servo
- Pinion gear (48P), size determined by type/wind of motor
- 2 cell LiPo battery pack
- Thread locking compound (#1596)
- Tires and Inserts, Fronts and Rears

## :: Other Helpful Items

- Silicone Shock Fluid (Refer to catalog for complete listings)
- Body Scissors (AE Part #1737)
- FT Hex/Nut Wrenches (AE Part #1519, 1650)
- Green Slime shock lube (AE Part #1105)
- Soldering Iron
- FT Body Reamer
- FT Ballcup Wrench (#1579)
- FT Dual Turnbuckle Wrench (#1114)
- Hobby Knife / Wire Cutters
- Shock Pliers
- FT Universal Tire Balancer (#1498)
- Calipers or a Precision Ruler
- Needle Nose Pliers

















**Associated Electrics, Inc.**  
21062 Bake Parkway.  
Lake Forest, CA 92630



**Customer Service**  
Tel: 949.544.7500  
Fax: 949.544.7501

**:: Hardware - 1:1 Scale View**







**Button Head (bhcs)**

-  **2x3mm (31509)**
-  **2x4mm (31510)**  
**Aluminum (8545)**
-  **2.5x6mm (31520)**
-  **2.5x8mm (31521)**
-  **2.5x10mm (31522)**
-  **3x5mm (31530)**
-  **3x8mm (31532)**
-  **3x10mm (25211)**
-  **3x12mm (89202)**
-  **3x14mm (25187)**
-  **3x16mm (89203)**
-  **3x20mm (25188)**
-  **3x22mm (25189)**
-  **3x24mm (89204)**
-  **3x26mm (89205)**
-  **3x30mm (91478)**

**Cap Head (shcs)**

-  **2.5x12mm (8691)**
-  **2.5x14mm (71032)**
-  **3x24mm (89225)**

**Flat Head (fhcs)**

-  **3x8mm (25201)**
-  **3x10mm (25202)**
-  **3x12mm (25203)**
-  **3x14mm (89208)**
-  **3x16mm (25204)**
-  **3x18mm (89209)**
-  **3x20mm (89210)**

**Set Screws**

-  **3x3mm (25225)**
-  **3x5mm (89219)**





**Shims and Washers**

-  **3 x 8mm Washer (89218)**
-  **FT Ballstud Washer, Aluminum (0.5mm) (31381)**
-  **FT Ballstud Washer, Aluminum (1mm) (31382)**
-  **FT Ballstud Washer, Aluminum (2mm) (31383)**

**Clips**

-  **E-clip 1/8 (6299)**









**Ball Bearings**

-  **3x7x3mm (91475)**
-  **5x10x3mm (31734)**
-  **5x10x4mm (91560)**
-  **6x13x5 (91562)**
-  **10x15x4 (91563)**

**Ballstuds**

-  **HD 6mm (91047)**  
**Titanium HD 6mm (91751)**
-  **HD 8mm (91048)**  
**Titanium HD 8mm (91752)**
-  **HD 10mm (91049)**  
**Titanium HD 10mm (91753)**

**Nuts (lock/plain)**

-  **M2.5 Locknut, Shock Piston (89215)**
-  **M3 Nut (91477)**
-  **M3 Alum. Locknut, Blue (31550)**
-  **M3 Locknut, Black (25215)**
-  **M3 Locknut w/Flange (25612)**
-  **FT 3mm Locknuts, Blue (25392)**
-  **M4 Serrated w/Flange (91738)**
-  **FT M4 Locknuts w/Flange, Blue (31551)**

**Notes:**

**:: Table of Contents**

1.....	Cover	10 - 11.....	Bag 8: Gearbox Build
2.....	Introduction	12.....	Bag 9: Rear Hub Build
3.....	1:1 Hardware "Fold Out"	12 - 13.....	Bag 10: Turnbuckle Build
4.....	Table of Contents	13 - 15.....	Bag 11: Shocks Build
5.....	Bag 1: Front Top Plate and Steering Build	15.....	Bag 12: Anti-Roll Bar Build
6.....	Bag 2: Front Steering Block Build	16.....	Bag 13: Wheelie Bar Build
6.....	Bag 3: Front Suspension Build	16 - 18.....	Bag 14: Electronics Install
7.....	Bag 4: Rear Suspension Build	18.....	Wheels/Tires/Body Install
8.....	Bag 5: Rear Bulkhead Build	19 - 20.....	Tuning Tips
8 - 9.....	Bag 6: Side Brace Build	21.....	Setup Sheet
9 - 10.....	Bag 7: Gear Diff Build	22.....	Back Cover

**:: Notes**

***This symbol indicates a special note or instruction in the manual.***



***This symbol indicates a Racers Tip.***



***There is a 1:1 hardware foldout page in the front of the manual. To check the size of a part, line up your hardware with the correct drawing until you find the exact size. Each part in the foldout has a number assigned to it for ordering replacement parts.***

**Associated Electrics, Inc.  
21062 Bake Parkway.  
Lake Forest, CA 92630**



**Customer Service  
Tel: 949.544.7500  
Fax: 949.544.7501**



**:: Bag 1 - Step 1**

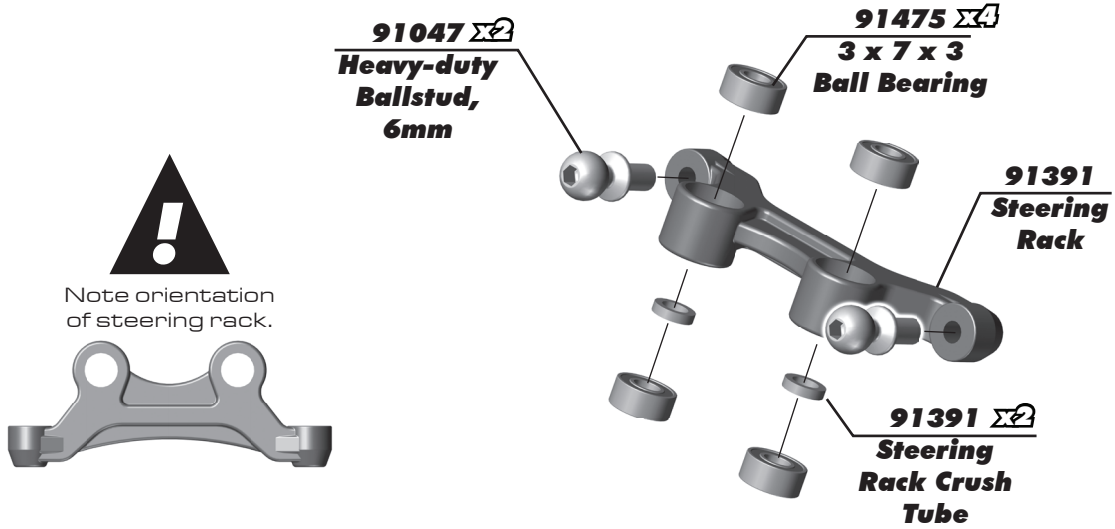

**:: Bag 1 - Step 2**

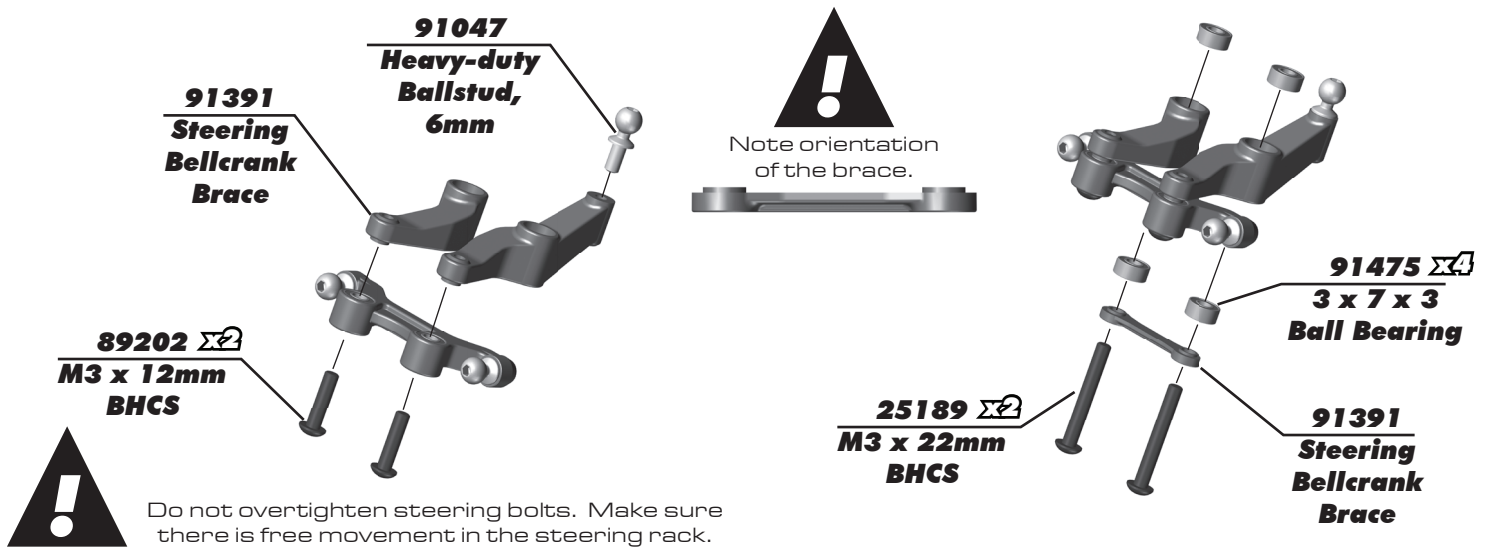

**:: Bag 1 - Step 3**

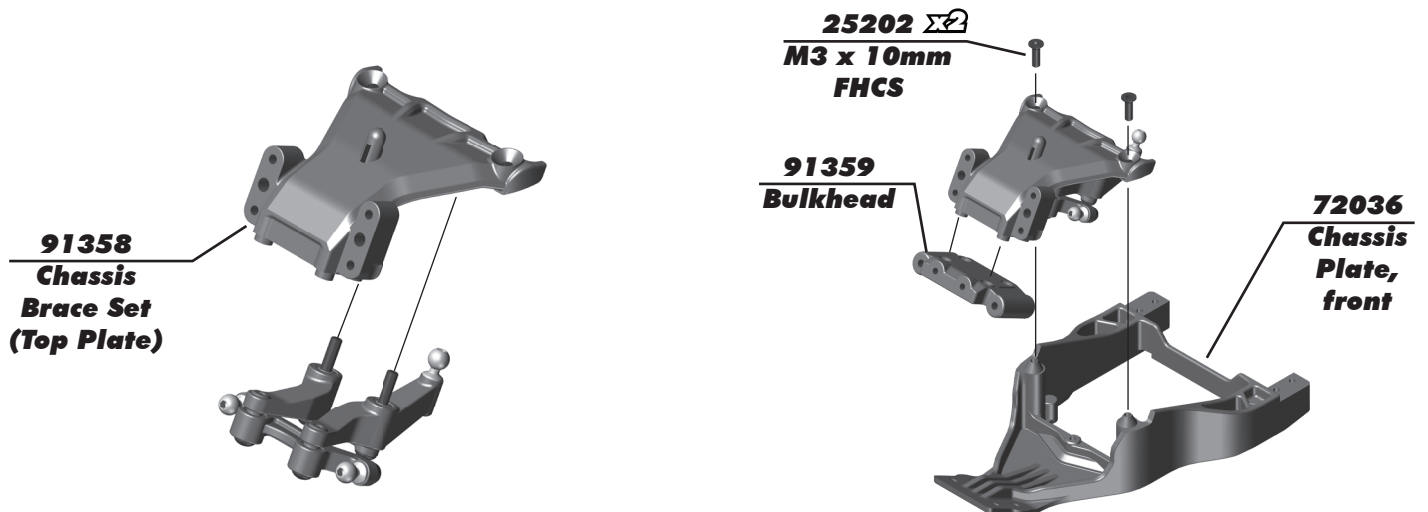

**:: Bag 2 - Step 1**

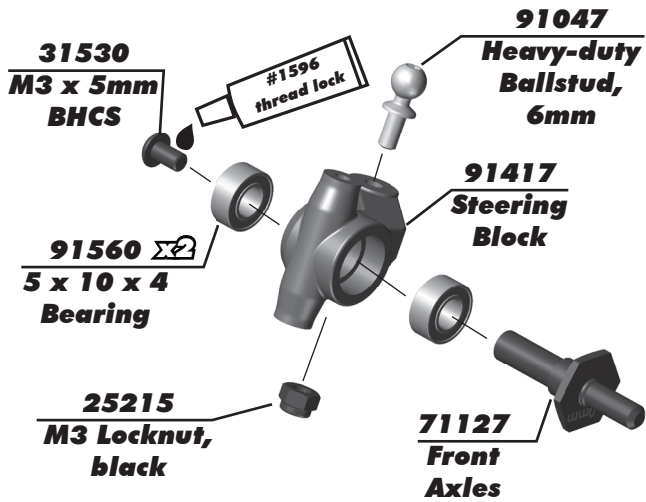

**Build 2 (1 left, 1 right)**

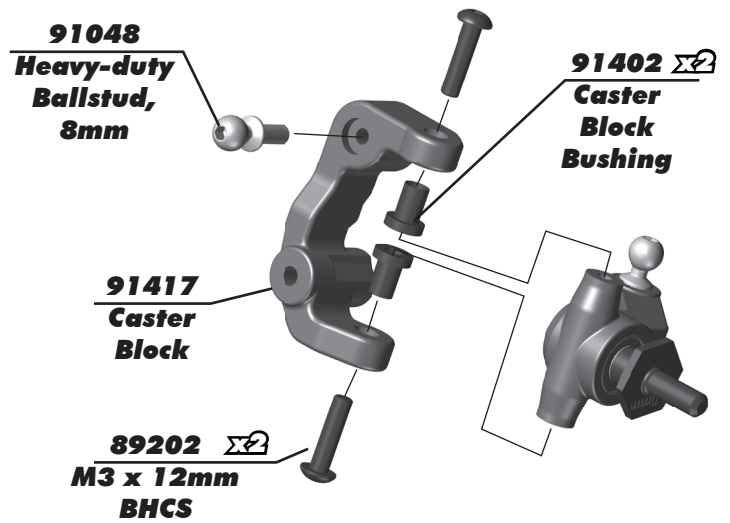

**:: Bag 3 - Step 1**

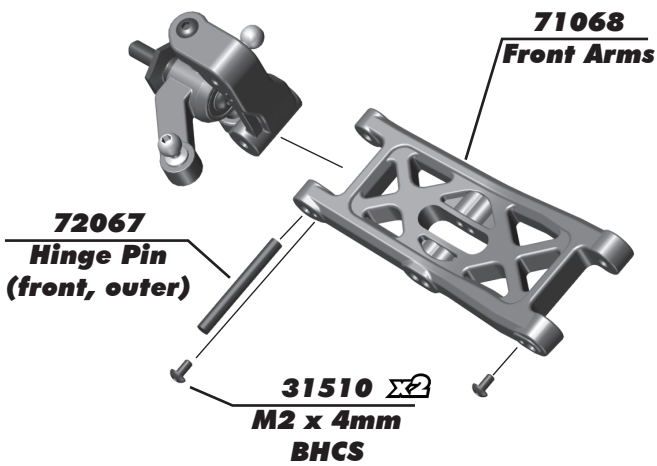

**Build 2 (1 left, 1 right)**

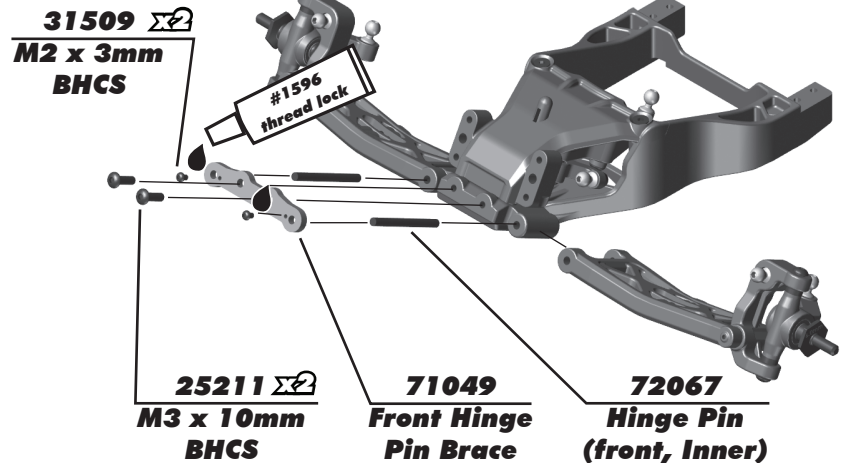

**:: Bag 3 - Step 2**

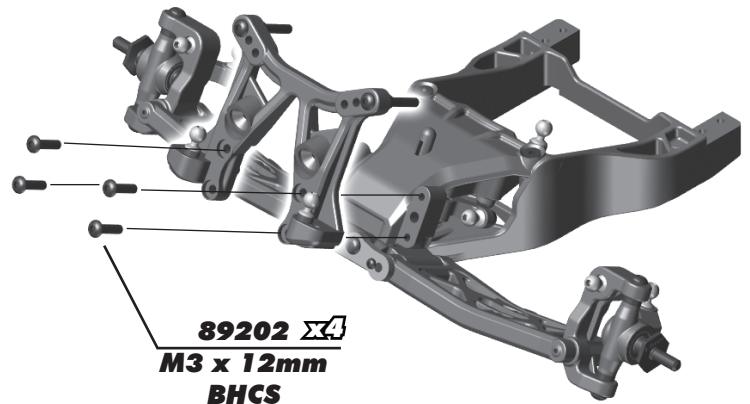
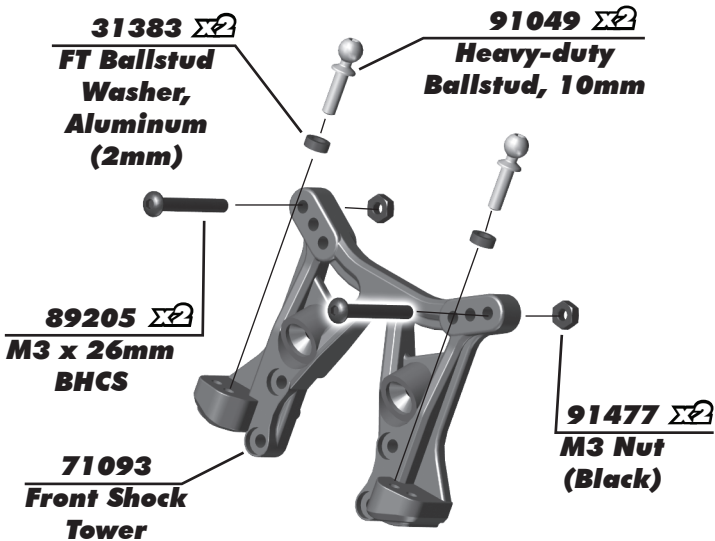

**:: Bag 3 - Step 3**

**71094**  $\Sigma 2$   
Front Bumper  
Brace

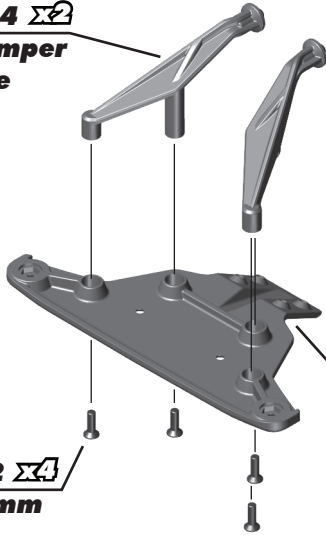

**71094**  
Front  
Bumper

**25202**  $\Sigma 4$   
M3 x 10mm  
FHCS

**71032**  $\Sigma 2$   
M2.5 x 14mm  
SHCS

**31522**  $\Sigma 2$   
M2.5 x 10mm  
BHCS

**72056**  $\Sigma 2$   
Front Body  
Post

**25202**  $\Sigma 2$   
M3 x 10mm  
FHCS

**72056**  $\Sigma 2$   
Body  
Pivots

**72056**  $\Sigma 2$   
Body  
Post  
Sleeve

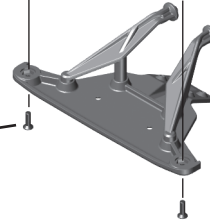

**:: Bag 3 - Step 4**

**25203**  $\Sigma 2$   
M3 x 12mm  
FHCS

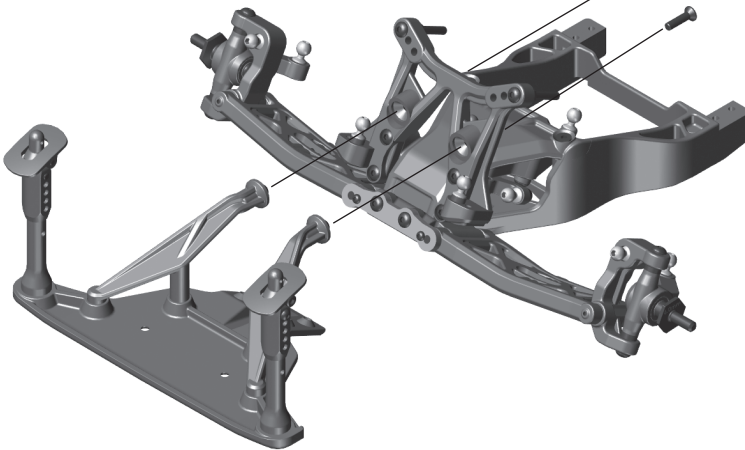

**89210**  $\Sigma 4$   
M3 x 20mm  
FHCS

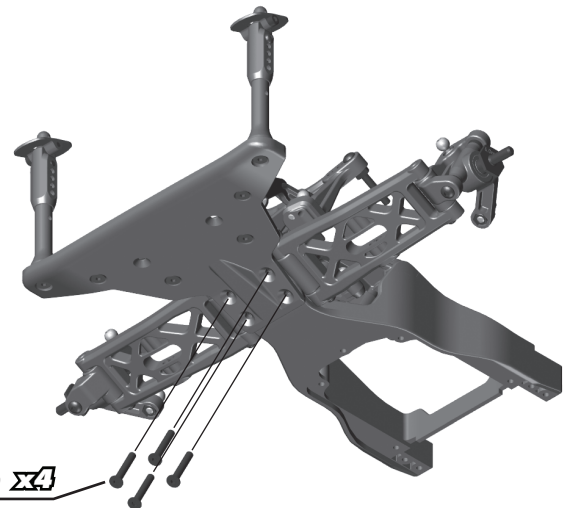

**:: Bag 4 - Step 1**

**72078**  
DR10M Arm  
Mount C

**92014**  $\Sigma 2$   
Arm Mount  
Inserts

**25201**  $\Sigma 2$   
M3 x 8mm  
FHCS

**2.5°**  
Kit STD.

**72081**  
DR10M  
Chassis

**92014**  $\Sigma 2$   
Arm Mount  
Inserts

**72079**  
DR10M Arm  
Mount D

**72067**  $\Sigma 2$   
Hinge Pin,  
Rear Inner

**72040**  $\Sigma 2$   
DR10M Rear  
Suspension Arms

**25201**  
M3 x 8mm  
FHCS

**-0.5°**  
Kit STD.

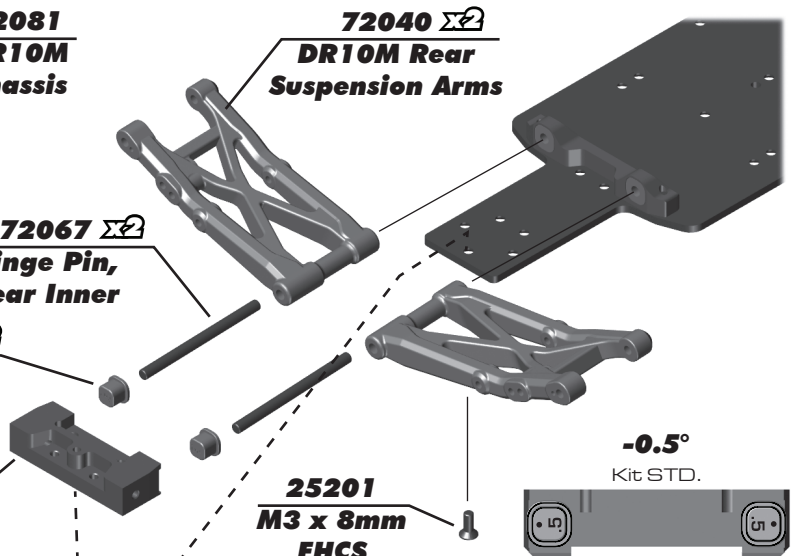
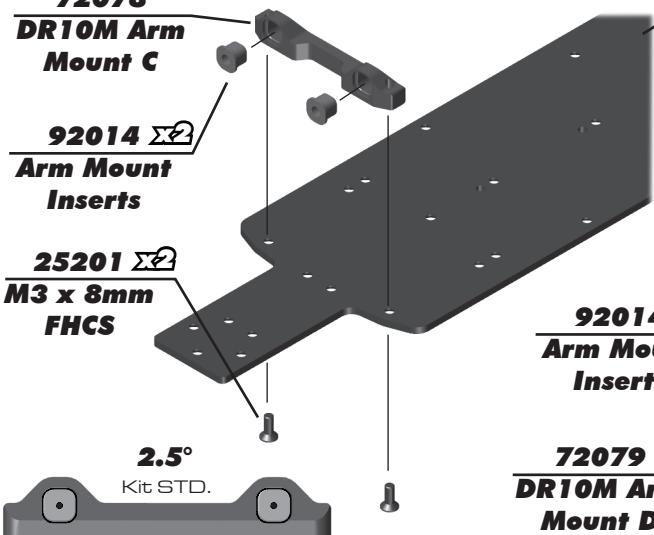

**:: Bag 5 - Step 1**

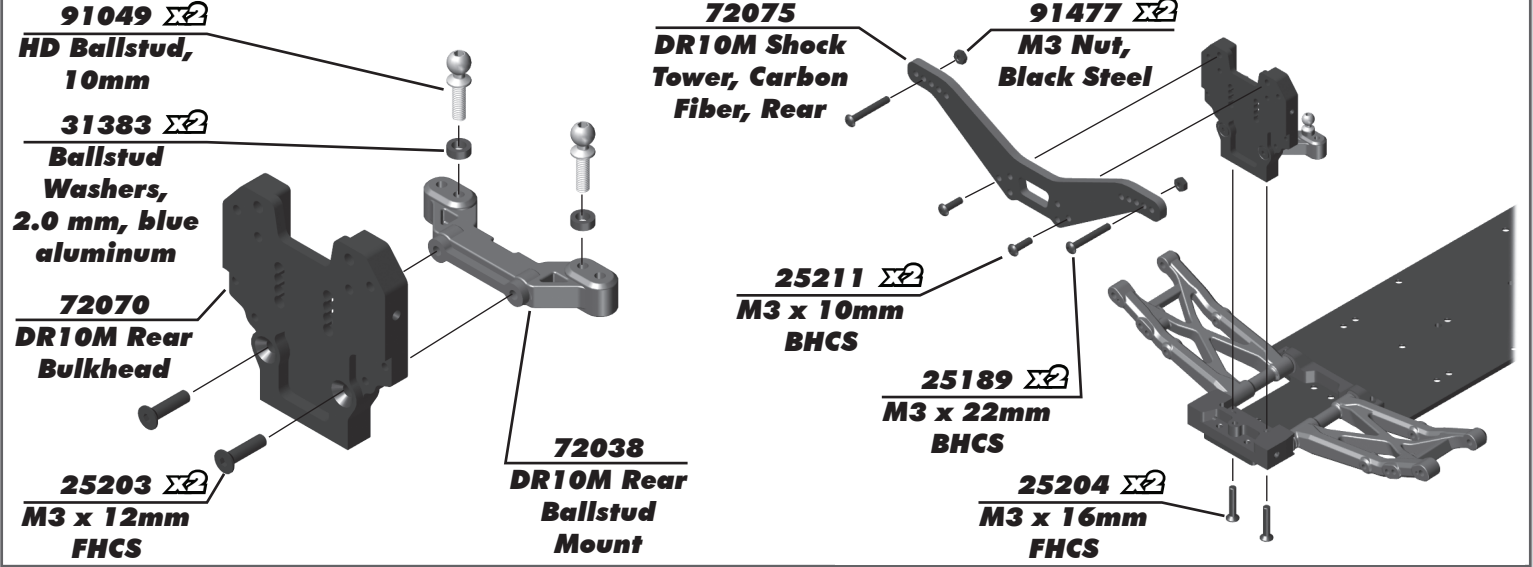

**:: Bag 5 - Step 2**

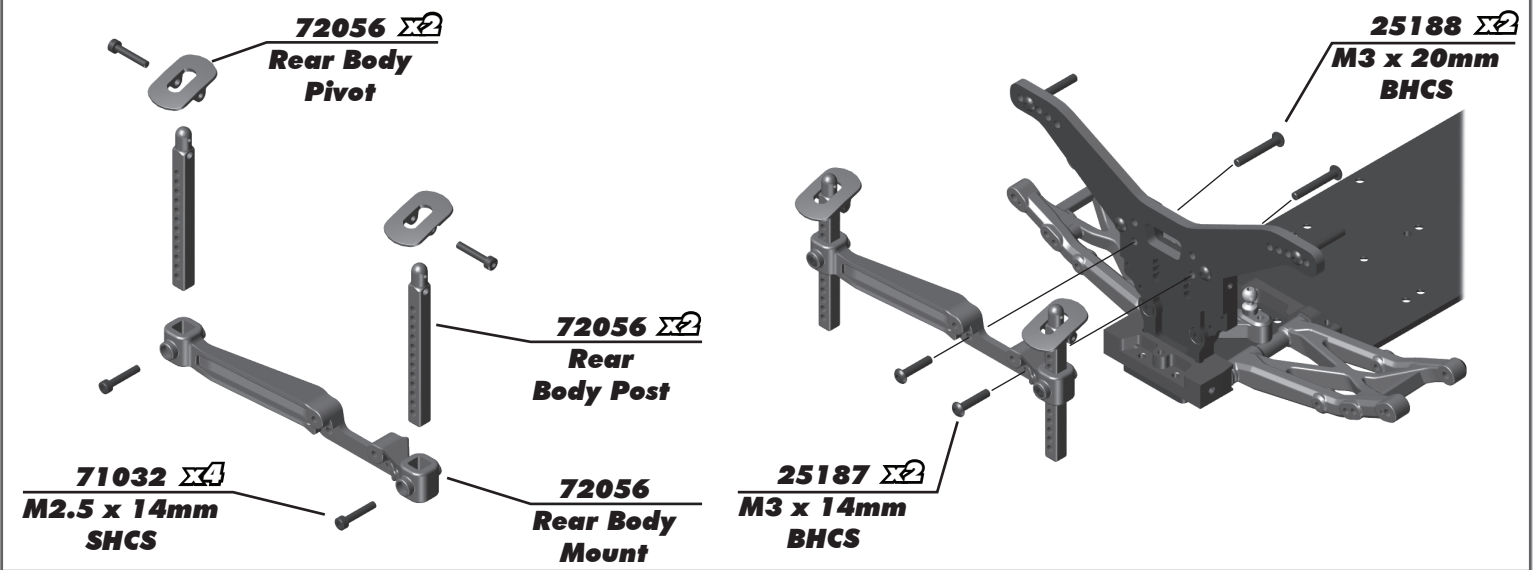

**:: Bag 6 - Step 1**

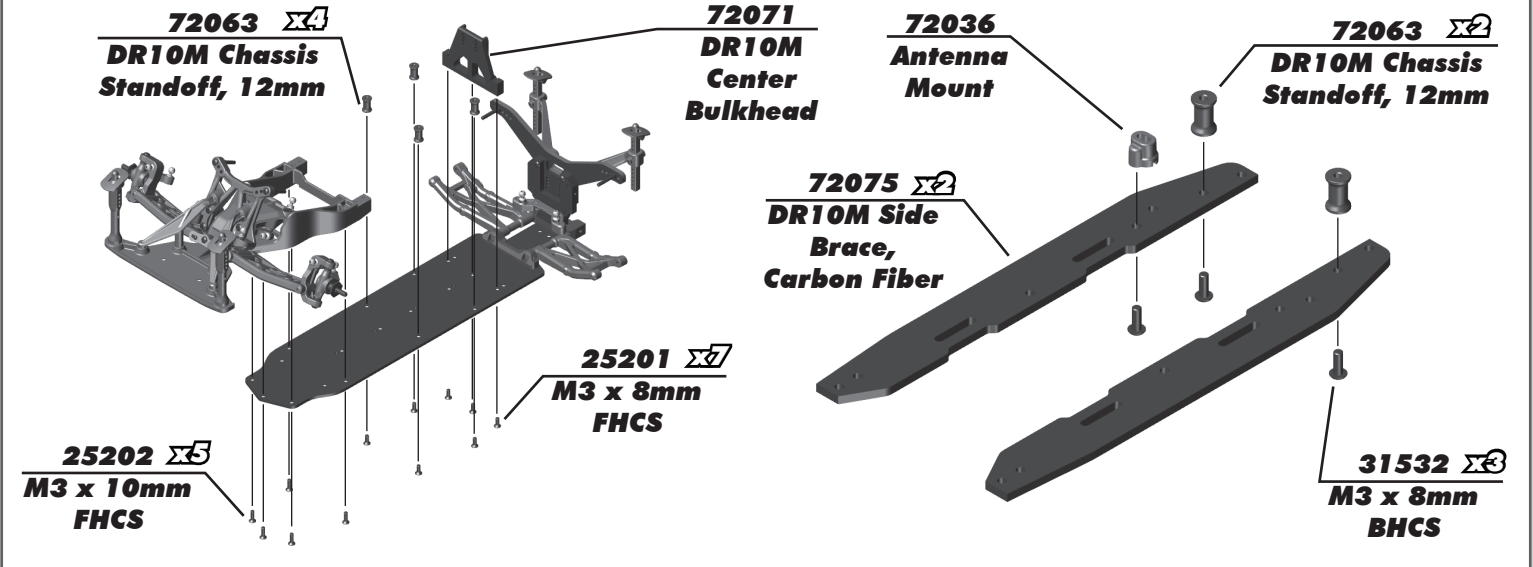



**:: Bag 6 - Step 2**

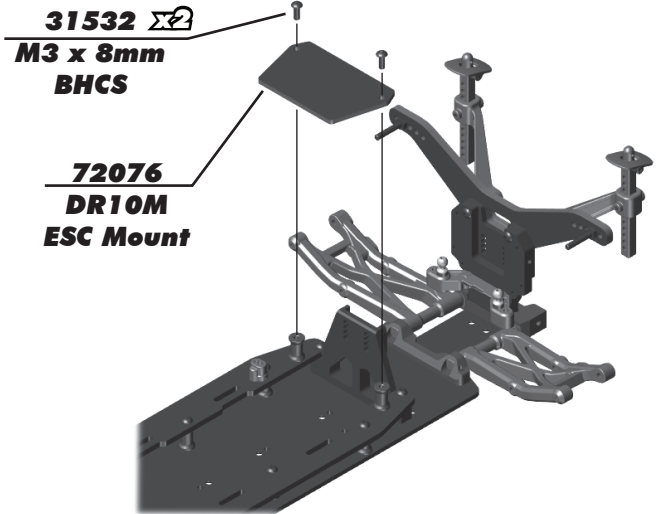
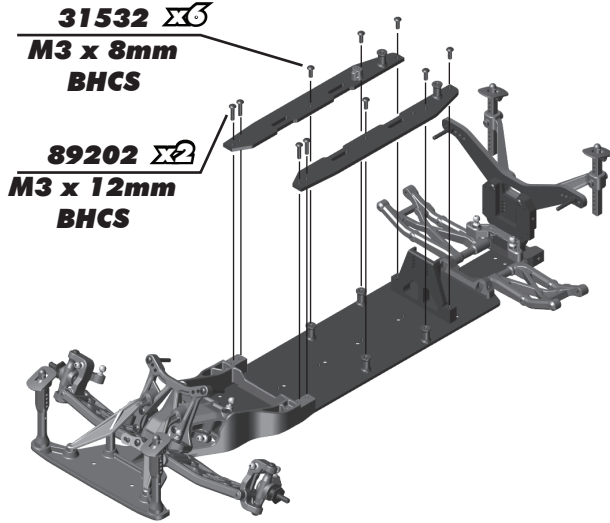

**:: Bag 7 - Step 1**

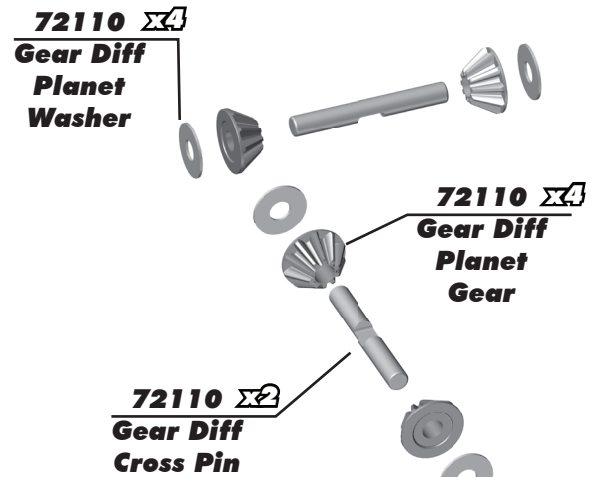
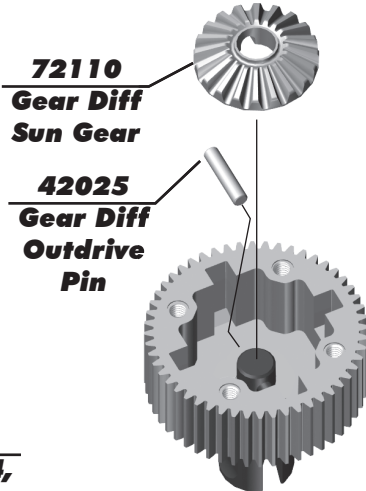
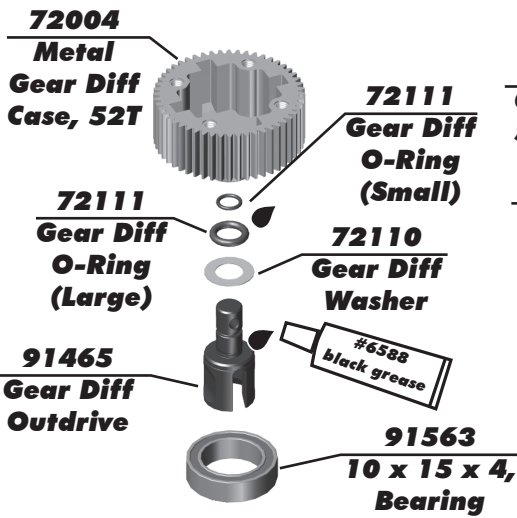

**:: Bag 7 - Step 2**

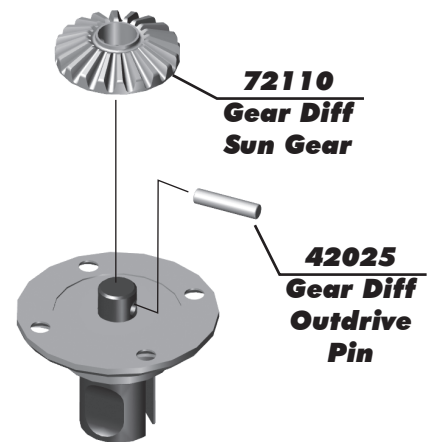
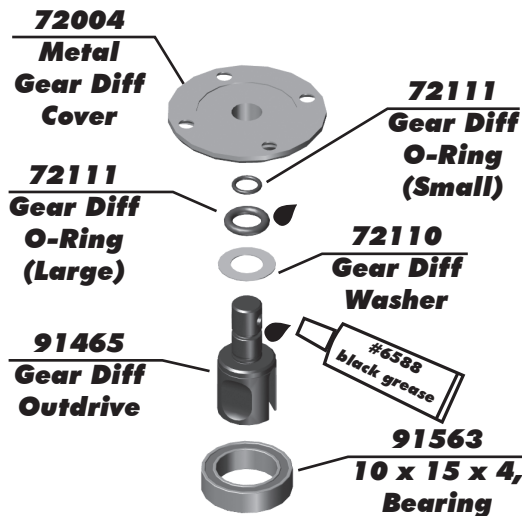
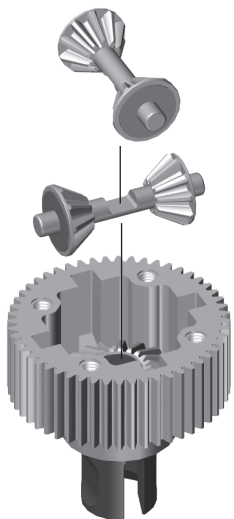

**:: Bag 7 - Step 3**

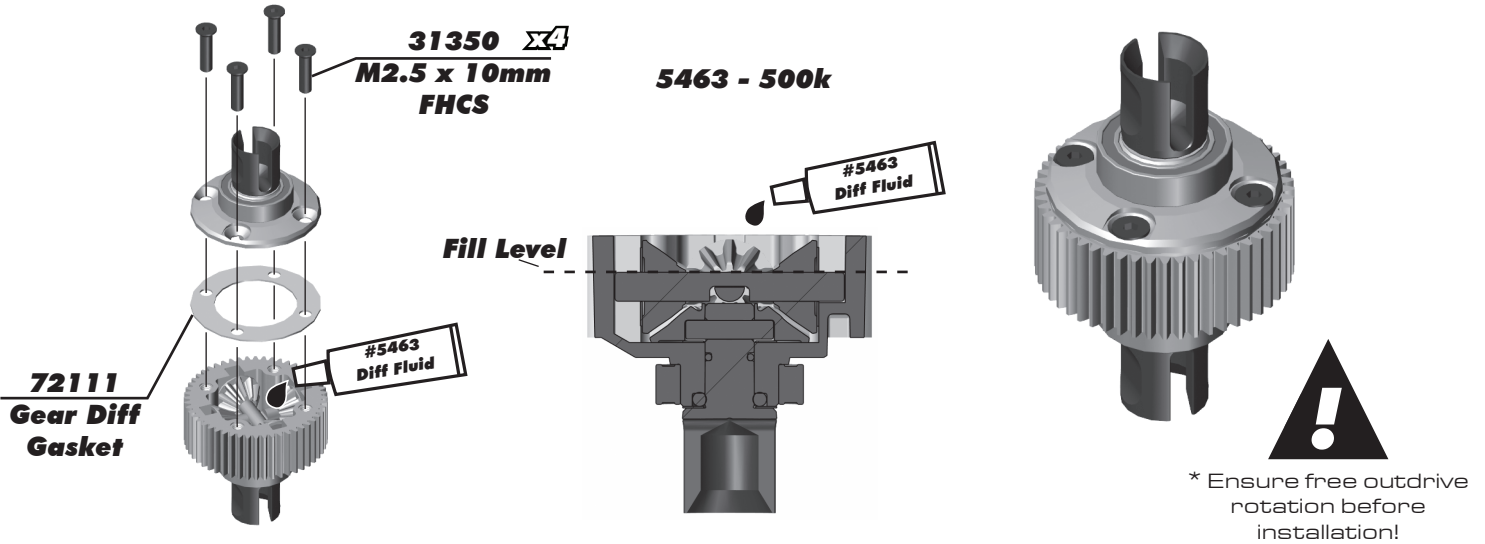

**:: Bag 8 - Step 1**

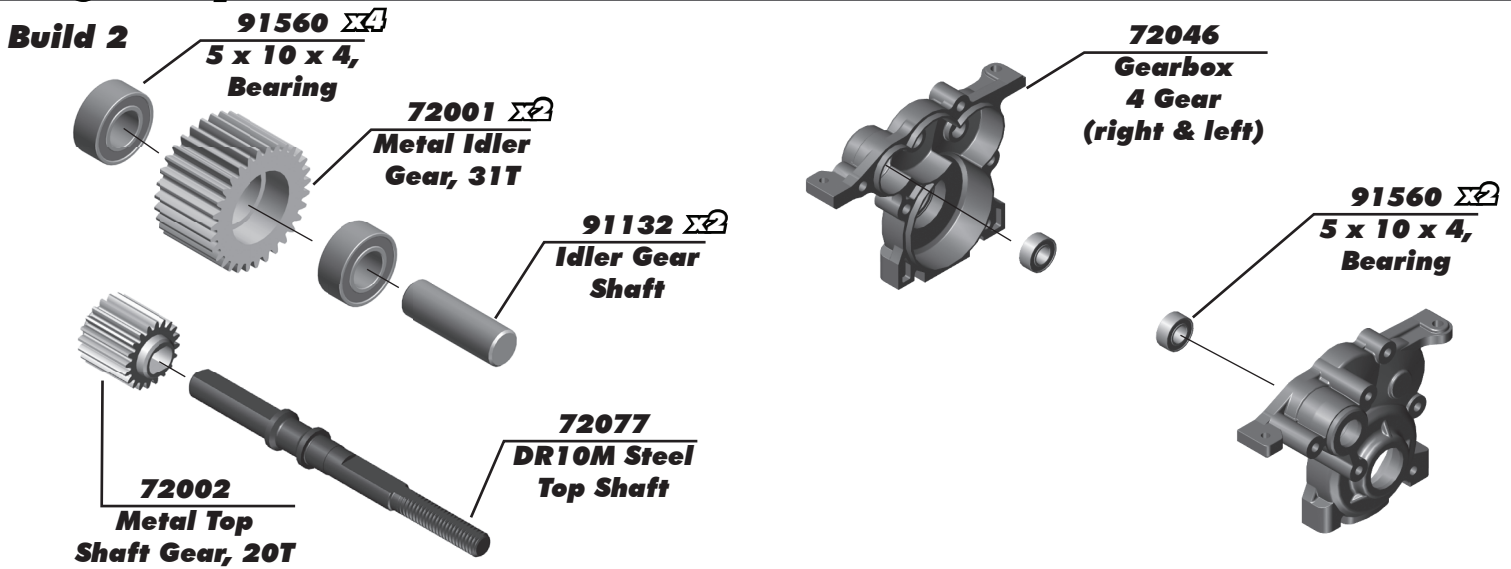

**:: Bag 8 - Step 2**

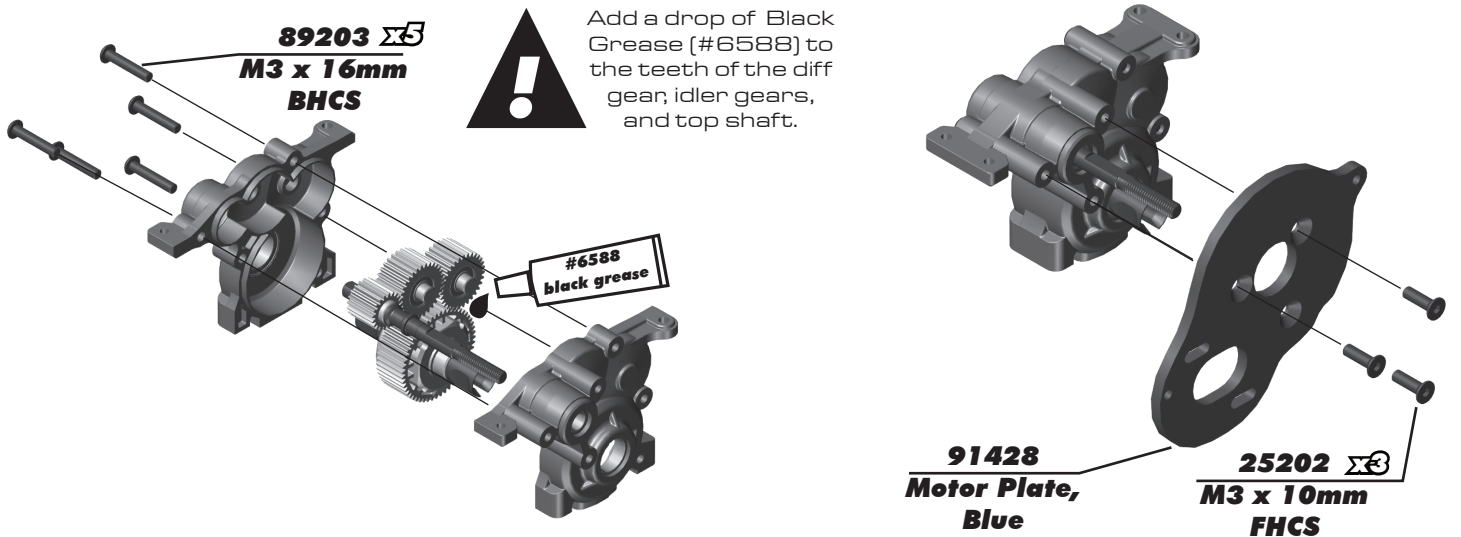

**:: Bag 8 - Step 3**

**Inner**   **Outer**

**72108**  
**DR10M**  
**Slipper Hub, Inner**

**92295**  
**Octalock Spur Gear, 78T 48P**

**92285**  $\Sigma 2$   
**FT Octalock LCF Slipper Pad, 11mm**

**72108**  
**DR10M**  
**Slipper Hub, Outer**

**92276**  
**Slipper Spring**

**91423**  
**Slipper Spring Adapter**

**91738**  
**M4 Locknut, with flange and knurl**

Note the difference between the inner and outer slipper hubs when installing.

**72036**  
**DR10M**  
**Gearbox Mount**

**72073**  
**DR10M Center Brace Mount**

**31532**  $\Sigma 2$   
**M3 x 8mm BHCS**

**25211**  $\Sigma 2$   
**M3 x 10mm BHCS**

**:: Bag 8 - Step 4**

**72036**  
**DR10M**  
**Gearbox Spacer**

**31532**  $\Sigma 4$   
**M3 x 8mm BHCS**

**72036**  
**DR10M**  
**Gearbox Brace**

**25211**  $\Sigma 2$   
**M3 x 10mm BHCS**

**89209**  $\Sigma 4$   
**M3 x 18mm FHCS**

The Locknut should be 6mm in with the top shaft when installed.

**:: Bag 8 - Optional Gearbox Settings**

**3mm Spacer (zero)**  
**Use #25203**  
**12mm FHCS**

**3mm Spacer x2 (6mm)**  
**Use #89208**  
**14mm FHCS**

**3mm Spacer x3 (9mm) - Kit Setting**  
**Use #89209**  
**18mm FHCS**

**3mm Spacer x4 (12mm)**  
**Use #89210**  
**20mm FHCS**

**:: Bag 9 - Step 1**

**91438 CVA Coupler**

**#6588 black grease**

**72096 CVA Bone, 66mm**

**91438 CVA Pin**

**71019 HD CVA Axle**

**91563 10 x 15 x 4 Bearing**

**91418 Rear Hub**

**91562 6 x 13 x 5 Bearing**

**Build x2 (right and left side)**

**Build x2 (right and left side)**

**:: Bag 9 - Step 2**

**91418 Wheel Hex (rear)**

**91048 Heavy-duty Ballstud, 8mm**

**91436 CVA Wheel Hex Pin**

**31510 M2 x 4mm BHCS**

**72067 Hinge Pin (rear, outer)**

**Build x2 (right and left side)**

**:: Bag 10 - Step 1**

**91469 Ball Cup**

**91723 Turnbuckles, 3x48mm**

**91469 Ball Cup**

**Front Camber Turnbuckle 23.00mm**

**Build x2 (right and left side)**

**Racers Tip:**  
Use black grease (#6588) on the threads of the turnbuckles for easier ball cup installation!

**!**  
Orient the notch to the left throughout the car. It indicates which end has the left hand threads!



**:: Bag 10 - Step 2**

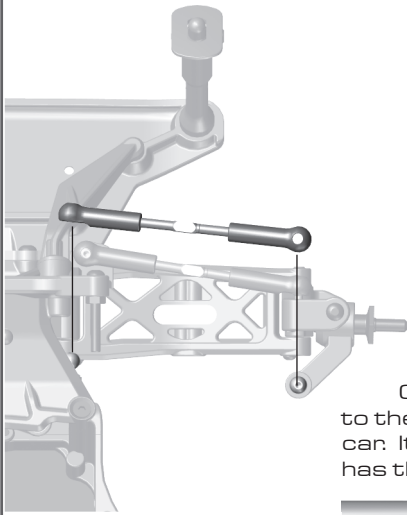

Racers Tip:  
Use black grease (#6588) on the threads of the turnbuckles for easier ball cup installation!



Orient the notch to the left throughout the car. It indicates which end has the left hand threads!



**91469**  
Ball Cup

**91723**  
Turnbuckles,  
3x48mm

**91469**  
Ball Cup



**Steering Turnbuckle**  
**28.00mm**

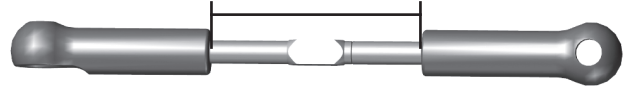

**Build x2 (right and left side)**

**:: Bag 10 - Step 3**

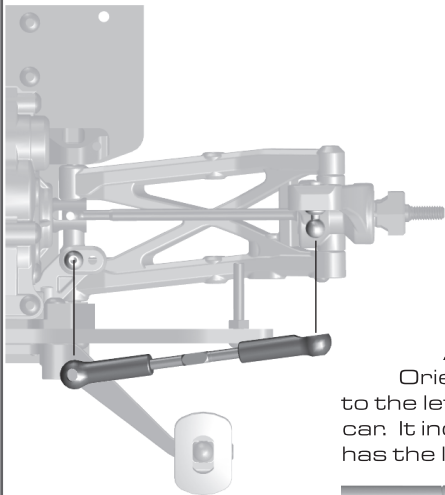

Racers Tip:  
Use black grease (#6588) on the threads of the turnbuckles for easier ball cup installation!



Orient the notch to the left throughout the car. It indicates which end has the left hand threads!



**91469**  
Ball Cup

**91723**  
Turnbuckles,  
3x48mm

**91469**  
Ball Cup



**Rear Camber Turnbuckle**  
**25.00mm**



**Build x2 (right and left side)**

**:: Bag 11 - Step 1**

**91444**  
12mm  
Shock Piston

**6299**  
1/8 E-Clip

**6299**  
1/8 E-Clip

**91488**  
3 x 21mm  
Shock Shaft  
(front, rear)



Racers Tip:

Use a marker over the numbers on the pistons to make them easily visible!

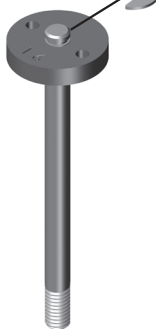

**91480**  
Shock Body  
12 x 23mm  
(front, rear)

**!**  
Lightly rub shock oil on the o-ring before installation!

**31327**  
Shock  
Bottom Cap  
O-Ring

**91444**  
Shock  
Internals

**#1105**  
green slime

**91454**  
Shock  
Bottom Cap

**5407** **O-Ring**



Racers Tip:

Use green slime on all o-rings. Not included!



**:: Bag 11 - Step 2**



Racers Tip:

Coating the o-rings with green slime (#1105) helps seal & reduce o-ring swell! **Green slime not included in kit!**

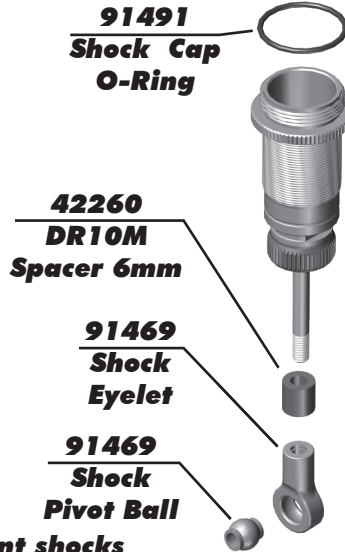

**Build x2 front shocks**

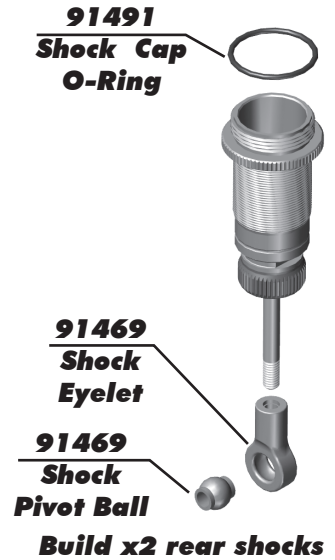

**Build x2 rear shocks**

**:: Bag 11 - Step 3**

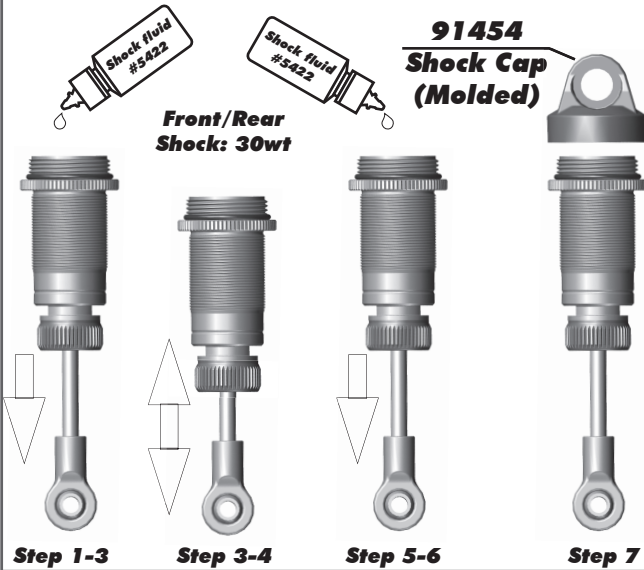

**Shock Bleeding Steps:**

1. Pull shock shaft down.
2. Fill shock body 3/4 full with silicone fluid.
3. Slowly move the shock shaft up and down to remove air from under piston.
4. Wait for bubbles to come to surface.
5. Fill shock body to top with silicone fluid.
6. Place a drop of oil in the cap and on cap threads.
7. Install cap and tighten completely.
8. Slowly compress shaft all the way to the top. If there is pressure at the top of the stroke, there is too much oil or air. You must bleed it out.
9. Slowly pull shaft out.
10. Unscrew the cap 3/4 turn and tilt the shock at a slight angle.
11. Slowly compress the shaft to push out excess oil and air. You should see bubbles coming out from under the cap.
12. With the shaft compressed, tighten the cap and re-check for pressure at the top of the stroke. If there is still pressure, repeat steps 9 thru 11.

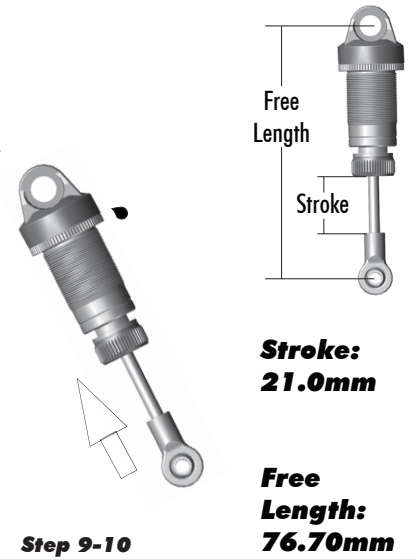

Free Length

Stroke

**Stroke: 21.0mm**

**Free Length: 76.70mm**

**:: Bag 11 - Step 4**

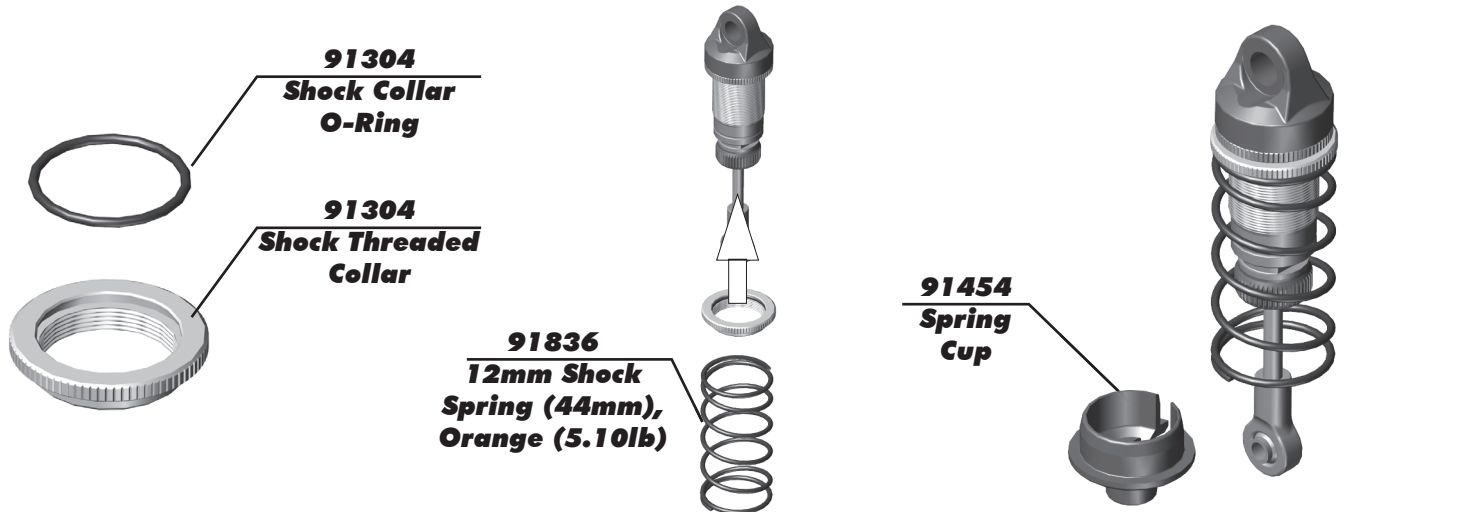

**Build x2 front and x2 rear shocks**

**:: Bag 11 - Step 5**

**!** Use outside hole in front arm!

**91444 Shock Bushing**

**25189 M3 x 22mm BHCS**  
Build x2 (right and left side)

**25612 M3 Locknut, with flange (black)**

**91444 Shock Bushing**

**!** Use outside hole in rear arm!

**25612 M3 Locknut, with flange (black)**

**89202 M3 x 12mm BHCS**  
Build x2 (right and left side)

**:: Bag 12 - Step 1**

**72047 Anti-Roll Bar Ball Cup**

**72064 DR10M Anti-Roll Bar Hardware**

**72047 Rod End**

**31522  $\Sigma 2$  M2.5 x 10mm BHCS**

Build x2 (right and left side)

**:: Bag 12 - Step 2**

**72066 DR10M Anti-Roll Bar (3mm)**

**8691  $\Sigma 4$  M2.5 x 12mm SHCS**

**72047  $\Sigma 2$  Anti-Roll Bar Mounts**

**89219  $\Sigma 4$  M3 x 5mm Set Screw**

**:: Bag 13 - Step 1**

Clean the tire and wheel bead.  
Carefully apply CA glue  
(tire adhesive) to the tire bead  
on both sides. Do one side at a  
time, allow it to dry before  
gluing the other side!  
**CA glue not included!**

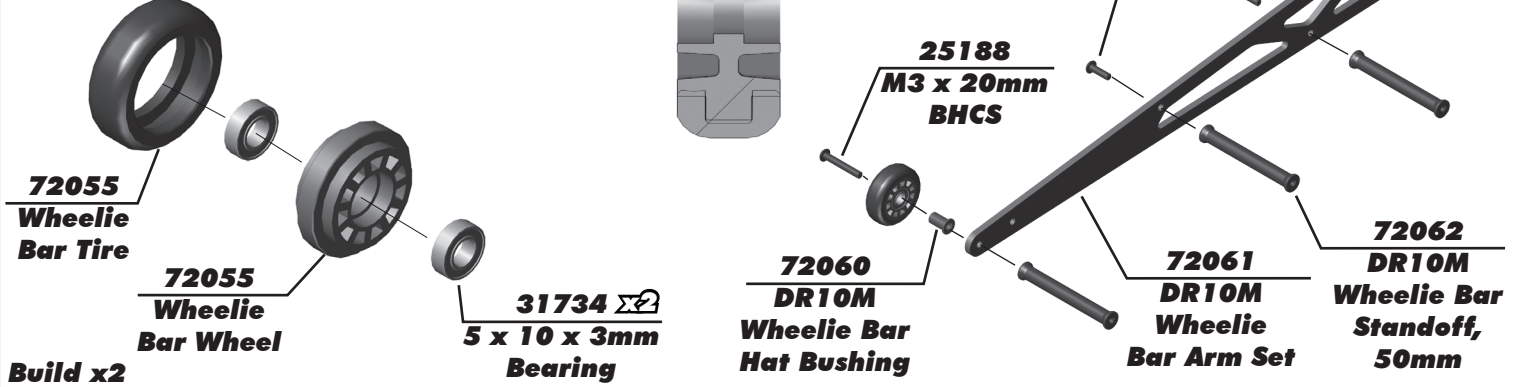

**:: Bag 13 - Step 2**

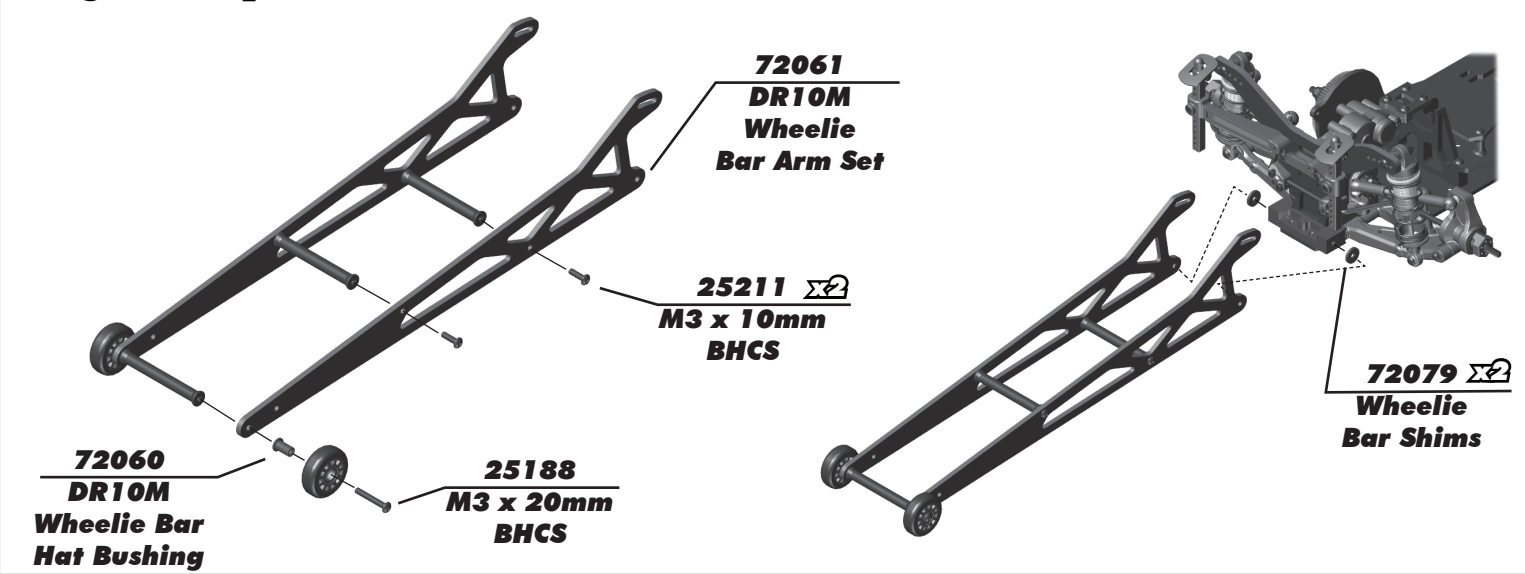

**:: Bag 13 - Step 3**

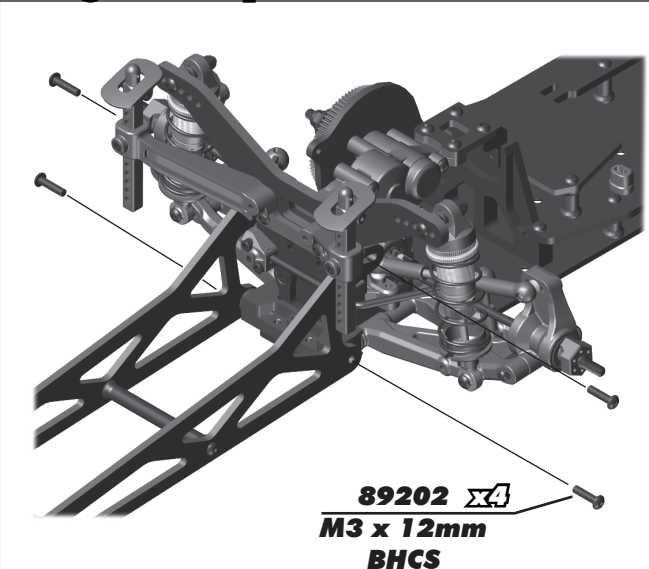

**:: Bag 14 - Step 1**

Align the servo horn 90 degrees.  
Adjust steering trim once vehicle  
is complete.

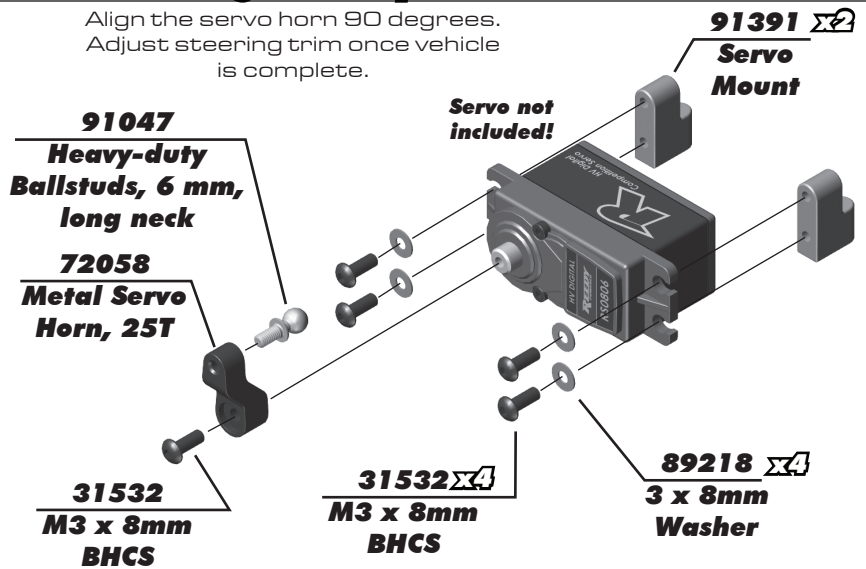



**:: Bag 14 - Step 2**

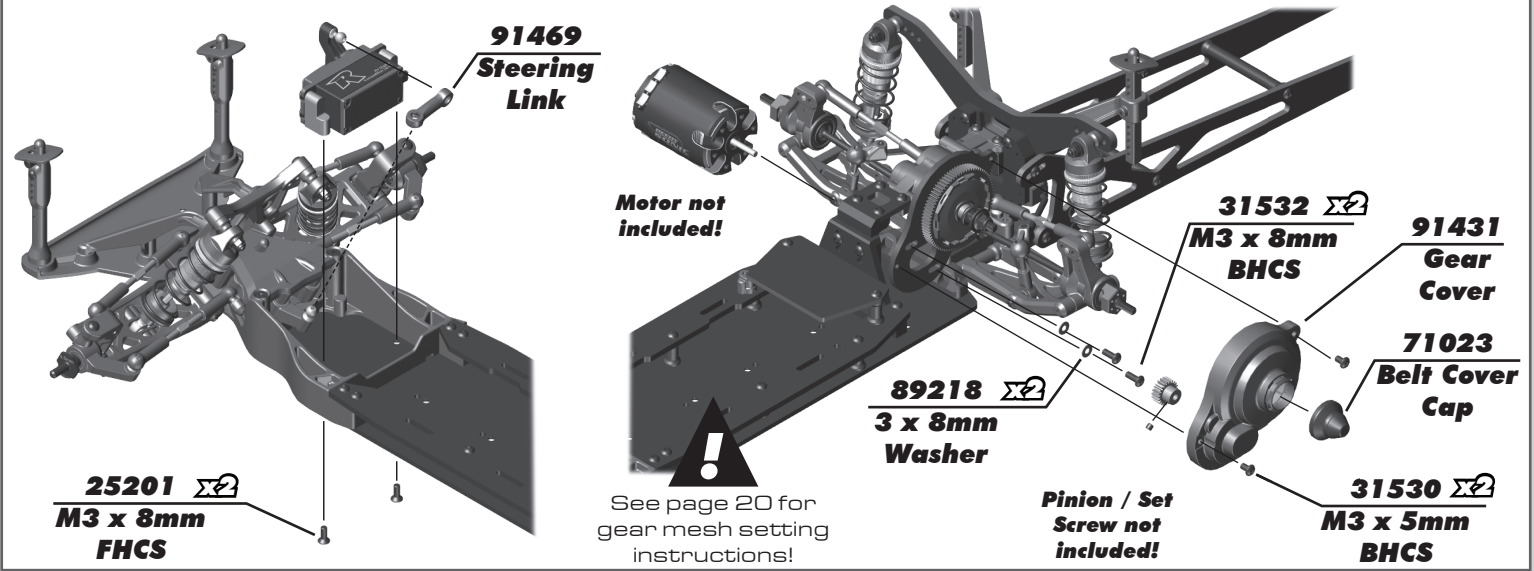

**:: Bag 14 - Step 3**

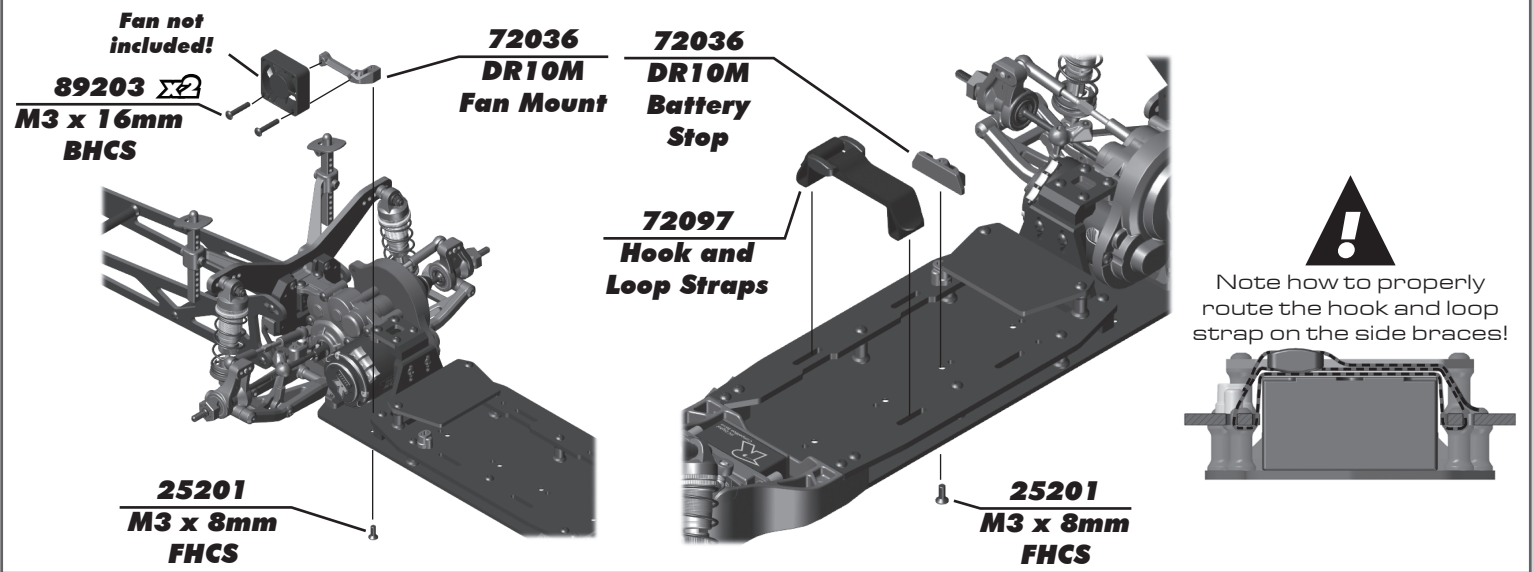

**:: Bag 14 - Step 4**

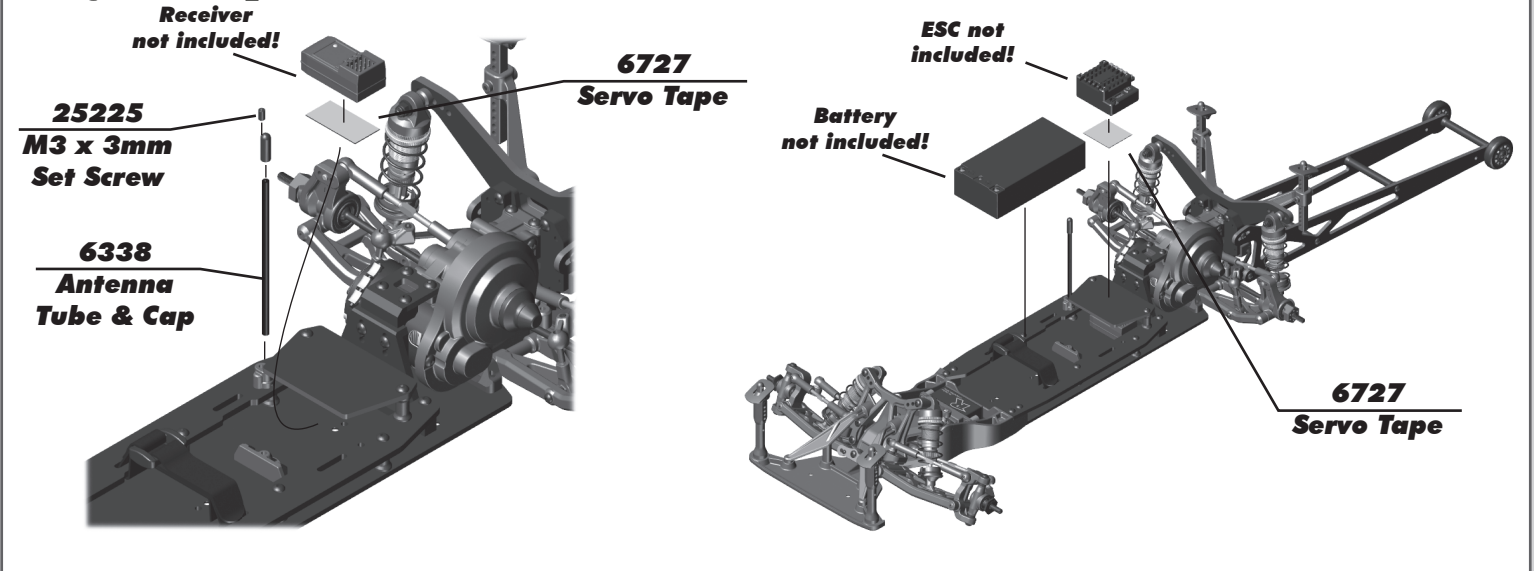

**:: Bag 14 - Step 5**

**Possible Battery Configurations:**

**Shorty Battery**

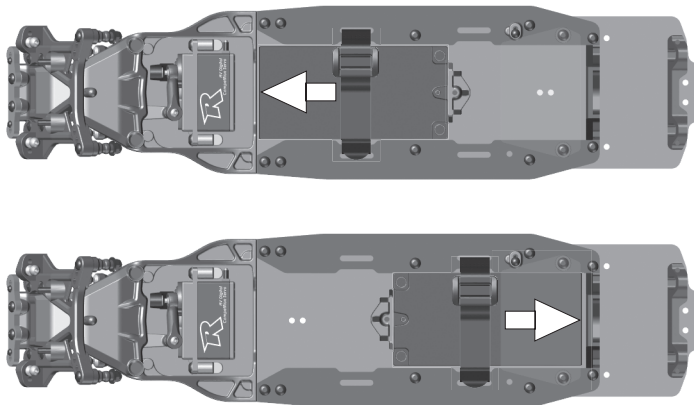

**Standard Battery**

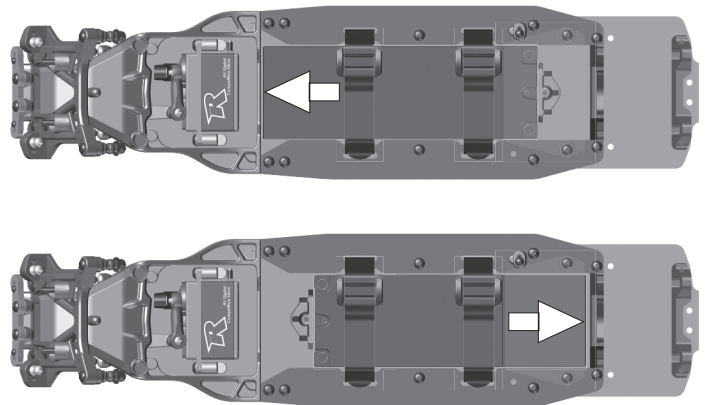

**:: Tires and Body Build - Step 1**

**Wheels and Tires not Included!**

**71078**  
Wheel,  
Rear

**71079**  
Wheel,  
Front

**71073**  
Pre Glued  
Wheel/Tire,  
Front

**Build x2 (front and rear)**

**71072**  
Pre Glued  
Wheel/Tire,  
Rear

**71075**  
DR10 Drag  
Slick Tires,  
Front

**71074**  
DR10 Drag  
Slick Tires,  
Rear



Clean the tire and wheel bead. Carefully apply CA glue (tire adhesive) to the tire bead on both sides. Do one side at a time, allow it to dry before gluing the other side!  
**CA glue not included!**

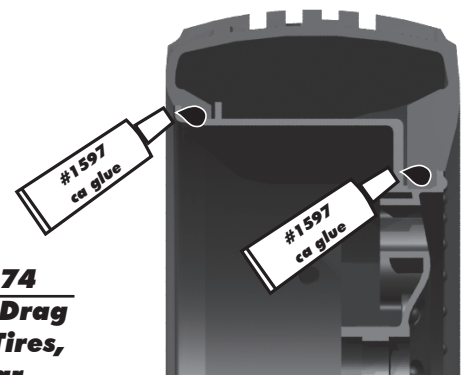

**:: Tires and Body Build - Step 2**

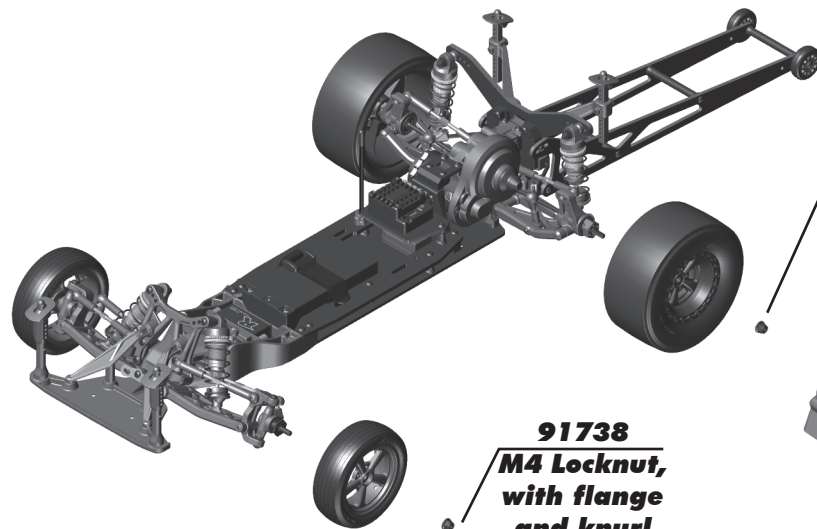

**91738**  
M4 Locknut,  
with flange  
and knurl

**91738**  
M4 Locknut,  
with flange  
and knurl

**Body not Included!**



## :: Tuning Tips

### Painting:

Your Kit comes with a clear polycarbonate body. You will need to prep the body before you can paint it. Wash the INSIDE thoroughly with warm water and liquid detergent (do not use any detergents with scents or added hand lotion ingredients!). Dry the body using a clean, soft, lint-free cloth. Use the supplied window masks to cover the windows from the INSIDE of the body (RC cars get painted on the inside). Using high quality masking tape, apply tape to the inside of the body to create a design. Spray (use either rattle can or airbrush) the paint on the inside of the body (preferably dark colors first, lighter colors last). NOTE: ONLY use paint that is recommended for (polycarbonate) plastics. If you do not, you can destroy the body! After the paint has completely dried (usually after 24 hours), cut the body along the trim lines. Make sure to drill or use a body reamer to make the holes for the antenna if needed! Use hook and loop tape to secure the body to the side rails of the vehicle.

### Tips for Beginners:

Before making any changes to the standard setup, make sure you can get down the track without crashing. Changes to your vehicle will not be beneficial if you can't stay on the track. Your goal is consistent passes. Once you can get down the track consistently, start tuning your vehicle. Make only ONE adjustment at a time, testing it before making another change. If the result of your adjustment is a faster pass, mark the change on the included setup sheet (make additional copies of the sheet before writing on it). If your adjustment results in a slower pass, revert back to the previous setup and try another change. When you are satisfied with your vehicle, fill in the setup sheet thoroughly and file it away. Use this as a guide for future track days or conditions. Periodically check all moving suspension parts. Suspension components must be kept clean and move freely without binding to prevent poor and/or inconsistent handling.

### Rear Arm Mount Pill Insert Setup:

The aluminum rear arm mounts utilize eccentric pill inserts to make fine adjustments to anti-squat, toe, pin heights, and pin width. Adjustments can be made using the supplied inserts (#92014)

#### Standard Position

Use this position as a reference when changing pill locations.

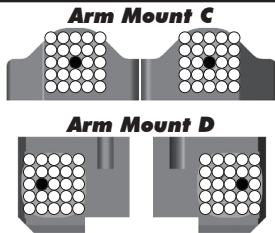

Toe: 0.5°  
Anti-squat: 2.5°  
Roll Center: 0.0°  
Pivot Width: 0.0°

Additional toe settings are achievable using option part #72011 DR10 Aluminum rear hubs.

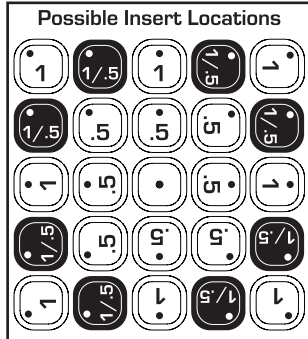

#### Insert Hole Locations

Number indicates degree of change: 0.5°, 1.0°, 0° (center dot)

•.5 Hole 0.5° or 0.35mm from center

•1 Hole 1.0° or 0.7mm from center

#### Toe Angle

More angle = More toe in  
Less angle = Less toe in  
\*Shown in 1° changes

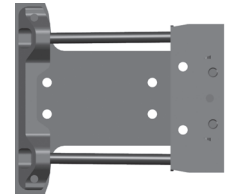

#### C Mount

#### D Mount

		<b>-2.0°</b>
		<b>-1.0°</b>
		<b>-1.5°</b>
		<b>0.0°</b>
		<b>-0.5°</b> Kit STD.

#### Anti-squat Angle

More angle = More anti-squat  
Less angle = Less anti-squat  
\*Shown in 1° changes



#### C Mount

#### D Mount

		<b>3.0°</b>
		<b>2.5°</b> Kit STD.
		<b>2.0°</b>

## :: Tuning Tips (cont.)

### Motor Gearing:

Proper motor gearing will result in maximum performance and run time while reducing the chance of overheating and premature motor failure. The gear ratio chart lists recommended **starting gear ratios** for the most widely used motor types. Gear ratios will vary depending upon motor brand, wind, and electronic speed control. Consult your motor and electronic speed control manufacturers for more information.

Team Associated is not responsible for motor damage due to improper gearing.

#### Gear Ratio Chart (Internal Gear Ratio 2.60:1)

Motor	Pinion	Spur	Final Drive Ratio
13.5 Reedy Sonic Brushless	*29	*75	6.72:1
4.5 Reedy Sonic Brushless	*22	78	9.22:1
4.0 Reedy Sonic Brushless	*21	78	9.66:1
3.5 Reedy Sonic Brushless	*21	*81	10.02:1

**\* Optional spur gear / pinion used**

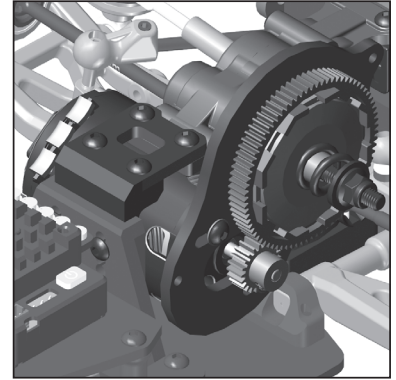

### Set The Gear Mesh:

You should be able to rock the spur gear back and forth in the teeth of the pinion gear without making the pinion gear move. If the spur gear mesh is tight, then loosen the motor mounting screws and move the motor away, then try again. A gear mesh that is too tight or too loose will reduce power and damage the gear teeth.

### Gearbox Height Adjustment:

Adjusting the gearbox height will effectively change rear driveshaft angle. This angle will change how the power is transmitted to the tires. Standard setting is 9mm. Lower setting might be more desirable for low traction conditions.

### Slipper Clutch:

The assembly instructions give you a base setting for your clutch. Turn the nut on the shaft so that there is 6mm of thread showing. At the track, tighten or loosen the nut in 1/8 turn increments until you hear a faint slipping sound for 1-2 feet on takeoffs. Another popular way to set the clutch is to hold both rear tires firmly in place and apply short bursts of throttle. If the clutch is properly set, the front tires should lift slightly up off the surface.

### Ride Height:

Ride height is the distance from the ground to the bottom of the chassis.

The standard front ride height setting is 15mm (Ride Height Gauge). Check the front ride height by cycling the suspension up and down. After the suspension "settles" into place, measure ride height (Ride Height Gauge). Raise or lower the shock collars as necessary.

The rear ride height setting you should use most often is 19mm (Ride Height Gauge). Check the rear ride height by cycling the suspension up and down. After the suspension "settles" into place, measure ride height (Ride Height Gauge). Raise or lower the shock collars as necessary.

### Wheelie Bar Setting:

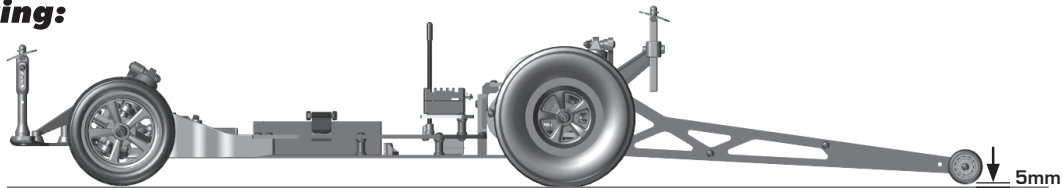

Wheelie bar setting will vary based on track conditions. Once desired ride height is achieved, adjust the distance of the wheelie bar tires from the track surface. Standard setting is 5mm from the ground. For lower traction conditions a higher setting might be desirable.

Wheelie bar tire should never be in contact with the ground with the vehicle stationary.

### Toe Setting:

Front: Standard front toe setting is 0° to -1°

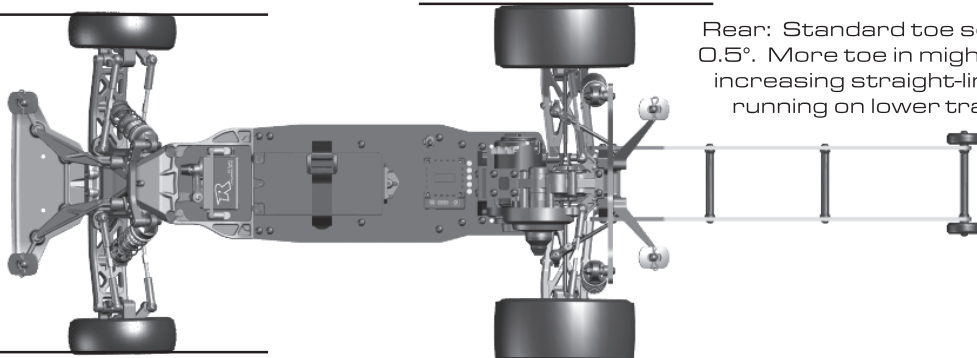

Rear: Standard toe setting is negative 0.5°. More toe in might be desirable for increasing straight-line stability when running on lower traction surface.



### Front Suspension:

Ride Height: \_\_\_\_\_  
 Camber: \_\_\_\_\_  
 Toe: \_\_\_\_\_  
 Arm Type: \_\_\_\_\_  
 Tower Type: \_\_\_\_\_  
 Wheel Hex Width: \_\_\_\_\_  
 Steering Block: \_\_\_\_\_  
 Bulkhead Type: \_\_\_\_\_  
 Kick-Up Angle: \_\_\_\_\_  
 Notes: \_\_\_\_\_  
 \_\_\_\_\_  
 \_\_\_\_\_

Bump Steer Spacing: \_\_\_\_\_

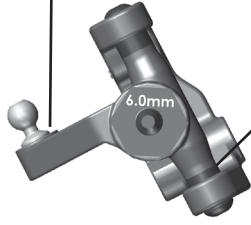

Axle Height:

+3   
 +2   
 +1   
 0

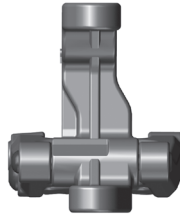

Ball Stud Spacing: \_\_\_\_\_

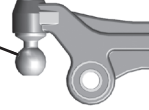

Ball Stud Spacing: \_\_\_\_\_

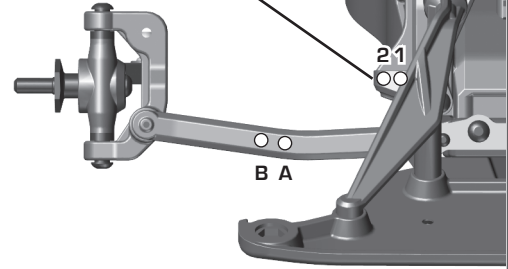

### Rear Suspension:

Ride Height: \_\_\_\_\_  
 Camber: \_\_\_\_\_  
 Toe: \_\_\_\_\_  
 Anti-Roll Bar: Yes  No   
 Arm Type: \_\_\_\_\_  
 Wheel Hex Width: \_\_\_\_\_  
 Notes: \_\_\_\_\_  
 \_\_\_\_\_  
 \_\_\_\_\_

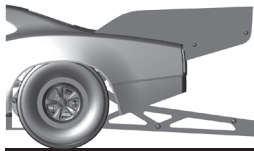
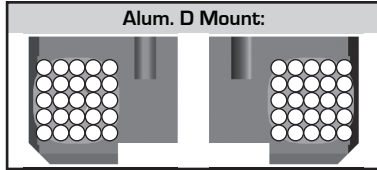
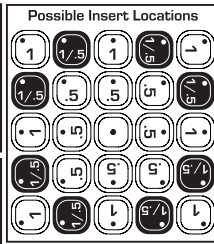
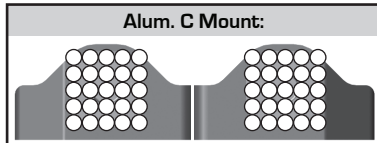

Distance From Ground: \_\_\_\_\_

Ball Stud Spacing: \_\_\_\_\_

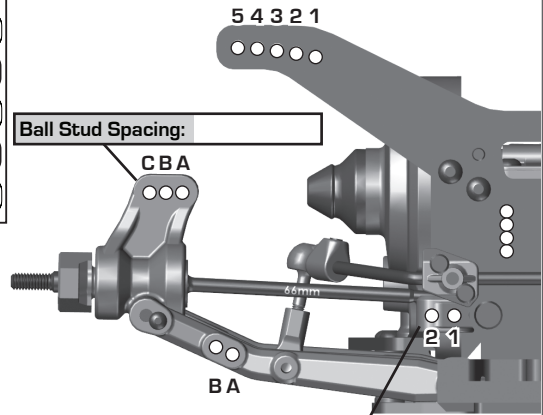

Ball Stud Spacing: \_\_\_\_\_

### Electronics:

Radio: \_\_\_\_\_ Servo: \_\_\_\_\_  
 EPA: Throttle: \_\_\_\_\_ % Brake: \_\_\_\_\_ %  
 ESC: \_\_\_\_\_  
 ESC Settings: \_\_\_\_\_  
 Motor: \_\_\_\_\_  
 Wind: \_\_\_\_\_ Timing: \_\_\_\_\_  
 Pinion: \_\_\_\_\_ Spur: \_\_\_\_\_  
 Battery: \_\_\_\_\_  
 Battery Position: \_\_\_\_\_  
 Battery Weight: \_\_\_\_\_

### Drivetrain:

Differential Setting: \_\_\_\_\_  
 Diff Fluid: \_\_\_\_\_  
 Notes: \_\_\_\_\_  
**Slipper Clutch:**  
 Type: \_\_\_\_\_  
 # of Pads: \_\_\_\_\_  
 Setting: \_\_\_\_\_  
  
 Notes: \_\_\_\_\_

### Shocks:

	Front	Rear
Piston:	_____	_____
Fluid:	_____	_____
Spring:	_____	_____
Limiters:	Int: _____ Ext: _____	Int: _____ Ext: _____
Stroke:	_____	_____
Eyelet Length:	_____	_____
Cup Offset:	_____	_____
Notes:	_____	



### Track Info:

Burnout: Yes  No  Length: \_\_\_\_\_  
 Burnout Surface: \_\_\_\_\_  
 Surface: Asphalt  Concrete  Prep  No-Prep   
 Traction: Low  Medium  High  Very High   
 Temperature: Ambient: \_\_\_\_\_ Track: \_\_\_\_\_  
 Tire Warmers: Yes  No  Time: \_\_\_\_\_ Temp: \_\_\_\_\_  
 Notes: \_\_\_\_\_  
 \_\_\_\_\_

### Tires:

Front Tires: \_\_\_\_\_  
 Front Compound: \_\_\_\_\_  
 Front Insert: \_\_\_\_\_  
 Rear Tires: \_\_\_\_\_  
 Rear Compound: \_\_\_\_\_  
 Rear Insert: \_\_\_\_\_  
 Wheel (F/R): \_\_\_\_\_  
 Notes: \_\_\_\_\_

### Body, Weight:

Body: \_\_\_\_\_  
 Body Notes: \_\_\_\_\_  
 Chassis Weights: \_\_\_\_\_  
 Chassis Notes: \_\_\_\_\_  
 Vehicle Weight: Front: \_\_\_\_\_ Rear: \_\_\_\_\_  
 Total Vehicle Weight: \_\_\_\_\_  
 Notes: \_\_\_\_\_

# FIND IT ON ASSOCIATEDELECTRICS.COM

## CARS & TRUCKS



### Vehicle Spare Parts

GO TO:

[AssociatedElectrics.com](#) →  
[Team Associated tab](#) →  
[Cars & Trucks](#) →  
[Scroll to your vehicle](#) →  
[Parts & Accessories link](#)

## SETUP SHEETS & MANUALS



### Setups and Manuals

GO TO:

[AssociatedElectrics.com](#) →  
[Team Associated tab](#) →  
[Manuals & Setups](#) →  
[Scroll to your vehicle](#)

## A-TEAM APPS



### Tuning Guides & Tips

GO TO:

[AssociatedElectrics.com](#) →  
[Support](#) →  
[A-Team Apps](#)



***Associated Electrics, Inc.***

***21062 Bake Parkway Lake Forest, CA 92630 USA***

***call: (949) 544-7500 - fax: (949) 544-7501***

***Check out the following web sites for all of our kits, current products,  
new releases, setup help, tips, and racing info!***

***[www.AssociatedElectrics.com](http://www.AssociatedElectrics.com)***

## FOLLOW US ON SOCIAL MEDIA



**TeamAssociated  
ReedyPower  
ElementRC**



**@TeamAssociatedRC  
@ReedyPower  
@Element\_RC**



**@Team\_Associated  
@ReedyPower**